

**BATTERY CHARGE SYSTEM**

Refer to text on page 1, Sect. 60, Mods. 55-66/60-66/70-66/80-66

**MARELLI OR BOSCH STARTER MOTORS**

See page 2, Sect. 60, Mods. 55-66/60-66

**BATTERY**

Voltage .....	12 V
Nominal capacity (20 h discharge rate) .....	88 Ah standard or dry charge. Alternatively 90 Ah, permanent sealed.

**FUSES**

Six 8 Amp and two 16 Amp fuses, housed in box.		
Fuses	PROTECTED CIRCUITS	Amp
1	Engine shut-off solenoid.	8
2	Turn signal and stop lights (tractor and trailer) with indicators, water temperature gauge, fuel gauge, air cleaner restriction indicator, battery charge indicator, low engine oil pressure indicator, parking brake indicator and sending unit, horn.	8
3	Front R.H. parking light, rear L.H. parking light, license plate light, trailer L.H. parking light, parking light indicator, cab work lights.	8
4	Front L.H. parking light, rear R.H. parking light, trailer R.H. parking light, rear work light, instrument panel light.	8
5	Low beams.	8
6	High beams and indicator.	8
7	Hazard warning indicator and flasher single-pole power point.	16
8	Thermostarter or Start-Pilot.	16

**STARTER SWITCH** - Refer to Table on page 2, Sect. 60, Mods. 55-66/60-66/70-66/80-66 which applies.**LIGHTING SWITCH** - Refer to Table on page 14, Sect. 60, Mods. 466/566/666/766.**TRACTOR/TRAILER TURN SIGNAL SWITCH** - Refer to Table on page 3, Sect. 60, Mods. 55-66/60-66/70-66/80-66.**INSTRUMENT PANEL** - Refer to illustration and text on page 3, Sect. 60, Mods. 55-66/60-66/70-66/80-66.

## ELECTRICAL SYSTEM: Specifications and Data



### Control Board.

A. Hazard warning light switch with visual indicator - B. Turn signal lights switch - C. Fuse box - D. Single-pole power point - E. Starter switch - F. Lighting switch and horn button



Neutral



Parking lights



Headlamp low beams



Headlamp high beams



Horn: press in

G. Thermostarter or Start-Pilot button.

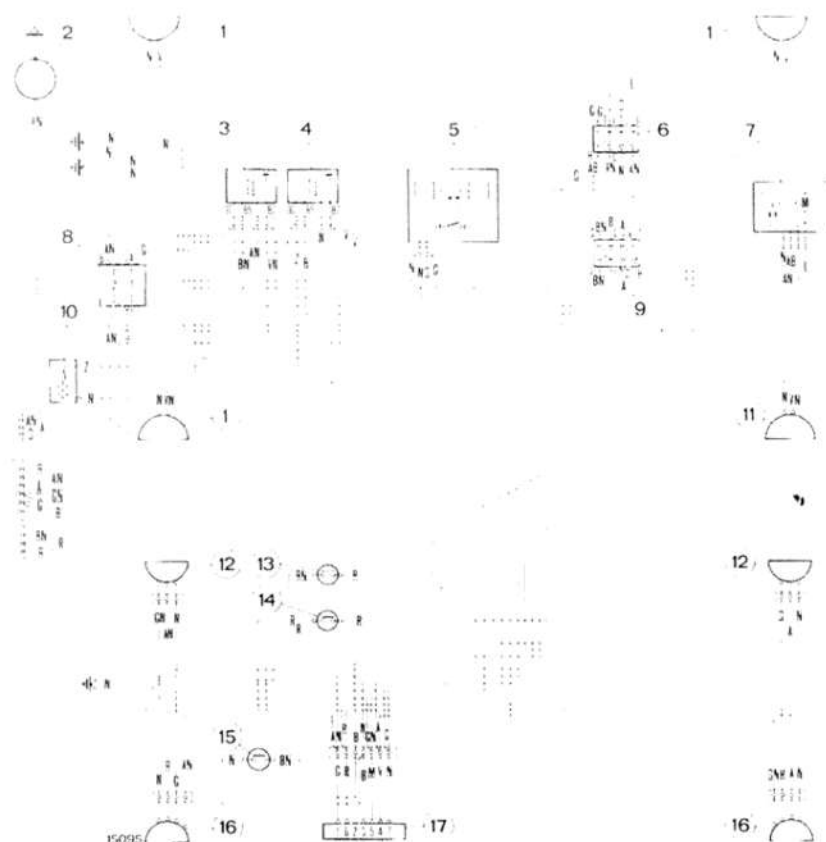

### WIRING DIAGRAM FOR TRACTORS WITH CAB

1. Auxiliary work lights.
2. Washer electro-pump.
3. Rear work lights relay switch.
4. Headlamps relay switch.
5. Fan-heater unit.
6. Wiper/washer switch.
7. Wiper motor.
8. Fuse box.
9. Auxiliary work lights switch.
10. Cab light.
11. Rear work light.
12. Front parking and turn signal switch.
13. Starter inhibition switch.
14. Stop lights switch.
15. Hand (parking) brake indicator.
16. Rear parking, turn signal and stop lights.
17. Seven-pole power point.

**WIRING DIAGRAM  
TRACTOR WITH ACCESSORIES**

*Note* - Detail shows installation of start-pilot device which cannot be fitted together with thermostarter

- ★ To starter connection 50
- To starter switch connection 50

1. Headlamps, high/assymmetric low beams
2. Battery
3. Alternator
4. Low engine oil pressure sending unit
5. Water temperature gauge sending unit
6. Fuel gauge sending unit
7. Horn
8. Air cleaner restriction sending unit
9. 13-function instrument cluster:
  - a. Battery charge indicator
  - b. Low engine oil pressure indicator
  - c. Air cleaner restriction indicator
  - d. Parking brake indicator
  - e. Spare
  - f. Parking lights indicator
  - g. High beam indicator
  - h. Tractor turn signal indicator
  - i. 1st trailer turn signal indicator
  - l. 2nd trailer turn signal indicator
  - m. Water temperature gauge
  - n. Fuel gauge
  - p. Instrument panel light
10. Starter
11. Hand brake/stop lights indicator relay switch
12. Starter inhibitor switch
13. Parking brake flasher with indicator
14. Starter switch
15. Lighting switch and horn button
16. Single-pole power point
17. Hazard warning/turn signal flasher
18. Engine shut-off solenoid
19. Fuse box
20. Thermostarter/button start-pilot
21. Thermostarter
22. Turn signal switch
23. Hazard warning switch with indicator
24. Front parking and turn signal lights
25. Stop light switch
26. Parking brake indicator switch
27. Rear parking, turn signal and stop lights
28. Seven-conductor power point
29. Work light and switch
30. Start Pilot
31. Overvoltage protection device
32. Cab connector (optional)

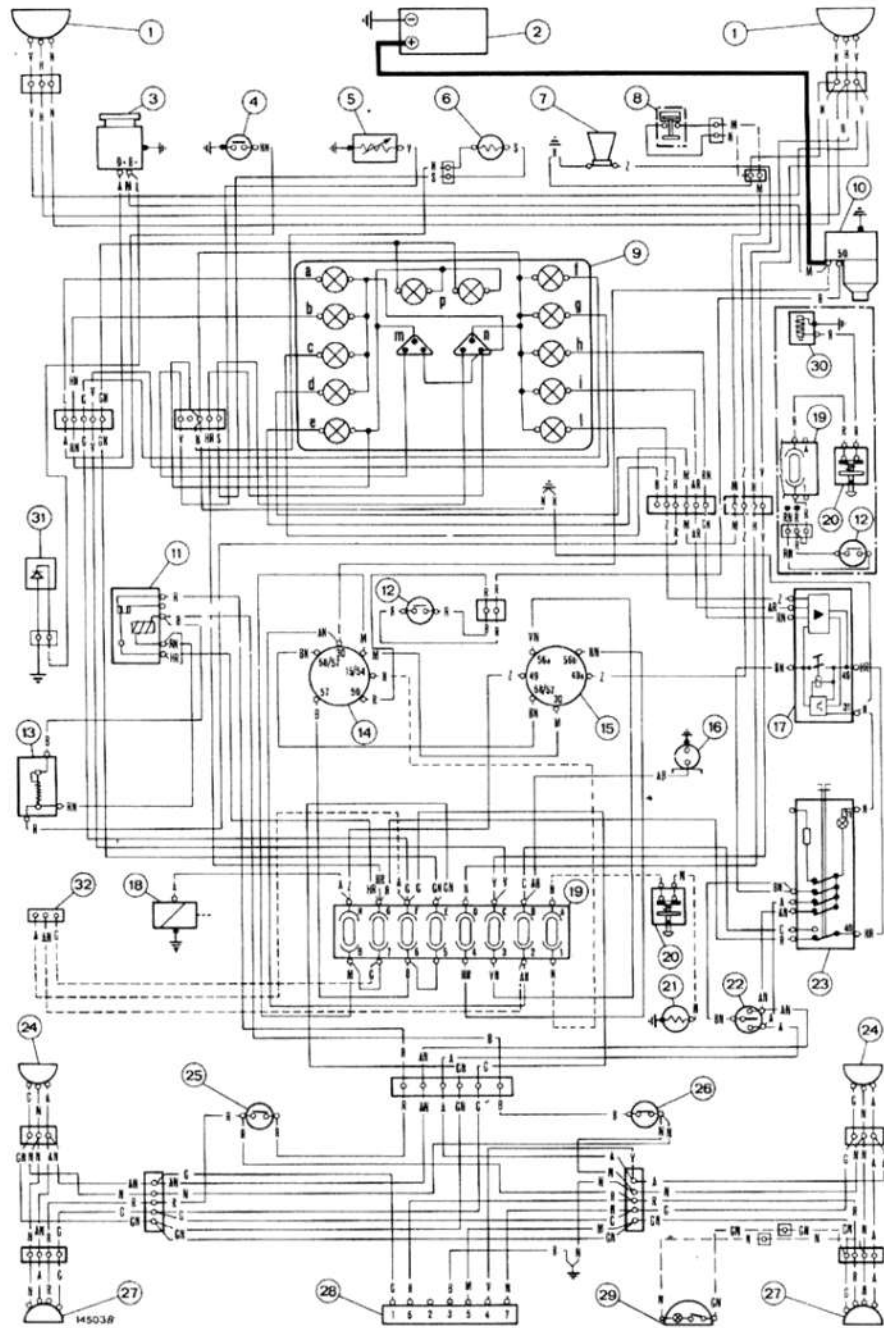

**CABLE COLOUR CODE**

- |                |           |
|----------------|-----------|
| A = Light blue | M = Brown |
| B = White      | N = Black |
| C = Orange     | R = Red   |
| G = Yellow     | S = Pink  |
| H = Grey       | V = Green |
| L = Dark blue  | Z = Mauve |

**ELECTRICAL SYSTEM:**

**10 - ENGINE****100 - Removal - Installation - Bench test.**

- 290740/1** Hook, lift.  
**290090** Stand, rotary.  
**293860** Bracket set, use with rotary stand **290090**.  
**291309/1** Tester, compression (kit **292631**).

**101 - Engine block - Cylinder head.**

- 292507** Plate, liner removal.  
**291501** Plate, liner installation.  
**292240 (390425)** Tap (M12x1.75), injector sleeve.  
**292243 (390771)** Clean-up tool, injector sleeve.  
**293784 (342137)** Puller, injector sleeve.  
**293742/2** Reamer set, injector sleeve.  
**293861** Burnisher, injector sleeve.  
**291113** Support fixture, cylinder head.  
**292248** Quadrant, cylinder head hold-down bolt angle tightening.

**102 - Valve gear.**

- 293269 (390363)** Reamer, camshaft bushings.  
**292103 (360383)** Remover-replacer set, camshaft bushings - use with **292208 (370008)**.  
**292208 (370008)** Handle.  
**291046/1 (360409/1)** Puller, engine valve guide.  
**291177 (390310)** Reamer, engine valve guide.  
**292913** Lathe, universal, valve seats.  
**291780 (360409/3)** Installer, exhaust and inlet valve guide (use with **291046/1**).  
**291978** Reamer set, valve seats (instead of **292913**).  
**290064** Grinder, valve.  
**291050** Remover/replacer, valve spring.  
**291112** Support, valve.  
**291883 (350108)** Wrench, valve clearance.

**103 - Crank gear.**

- 291504** Puller, crankshaft pulley hub.  
**291160** Pliers, piston ring.  
**291048** Installer, piston ring.

**104 - Fuel system**

- 293780** Hand pump, injector calibration check.  
**293671** Cleaners, injectors.  
**290898** Support, injector removal/installation (FIAT-OMAP).  
**293760** Support, injector removal/installation (BOSCH-CAV-OMAP).  
**293761** Wrenches, injectors.  
**293786** Wrench, injection pump pressure connections.

**On-bench injection pump test equipment.**

- 290239** Support, adjustable.  
**290756** Drive coupling.  
**292147** Spacer, injection pump test.  
**290765** Delivery lines (test A, 6x2x850 mm).  
**290752** Plate, pump support.  
**293149** Test stand, injection pump.  
**292197** Dial gauge (1/100 mm, stroke 30 mm dia 60 mm).  
**291754** Dial gauge (1/100 mm, stroke 5 mm, dia. 40 mm).  
**291755** Gauge, injection pump assembly.  
**293401** Kit, on-tractor injection pump check.

**BOSCH injection pump.**

- 290664 (365149)** Remover-replacer pump rotor.  
**290774** Gauge, distributing piston stroke.  
**290779** Installer, O-ring.  
**290780** Remover, O-ring.  
**292548** Protector, O-ring.  
**291750** Extension, M8x1 (for use with **290774**).  
**292553 (342141)** Remover, pressure regulating valve roll pin.  
**292554** Protector, cam ring.  
**292555/1** Remover/replacer, pump shaft.  
**292557/1** Compressor, pressure regulating valve.  
**291747 (352142)** Wrench, governor shaft.  
**291748 (352140)** Wrench, plug.

<b>291752</b>	Gauge, excess fuel stroke.
<b>291912</b> <b>(352141)</b>	Wrench, governor support screw.
<b>291751</b>	Tester, automatic advance.
<b>292197</b>	Dial gauge (1/100 mm - stroke 30 mm - dia. 60 mm).
<b>292239</b>	Installer, O-ring.
<b>291749</b> <b>(352139)</b>	Wrench, pressure regulating valve.

**CAV injection pump.**

<b>290741</b>	Guide, throttle lever spindle removal.
<b>290744</b>	Remover/replacer, transfer pump rotor (use with torque wrench).
<b>290745</b>	Guide, start-retard O-ring replacer.
<b>290746</b>	Guide, advance plug O-ring replacer.
<b>290757</b>	Gauge, timing, pump flange.
<b>290758</b>	Remover/replacer, cam ring pin.
<b>292249</b>	Tester, advance.
<b>292251</b>	Wrench (TORX 15).
<b>292252</b>	Wrench (TORX 20).
<b>292253</b>	Wrench (TORX 25).
<b>292254</b>	Guide, drive shaft seal installation.
<b>292397</b>	Connector, transfer pressure.
<b>292401</b>	Gauge, timing (use with <b>290757</b> ).
<b>292405</b>	Insert (use with <b>290757</b> ).
<b>292411</b>	Pin, timing.
<b>292412</b>	Adapter set (use with <b>292249</b> ).
<b>292414</b>	Tester, feed pressure.
<b>292415</b>	Connector, drain.
<b>292430</b>	Connector, inlet.
<b>292439</b>	Connector, pump leakage test.
<b>292400</b>	Plug, pump leakage test.

**106 - Cooling system.**

<b>291182/1</b>	Puller, water pump impeller.
<b>291968</b>	Tester set, coolant temperature.

**20 - POWER TRAIN****201 - Clutch.**

<b>292320</b>	Stand
<b>291291/2</b>	Kit, universal overhaul (early model).
<b>293650</b>	Kit, universal, overhaul (late model).
<b>292604</b>	Centralizer/adjuster, clutch on tractor.
<b>292605</b>	Register, clutch adjustments (w/ <b>292604</b> )
<b>292176</b>	Compressor, release lever test.

**202 - Transmission and splitter.**

<b>291517</b>	Hook, lift, transmission housing.
<b>292888</b>	Guide pins, clutch housing removal/installation.

**204 - Bevel drive and differential.**

<b>291517</b>	Hook, lift, rear drive housing.
<b>293400/1</b>	Gauge, bevel pinion position.
<b>292576</b>	Compressor, differential lock fork spring.
<b>291525</b>	Installer, differential supports.

**205 - Brakes.**

<b>293847</b>	Installer, brake link bellows.
---------------	--------------------------------

**206 - Final drives.**

<b>292400</b>	Hook, lift, rear wheels.
<b>291517</b>	Hook, lift.
<b>293850</b>	Installer, final drive seals (use with <b>293800</b> ).
<b>293800</b>	Handgrip.
<b>291525</b>	Installer, final drive cover.

**207 - Power take-off.**

<b>293838</b>	Installer, PTO shaft needle roller bearings.
---------------	--

**30 - FRONT AXLE - STEERING****303 - Power steering**

<b>293388</b>	Installer, O-ring, steering box.
<b>293389</b>	Installer, rotary valve spring.
<b>292390</b>	Retainer, rotor shaft.
<b>293300</b>	Kit, pressure gauge (use with <b>293160</b> ) steering gear on tractor.

**Steering hydraulic test equipment.**

<b>291231</b>	Tester, pump output.
<b>293005</b>	Tank.
<b>291235</b>	Electric motor (6-10 HP).
<b>or</b>	
<b>292150</b>	Electric motor (9-15 HP).
<b>290385</b>	Union.
<b>293165</b>	Hydraulic pump.
<b>293723</b>	Support.
<b>292256</b> }	Brackets (use with <b>292723</b> ).
<b>292257</b> }	
<b>292724</b>	Screw (2 off).
<b>293192/1</b>	Wrench, rotary valve.
<b>290445</b>	Pipe, suction.
<b>290448</b> }	Adapter, suction pipe.
<b>290540</b> }	
<b>293316</b>	Adapter (2 off), suction and delivery pipes.
<b>290544</b>	Pipe, delivery.
<b>290475</b>	Connector, 3-way.
<b>290541</b>	Adapter, return pipe.
<b>290447</b>	Pipe, return.
<b>293315</b>	Plug (2 off).
<b>293721</b>	Connection, oil drain.
<b>292775</b>	Pipe, oil drain.

**40 - FRONT WHEEL DRIVE****401 - Front axle.**

<b>292116</b>	Hook, lift, ballast support.
<b>293782</b>	Wrench, front axle bevel pinion (use with <b>293785</b> ).
<b>293785</b>	Wrench, front bevel pinion lock ring (use with <b>293782</b> ).
<b>291525</b>	Pins, planetary final drive cover installation.
<b>293812</b>	Pins, front wheel installation.
<b>293460</b> <b>(322215)</b>	Stand, front axle overhaul.
<b>293836</b>	Guard, axle drive shaft seal installation.
<b>293743</b>	Support, differential bevel pinion housing.
<b>293520/2</b>	Wrench, bevel pinion bearing lockring and rolling torque check.
<b>293400/1</b>	Gauge, bevel pinion position (use with <b>293752</b> or <b>293510</b> ).
<b>293510</b>	Adjuster, universal, bevel pinion bearings.
<b>293752</b>	Adjuster specific bevel pinion bearing.
<b>293544</b>	Wrench, differential bearing lockring.

<b>293837</b>	Wrench, wheel bearing lockring.
<b>292220/3</b>	Tester, bearing rolling torque.
<b>293857</b>	Puller, live front axle articulation pivot.

**50 - LIFT UNIT****501 - Lift.**

<b>290284</b>	Pump, hand, valve adjustment.
<b>293300</b>	Tester, pressure, universal (pressure gauges and connectors).
<b>292547</b>	Installer, piston with lift seal.
<b>292535</b>	Protector/installer, lift cross shaft seal.
<b>290828</b>	Adapter, cylinder safety valve adjustment (use with <b>290284</b> ).
<b>290824</b>	Adapter, relief valve adjustment (use with <b>290284</b> ).
<b>293849</b>	Adapter, control valve spool leakage check (use with <b>290284</b> ).
<b>291862</b>	Wrench, cylinder safety valve adjustment.
<b>291863</b>	Wrench, relief valve adjustment.
<b>291215</b>	Hook, link - control valve lever retaining spring.
<b>293839</b>	Installer, needle roller bearing, control valve spool lever
<b>293838</b>	Installer, needle roller bearing, draft upper/lower levers.
<b>293846</b>	Adjuster, lift draft and position control.
<b>293872</b>	Connector (w/ <b>293846</b> ).
<b>293845/1</b>	Adjuster, lift draft control (with <b>293846</b> ).
<b>293844/1</b>	Adjuster, arm max lift.
<b>293858</b>	Protection, link lowering valve, spool seal installation.
<b>293463</b>	Wrench, remote control valve overpressure valve sleeve
<b>292650</b>	Bertch, lift test.
<b>293851</b>	Tank.
<b>293852</b>	Union.
<b>293853</b>	Pipe.
<b>293854</b>	Pins and bushings.

**502 - Lift pump A31 and C18.**

- 293600** Stand, rotary, pump overhaul (to clamp in vise).
- 291231** Tester, output, large, complete with:
- 290417** - Union, inlet
- 290418** - Union, outlet
- 290448** - Adapter, inlet
- 290445** - Pipe, inlet
- 290447** - Pipe, delivery
- 290434** - Screen, inlet/outlet unions.
- 291235** Motor, electric, pump drive, complete with:
- 290385** - Coupling, drive.

**504 - Remote control valves.**

- 291231** Tester, output, large, complete with:
- 291235<sup>(1)</sup>** - Electric motor
- 293005** - Tank
- 293165** - Hydraulic pump
- 290385** - Union
- 293548/1** - Valve support
- 292256** - Bracket

<sup>(1)</sup> Electric motor **291235** is indicated as an alternative to 15 HP electric motor **292150**.

- 292257** - Bracket
- 290469/1** - Support
- 293539** - Burette
- 290448** - Reduction
- 290445** - Pipe
- 290419** - Inlet pipe
- 293556** - Screw
- 293316** - Reduction
- 293544** - Pipe
- 293532** - Connection
- 290503** - Reduction
- 290378** - Drain pipe
- 290541** - Reduction
- 290447** - Return pipe
- 293552** - Plug
- 290383** - Plug
- 293553** - Connection
- 290424** - Pipe
- 293459** - Ball union
- 292146** }  
or } - Connection, 3-way
- 290475** }
- 293547** - Reduction
- 292152** - Reduction
- 293550** - Connection.

**60 - ELECTRICAL SYSTEM.**

- 293599** Support, alternator bench test.

# **FIAT**

## **Trattori**

**45-66 V    45-66 DTV**  
**55-66 V    55-66 DTV**  
**55-66 F    55-66 DTF**  
**60-66 F    60-66 DTF**  
**70-66 F    70-66 DTF**  
**80-66 F    80-66 DTF**

### **WORKSHOP MANUAL**

#### **INDEX**

	Section
<b>GENERAL . . . . .</b>	<b>A</b>
<b>SPECIFICATIONS . . . . .</b>	<b>00</b>
<b>ENGINE . . . . .</b>	<b>10</b>
<b>POWER TRAIN . . . . .</b>	<b>20</b>
<b>FRONT AXLE — STEERING . . . . .</b>	<b>30</b>
<b>FRONT WHEEL DRIVE . . . . .</b>	<b>40</b>
<b>HYDRAULIC LIFT UNIT . . . . .</b>	<b>50</b>
<b>ELECTRICAL SYSTEM . . . . .</b>	<b>60</b>
<b>SERVICE TOOLS . . . . .</b>	<b>90</b>

**S E R V I Z I   T E C N I C I   D I   A S S I S T E N Z A**

**FIAT TRATTORI S.p.A. - Viale delle Nazioni, 55 - S. Matteo - 41100 MODENA - Italy**

Servizi Tecnici di Assistenza - Pubblicazioni Tecniche - Print No. **603.54.228.02** - X - 1987 - 2000 - MUCCHI

Print No. **603.54.228.02** - X - 1987

	Page	Date		Page	Date
<b>A - GENERAL</b>			<b>100 - ENGINE - Description - Performance Data - Removal - Installation</b>		
General instructions - See Mods. 466/566/666/766	6-7	VII-1984	Description	1	IX-1985
Safety precautions - See Mods. 466/566/666/766	8-9-10	VII-1984	Performance Data	1-2	IX-1985
			Compression Test - See Mods. 466/566/666/766	4	VII-1984
			Removal - Installation - See Mods. 466/566/666/766	4-5	VII-1984
<b>00 - SPECIFICATIONS</b>			<b>101 - ENGINE - Engine block - Cylinder head</b>		
Identification data - Weights	1	X-1987	Barrel liners:		
Engine	2-3	X-1987	● Mod. 45-66V - See Mod. 55-66	1-2	IX-1985
Power train - Brakes - Steering - Front axle - Live front axle - Rear Wheels - Power take-off - Hydraulic lift	4	X-1987	● Others - See Mods. 55-66/60-66/70-66/80-66	1-2	IX-1985
Towing attachments - Front axle ballasting - Electrical system - Lighting equipment - Instruments and accessories - Tire sizes	5	X-1987	Cylinder head:		
Main dimensions	6-7	X-1987	● Mod. 45-66V - See Mod. 55-66	2-3-4	IX-1985
Power train schematics	8-9	X-1987	● Others - See Mods. 55-66/60-66/70-66/80-66	2-3-4	IX-1985
Fluid capacities	10	X-1987			
<b>10 - ENGINE: Specifications and Data</b>			<b>102 - ENGINE - Valve gear</b>		
Engine block - Cylinder head:			Camshaft - Valves, guides and springs:		
● Mod. 45-66V - See Mod. 55-66	1	IX-1985	● Mod. 45-66V - See Mod. 55-66	1	IX-1985
● Others - See Mods. 55-66/60-66/70-66/80-66	1	IX-1985	● Others - See Mods. 55-66/60-66/70-66/80-66	1	IX-1985
Crank gear:			Tappets, pushrods and rockers: See Mods. 55-66/60-66/70-66/80-66	1	IX-1985
● Mod. 45-66V - See Mod. 55-66	2-3-4-5	IX-1985	Valve timing gears - See Mods. 466/566/666/766	3	VII-1984
● Others - See Mods. 55-66/60-66/70-66/80-66	2-3-4-5	IX-1985			
Valve gear:			<b>103 - ENGINE - Crank gear</b>		
● Mod. 45-66V - See Mod. 55-66	5-6-7	IX-1985	Crankshaft:		
● Others - See Mods. 55-66/60-66/70-66/80-66	5-6-7	IX-1985	● Mod. 45-66V - See Mod. 55-66	1	IX-1985
Lubrication system:			● Others - See Mods. 55-66/60-66/70-66/80-66	1	IX-1985
● Mod. 45-66V - See Mod. 55-66	8	IX-1985	Main/Big end bearings and caps: See Mods. 466/566/666/766	2-3	VII-1984
● Others - See Mods. 55-66/60-66/70-66/80-66	8	IX-1985	Pistons and rings:		
Cooling system:			● Mod. 45-66V - See 55-66	1-2	IX-1985
● Mod. 45-66V - See Mod. 55-66	8-9	IX-1985	● Others - See Mods. 55-66/60-66/70-66/80-66	1-2	IX-1985
● Others - See Mods. 55-66/60-66/70-66/80-66	8-9	IX-1985	Connecting rods:		
Fuel system:			● Mod. 45-66V - See Mod. 55-66	2	IX-1985
● Mod. 45-66V - See Mod. 45-66	1-2	X-1987	● Others - See Mods. 55-66/60-66/70-66/80-66	2	IX-1985
● Others - See Mods. 55-66/60-66/70-66/80-66	9 thru 18	IX-1985	Flywheel - See Mods. 466/566/666/766	5	VII-1984
Torque Data:			Dynamic balancer: See Mods. 70-66/80-66	2	IX-1985
● Mod. 45-66V - See Mod. 55-66	19-20	IX-1985			
● Others - See Mods. 55-66/60-66/70-66/80-66	19-20	IX-1985	<b>104 - ENGINE - Fuel system</b>		
Engine sections:			Removal, installation and timing of injection pump on engine - See Mod. 55-66	1-2-3	X-1987
● Mod. 45-66V - See Mod. 55-66	21	IX-1985			
● Others - See Mods. 55-66/60-66/70-66/80-66	21-22	IX-1985	<b>105 - ENGINE - Lubrication system</b>		
			3-cyl engine lubrication system schematics - See Mods. 466 and 566	1	VII-1984

# GENERAL: Contents

	Page	Date		Page	Date
4-cyl. engine lubrication system schematics - See Mods. 666 and 766 . . .	2	VII-1984			
Oil pump - Oil filter - Low oil pressure warning indicator - See Mods. 466/566/666/766 . . . . .	3	VII-1984			
<b>106 - ENGINE - Cooling system</b>					
Cooling system schematics:					
● Mod. 45-66V - See Mod. 55-66 . . .	1	IX-1985			
● Others - See Mods. 466/566/666/766 . . . . .	1	IX-1985			
Description - See Mods. 466/566/666/766 . . . . .	2	VII-1984			
Water pump - See Mods. 55-66/60-66/70-66/80-66 . . . . .	2	IX-1985			
Radiator - See Mods. 466/566/666/766 . . . . .	3	VII-1984			
Drive belt tension adjustments - See Mods. 55-66/60-66/70-66/80-66 . . . . .	2	IX-1985			
Water temperature gauge - Thermostat - See Mods. 466/566/666/766 . . . . .	4	VII-1984			
<b>20 - POWER TRAIN - Specifications and Data</b>					
Clutches . . . . .	1	X-1987			
Transmission and splitter . . . . .	1	X-1987			
Creepers . . . . .	1	X-1987			
Reverser . . . . .	1	X-1987			
Rear bevel drive and differential . . . . .	1	X-1987			
Brakes . . . . .	1	X-1987			
Side final drives . . . . .	1	X-1987			
Power Take Off . . . . .	1	X-1987			
Torque Data . . . . .	1	X-1987			
Power train cross-section - Mods. 45-66V/55-66V/55-66F . . . . .	2	X-1987			
Power train longitudinal section - Mods. 45-66V/55-66V/55-66F . . . . .	3	X-1987			
Power train cross-section - Mods. 60-66F/70-66F/80-66F . . . . .	4	X-1987			
Power train longitudinal section - Mods. 60-66F/70-66F/80-66F - See Mods. 55-66LP/60-66LP/70-66LP . . . . .	4	X-1987			
<b>201 - POWER TRAIN - Clutch</b>					
VALEO Clutch servicing . . . . .	1	X-1987			
VALEO clutch adjustments . . . . .	1	X-1987			
LUK clutch servicing . . . . .	1	X-1987			
LUK clutch adjustments . . . . .	1	X-1987			
Clutch control linkage adjustments . . . . .	1-2	X-1987			
<b>202 - POWER TRAIN - Transmission and splitter</b>					
Removal and installation . . . . .	1	X-1987			
Disassembly . . . . .	1-2	X-1987			
Transmission/Splitter longitudinal and cross sections . . . . .	1-2	X-1987			
Inspection - Assembly					
● Mod. 45-66V/55-66V/55-66F - See Mod. 45-66 . . . . .	5-6	X-1987			
● Mod. 60-66F/70-66F/80-66F - See Mods. 55-66/60-66/70-66/80-66 . . . . .	4	IX-1985			
<b>203 - POWER TRAIN - Creeper and mechanical reverser</b>					
Creeper: Description - Servicing					
● Mods. 45-66V/55-66V/55-66F - See Mod. 45-66 . . . . .	1-2	X-1987			
● Mods. 60-66F/70-66F/80-66F - See Mods. 466/566/666/766 . . . . .	1-2-3	VII-1984			
Reverser: Description - Servicing					
● Mods. 45-66V/55-66V/55-66F - See Mod. 45-66 . . . . .	2-3-4	X-1987			
● Mods. 60-66F/70-66F/80-66F - See Mods. 466/566/666/766 . . . . .	3-4	VII-1984			
<b>204 - POWER TRAIN - Bevel drive and differential</b>					
Removal - Installation - Disassembly - Assembly of bevel drive and differential . . . . .	1	X-1987			
Bevel pinion shaft removal . . . . .	1	X-1987			
Bevel drive adjustment . . . . .	1	X-1987			
Differential pinion/side gear backlash adjustment . . . . .	1	X-1987			
Bevel drive/differential longitudinal and cross sections . . . . .	1-2	X-1987			
Differential lock installation and adjustment . . . . .	1-2	X-1987			
<b>205 - POWER TRAIN - Brakes</b>					
Brake unit removal and installation . . . . .	1	X-1987			
Brake pedal adjustments:					
● Mods. 45-66V/55-66V/55-66F . . . . .	1	X-1987			
● Mods. 60-66F/70-66F/80-66F . . . . .	2	X-1987			
Parking brake hand lever adjustments:					
● Mods. 45-66V/55-66V/55-66F . . . . .	1	X-1987			
● Mods. 60-66F/70-66F/80-66F . . . . .	2	X-1987			
Brake operation - See Mods. 466/566/666/766 . . . . .	5	IX-1983			
<b>206 - POWER TRAIN - Side final drives</b>					
Removal . . . . .	1	X-1987			
Disassembly - Assembly . . . . .	1	X-1987			
<b>207 - POWER TRAIN - Power Take Off</b>					
Removal - Installation:					
● Mods. 45-66V/55-66V/55-66F - See Mod. 45-66 . . . . .	1-2	X-1987			
● Mods. 60-66F/70-66F/80-66F - See Mods. 466/566/666/766 . . . . .	1-2	VII-1984			
PTO longitudinal section:					
● Mods. 45-66V/55-66V/55-66F - See 45-66 . . . . .	1	X-1987			
● Mods. 60-66F/70-66F/80-66F - See Mods. 466/566/666/766 . . . . .	2	VII-1984			

**30 - FRONT AXLE - STEERING: Specifications and Data**

	Page	Date
Front axle . . . . .	1	X-1987
Hydrostatic power steering . . . . .	1-2	X-1987
Torque Data - See Mods. 466/566/666/766 . . . . .	5	VII-1984

**301 - FRONT AXLE - STEERING: Dead front axle**

Front wheel geometry checks:		
● Mods. 45-66V/55-66V/55-66F . . . . .	1	X-1987
● Mods. 60-66F/70-66F/80-66F - See Mods. 466/566/666/766 . . . . .	2	VII-1984
Front wheel hub bearing adjustments:		
● Mods. 46-55V/55-66V/66-66F . . . . .	1	X-1987
● Mods. 60-66F/70-66F/80-66F - See Mods. 466/566/666/766 . . . . .	2	X-1987

**303 - FRONT AXLE - STEERING: Power steering**

Power steering servicing - See Mods. 466/566/666/766 . . . . .	1	VII-1984
Hydraulic pump and reservoir servicing - Hydraulic system bleeding - See Mods. 55-66/60-66/70-66/80-66 . . . . .	2	IX-1985
Rotary valve wear check - See Mods. 466/566/666/766 . . . . .	5	VII-1984
Return to neutral check - See Mods. 466/566/666/766 . . . . .	5	VII-1984
Seal check - See Mods. 466/566/666/766 . . . . .	5	VII-1984
Relief valve setting - See Mods. 466/566/666/766 . . . . .	5	VII-1984
Cylinder safety valve setting - See Mods. 466/566/666/766 . . . . .	6	VII-1984
Power steering control valve servicing - See Mods. 466/566/666/766 . . . . .	7	VII-1984
Operation schematics and sections - See Mods. 466/566/666/766 . . . . .	10-11	VII-1984
Trouble shooting chart - See Mods. 466/566/666/766 . . . . .	8-9	VII-1984

**40 - FRONT WHEEL DRIVE - Specifications and Data**

Live front axle . . . . .	1-2	X-1987
Axle drive - Drive shafts . . . . .	2	X-1987

**401 - FRONT WHEEL DRIVE: Live front axle**

Removal - Side final drives, wheel hubs and steering articulation servicings . . . . .	1	X-1987
Steering knuckle kingpin bearing adjustments . . . . .	1-2	X-1987

	Page	Date
Wheel hub bearings adjustment . . . . .	2	X-1987
Bevel drive/Differential unit servicing . . . . .	2	X-1987
Bevel drive gear adjustments . . . . .	2-3-4-5	X-1987
Axle center swing pivot pin adjustment - Mods. 45-66DTV and 55-66DTV . . . . .	5	X-1987
NO-SPIN differential unit - See Mod. 45-66 . . . . .	3	X-1987

**402 - FRONT WHEEL DRIVE: Drive shafts - Axle drive**

Drive shaft removal and installation - Axle drive removal . . . . .	1	X-1987
Axle drive installation . . . . .	1	X-1987
Front wheel drive sections . . . . .	2-3-4	X-1987

**50 - HYDRAULIC LIFT UNIT: Specifications and Data**

Lift:		
● Mods. 45-66V/55-66V/55-66F - See Mod. 45-66 . . . . .	1	X-1987
● Mods. 60-66F/70-66F/80-66F - See Mods. 55-66 and 60-66 . . . . .	1	IX-1985
Hydraulic pump - See Mods. 55-66/60-66/70-66/80-66 . . . . .	2	IX-1985
Remote control valves - See Mods. 55-66/60-66/70-66/80-66 . . . . .	3	IX-1985
Lift trouble shooting chart - See Mods. 466/566/666/766 . . . . .	6	VII-1984
Torque Data:		
● Mods. 45-66V/55-66V/55-66F - See Mod. 45-66 . . . . .	2	X-1987
● Mods. 60-66F/70-66F/80-66F - See Mod. 466/566/666/766 . . . . .	7	VII-1984

**501 - HYDRAULIC LIFT UNIT - Lift**

Description - See Mods. 466/566/666/766 . . . . .	1	VII-1984
Disassembly - Inspection - Assembly:		
● Mods. 45-66V/55-66V/55-66F - See Mod. 45-66 . . . . .	1-2-3-4	X-1987
● Mods. 60-66F/70-66F/80-66F - See Mod. 466/566/666/766 . . . . .	2 thru 7	X-1987
Position control adjustment - Mod. 45-66V/55-66V/55-66F . . . . .	1	X-1987
On-bench max lift arm travel adjustment - Mod. 45-66V/55-66V/55-66F . . . . .	1-2	X-1987
Draft control adjustments - Mod. 45-66V/55-66V/55-66F . . . . .	2 thru 5	X-1987
Draft/position control rod linkage adjustments - Mod. 45-66V/55-66V/55-66F . . . . .	5	X-1987

**GENERAL:  
Contents**

	<b>Page</b>	<b>Date</b>
LIFT-O-MATIC adjustment - Mods. 45-66V/55-66V/55-66F . . . . .	5	X-1987
On-Tractor max lift arm travel adjustment - Mods. 45-66V/55-66V/55-66F . . . . .	6	X-1987
Position control adjustment - Mods. 60-66F/70-66F/80-66F . . . . .	6	X-1987
On-bench max lift arm travel adjustment - Mods. 60-66F/70-66F/80-66F . . . . .	6	X-1987
Draft control adjustment - Mods. 60-66F/70-66F/80-66F . . . . .	6	X-1987
Position and draft control rod linkage adjustment - Mods. 60-66F/70-66F/80-66F . . . . .	6-7	X-1987
LIFT-O-MATIC adjustment - Mods. 60-66F/70-66F/80-66F . . . . .	7	X-1987
On-tractor max lift arm travel adjustment - Mods. 60-66F/70-66F/80-66F . . . . .	7	X-1987
Valve checks - See Mods. 55-66/60-66/70-66/80-66 . . . . .	4	IX-1985
Lift hydraulic system schematics: ● Mods. 45-66V/55-66V/55-66F - See Mods. 45-66 . . . . .	12	X-1987
● Mods. 60-66F/70-66F/80-66F - See Mods. 466/566/666/766 . . . . .	14-15	VII-1984
 <b>502 - HYDRAULIC LIFT UNIT: Lift pump</b>		
Servicing - See Mods. 466/566/666/766 . . . . .	1-2	VII-1984
Output test - See Mods. 466/566/666/766 . . . . .	2	VII-1984

	<b>Page</b>	<b>Date</b>
<b>503 - HYDRAULIC LIFT UNIT: Implement attachment</b>		
Implement attachment - RH lifting rod . . . . .	1	X-1987
Draft control device . . . . .	2	X-1987
 <b>504 - HYDRAULIC LIFT UNIT - Remote control valves</b>		
Description and operation - See Mods. 466/566/666/766 . . . . .	1	VII-1984
Hydraulic system schematics - See Mods 466/566/666/766 . . . . .	1-2-3	VII-1984
Disassembly - See Mods. 466/566/666/766 . . . . .	4-5	VII-1984
Pressure relief valve setting - See Mods. 466/566/666/766 . . . . .	5	VII-1984
Valve spool return test - See Mods. 466/566/666/766 . . . . .	6	VII-1984
Remote control valve leakage test - See Mods. 466/566/666/766 . . . . .	7	IX-1985
 <b>60 - ELECTRICAL SYSTEM - Specifications and Data</b>		
Battery charge system . . . . .	1	X-1987
Starter motor . . . . .	1	X-1987
Battery and fuses . . . . .	1	X-1987
Lighting - Signals - Accessories - See Mods. 466/566/666/766 . . . . .	13	IX-1983
Switches . . . . .	1	X-1987
Instrument panel . . . . .	1	X-1987
Fusebox - See Mods. 466/566/666/766 . . . . .	15	IX-1983
Wiring diagram - Mods. 45-66V/55-66V/55-66F . . . . .	2	X-1987
Wiring diagram - Mods. 60-66F/70-66F/80-66F: See Mods. 55-66LP/60-66LP/70-66LP . . . . .	2	X-1987
 <b>90 - SERVICE TOOLS . . . . .</b>	1	X-1987

**IDENTIFICATION DATA**

Marketing Code

- Two wheel drive .....
- Four wheel drive .....

Engineering code:

- 12-speed, two-wheel drive .....
- 12-speed, two-wheel drive with mechanical reverser .....
- 20-speed, two-wheel drive .....
- 12-speed, four-wheel drive .....
- 12-speed, four-wheel drive with mechanical reverser .....
- 20-speed, four-wheel drive .....

Engine tupe (common to all versions)

**WEIGHTS**

Operating weight (including lift, implement attachment, tow hook)

- Two-wheel drive .....
- Four-wheel drive .....

45-66V 45-66DTV	55-66V 55-66DTV	60-66V 55-66DTF	70-66V 60-66DTF	80-66V 70-66DTF	80-66DTF
674.106.001	674.106.000	674.108.000	670.108.000	671.108.000	672.108.000
—	—	—	670.108.000 var.720.110	671.108.000 var.720.110	672.108.000 var.720.110
674.106.001 var.720.111	674.106.000 var.720.111	674.108.000 var.720.111	670.108.000 var.720.111	671.108.000 var.720.111	672.108.000 var.720.111
674.114.001	674.114.000	674.113.000	670.113.000	671.113.000	672.113.000
674.114.001 var.720.110	674.114.000 var.720.110	674.113.000 var.720.110	670.113.000 var.720.110	671.113.000 var.720.110	672.113.000 var.720.110
674.114.001 var.720.111	674.114.000 var.720.111	674.113.000 var.720.111	670.113.000 var.720.111	671.113.000 var.720.111	672.113.000 var.720.111
FIAT 8.035.06.320 C.A.V. pump	FIAT 8.035.06.322 C.A.V. pump	FIAT 8.035.06.322 C.A.V. pump	FIAT 8.035.05.308 C.A.V. pump	FIAT 8.045.06.308 C.A.V. pump	FIAT 8.045.05.308 C.A.V. pump
8.035.06.220 BOSCH pump	8.035.06.222 BOSCH pump	8.035.06.222 BOSCH pump	8.035.05.208 BOSCH pump	8.045.06.208 BOSCH pump	8.045.05.208 BOSCH pump
kg lb	kg lb	kg lb	kg lb	kg lb	kg lb
1530 3366	1530 3366	1490 3278	1940 4268	2040 4488	2160 4752
1730 3806	1730 3806	1665 3663	2135 4697	2255 4961	2320 5104

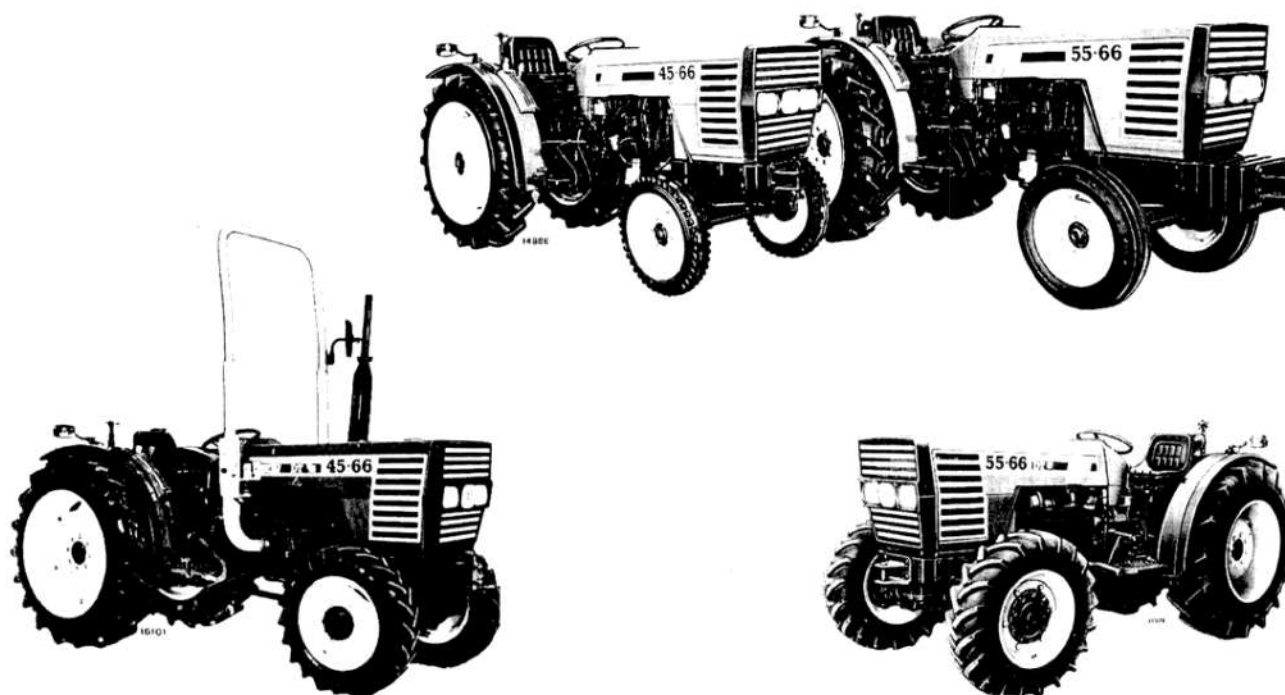

**ENGINE**

Diesel cycle . . . . .  
 Injection system . . . . .  
 No. of cylinders . . . . .  
 Barrel liners . . . . .  
 Bore x stroke . . . . .  
 Total piston displacement . . . . .  
 Compression ratio . . . . .  
 Max power (DGM/DIN) . . . . .  
 Max power speed rating . . . . .  
 Max torque speed rating . . . . .  
 Main bearings . . . . .  
 Sump . . . . .  
 Balancer . . . . .  
**Valve Gear** . . . . .  
 Intake { Opens: BTDC  
           Closes: ABDC  
 Exhaust { Opens: BBDC  
           Closes: ATDC  
 Valve clearance:  
 — For timing checks . . . . .  
 — For normal operation (both cold  
   and hot)  
 — Intake . . . . .  
 — Exhaust . . . . .

45-66V 45-66DTV	55-66V 55-66DTV	55-66F 55-66DTF	60-66F 60-66DTF	70-66F 70-66DTF	80-66F 80-66DTF
4-stroke, naturally aspirated direct					
3			4		
Dry, press-fitted in engine block					
100 x 115 (3.4 x 3.5 in) 2710		104 x 115 (4 x 4.5 in) 2931		100 x 115 (3.4 x 4.5 in) 3613	104 x 115 (4 x 4.5 in) 3908
17:1					
33.1 (45 HP)	40.5 (55 HP)	40.5 (55 HP)	44 (60 HP)	51.5 (70 HP)	58.9 (90 HP)
2500 RPM					
1500 RPM					
4				5	
cast iron					
Overhead, pushrod operated					
Flyweights engine sump					
3°					
23°					
48°30'					
6°					
0.45 (0.018 in)					
0.25 (0.010 in)					
0.35 (0.014 in)					



**Fuel System**

Air cleaner . . . . .

Dry, automatic drain, centrifugal pre-cleaner cap

Fuel filtration . . . . .

Single, cartridge type, integral with water separator

Two, in series, replaceable paper cartridge (the first w/ integral water separator)

Fuel lift pump . . . . .

double diaphragm type by cam

— Operation . . . . .

Injection pump . . . . .

rotary distributor, w/incorporated governor/advance variator

— Type { BOSCH . . . . .  
CAV . . . . .

45-66V 45-66DTV	55-66V 55-66DTV	55-66F 55-66DTF	60-66F 60-66DTF	70-66F 70-66DTF	80-66F 80-66DTF
VE3/11F 1250 L 163-2 4804867	VE3/11F 1250 L 163-1 4794587/	VE3/11F 1250 L 163-1 4794587/	VE3/11F 1250 L 163 4794586	VE4/11F 1250 L 164-1 4794589	VE4/11F 1250 L 164 4794588
DPS 8522A 020A 4806879	DPS 8522A 010A 4797414	DPS 8522A 010A 4797414	DPS 8522A 000A 4797413	DPS 8520A 100A 4797416	DPS 8520A 090A 4797415

Integral all-speed governor . . . . .

flyweights, centrifugal

Integral advance variator . . . . .

hydraulic

Pump timing BTDC

— BOSCH . . . . .

6° ± 1°	6° ± 1°	6° ± 1°	6° ± 1°	4° ± 1°	4° ± 1°
0° ± 1°	0° ± 1°	0° ± 1°	0° ± 1°	0° ± 1°	0° ± 1°

— CAV . . . . .

Injectors . . . . .

4-orifice | 3-orifice | 4-orifice | 3-orifice

— Type . . . . .

see page 10, Sect. 10 - Mods. 55-66/60-66/70-66/80-66

— Release pressure . . . . .

230 to 238 bar (235 to 243 kg/cm<sup>2</sup> or 3271 to 3385 psi)

Injection order . . . . .

1-2-3 | 1-3-4-2

**Lubrication System**

forced feed, gear pump

Pump drive . . . . .

Camshaft

Oil filters . . . . .

Strainer on pump inlet and full-flow on outlet

Pressure relief valve . . . . .

in pump body

— Lube oil pressure rating at governed speed (max power)

2.9 to 3.9 bar (3 to 4 kg/cm<sup>2</sup> or 42.6 to 55.5 psi)

**Cooling System**

water circulated by centrifugal pump

Radiator . . . . .

3 or 4 deep, vertical tubes

Fan mounted on water pump pulley

Suction, steel

Temperature control . . . . .

Wax thermostat

**Tractor Meter**

incorporated in panel instrument cluster

— Drive . . . . .

off oil pump gear

— Hourmeter activation speed . . . . .

1800 RPM

Meter drive ratio . . . . .

1:2

**POWER TRAIN****Clutch**

LUK or VALEO type, twin dry single plate, size 10 in (Mods. 45-66V/55-66V/55-66V) or 11 in (Mods. 60-66F/70-66F/80-66F) with separate controls: pedal for transmission clutch and hand lever for PTO clutch. Clutch facings material: organic.

**Transmission**

Constant-mesh, helical gears, with all-speed synchromesh shift.

Range splitter, 3 forward speeds and 1 reverse speed ranges providing 12 speeds forward and 4 reverses. In the crawler gear version, speeds available are 20 forward and 8 reverses.

In the mechanical reverser version, speeds available are 12 forward and 12 reverses.

Transmission and splitter control by two separate hand levers.

Crawler or reverser control by hand lever on LH side.

**Central bevel gear** on differential.

**Differential** of the two pinion type, with differential lock.

**Side final drives** of the epicyclic, three planetary gear design.

**BRAKES****Service**

Axle shaft mounted, oil bath disc type. Mechanically controlled through two separate pedals (latchable for one foot operation).

**Parking/Emergency**

Acting on service brakes, mechanically operated by hand lever.

**STEERING**

Hydrostatic power steering with independent circuits. Sealed for life control rod linkages.

**FRONT AXLE**

Center swing, telescoping inverted-U beam axle.

Sliding axle end track adjustments:

- Mods. 45-66V/55-66V/55-66F . . . . . 2 settings
- Mods. 60-66F/70-66F/80-66F . . . . . 4 settings

**LIVE FRONT AXLE**

Full-floating, center-swing, articulations and drive shaft on tractor centerline (with universal joints for Mods. 45-66DTV/55-66DTV or unjointed for Mods. 55-66DTF/60-66DTF/70-66DTF/80-66DTF). Two-pinion differential and planetary epicyclic final drives in wheel hubs (Mods. 55-66DTF/60-66DTF/70-66DTF/80-66DTF).

**REAR WHEELS**

Track width adjustments by relative re-positioning of Disc/Rim/Hub.:

- Mods. 45-66V/55-66V/55-66F . . . . . 6 settings
- Mods. 60-66F/70-66F/80-66F . . . . . 7 settings

**POWER TAKE-OFF****Fully Independent**

(540 or 540-1000 RPM)

- Shaft 540 RPM . . . . . 1 3/8" - 6 spline
- 1000 RPM . . . . . 1 3/8" - 21 spline

Control . . . . . mechanical, by hand lever  
Standard speed selection by hand lever.

Engine speed w/PTO at standard speeds:

- 540 . . . . . 2000 RPM
  - 1000 . . . . . 2380 RPM
- Rotation (seen from rear) . . . . . clockwise

**Ground speed**

Drive shaft and rotation same as fully independent PTO.

Shaft drive ratios (synchronized w/transmission):

- |        |   |                                    |                          |
|--------|---|------------------------------------|--------------------------|
| — 540  | } | 45-66V/55-66V-66V/55-66F . . . . . | 6.7 revs per wheel turn  |
|        |   | 60-66F/70-66F/80-66F . . . . .     | 7.7 revs per wheel turn  |
| — 1000 | } | 45-66V/55-66V-66V/55-66F . . . . . | 11.5 revs per wheel turn |
|        |   | 60-66F/70-66F/80-66F . . . . .     | 13.1 revs per wheel turn |

**HYDRAULIC LIFT**

Draft and position or combined control.

Draft control lower links through sensing bar

Sensitivity adjustment (Vario-speed) by 4-position lever on control valve housing.

Response adjustment by knob on control valve housing.

Button operated automatic link raise/lower device (LIFT-O-MATIC).

Engine valve gear-driven gear pump.

Control oil drawn from rear drive housing.

Implement attachment:

- 45-66V/55-66V . . . . . Cat. I
- 55-66F/60-66F/70-66F/80-66F . . . . . Cat. I and II

**Remote Control Valves**

One, two or three valves may be used.

- Single - and double-acting, convertible.
- Double-acting, float position.

**TOWING ATTACHMENTS**

Drilled crossmember (except vineyard mods)  
Rigid rear tow hook, height adjustable.  
Lemoine rear tow hook.  
Rockinger rear tow hook.  
Front pull hook.

**FRONT AXLE BALLASTING**

**Mods. 45-66V/55-66V/55-66F** - Three 30 kg (66 lb) cast iron plates for a total of 90 kg (198 lb).  
**Mods. 60-66F/70-66F/80-66F** - Two or three 45 kg (99 lb) cast iron plates for a total of 90 or 135 kg (198 or 297 lb).

**BODY**

One-piece, forward-tilting hood.  
Conventional Operator's compartment.  
Partly wrap-around fenders.  
Diesel fuel tank: either in front of radiator (Mods. 45-66V/55-66V/55-66F) or behind Operator's seat (Mods. 60-66F/70-66F/80-66F).  
Operator's seat padded, with parallelogram plus hydraulic damper suspension; adjustable ride and position.  
Dashborad consisting of a multi-function instrument cluster and a controls console.

**ELECTRICAL SYSTEM**

Voltage ..... 12V  
Alternator with integral electronic voltage regulator.  
Makes:  
BOSCH or MARELLI or LUCAS or ISKRA.

Starter motor Makes: MARELLI or BOSCH or LUCAS.  
Battery: located ahead of radiator; capacity ratings (net or dry charge):  
• Mods. 45-66V/55-66V/55-66F/60-66F: 88 Ah  
• Mods. 70-66F/80-66F: 110 Ah  
Alternative batteries: sealed, maintenance-free . . .90 Ah or 110 Ah

**Lighting Equipment**

Two High/asymmetric low beam headlamps, 45-40 W power.  
Two front lights:  
— Parking 5W  
— Turn signal 21W  
Two tail lights:  
— Parking 5W  
— Turn signal 21W  
— Stop 21W  
— License plate

**Instruments and Accessories**

Multi-function instrument cluster.  
Control console.  
Flood (work) light 35W  
Rear power outlet DIN, seven-pole.  
Dash power outlet, Single pole.  
Horn.  
Thermostart.  
Fuses: 8 in all.  
Hazard warning lights for tractor and trailers.

**TIRE SIZES**

	<b>45-66V</b>	<b>55-66V</b>	<b>55-66F</b>	<b>60-66F</b>	<b>70-66F</b>	<b>80-66F</b>
Front . . . . . }	4.00-15 5.00-15	4.00-15 5.00-15	5.00-15 5.00-16 6.00-16	5.50-16 6.00-16 6.50-16	5.50-16 6.00-16 6.50-16	5.50-16 6.00-16 6.50-16
Rear . . . . . }	9.5/ 9-28 11.2/10-24 11.2/10-28	9.5/ 9-28 11.2/10-24 11.2/10-28	11.2/10-28 12.4/11-24 12.4/11-28 13.6/12-24	12.4/11-28 14.9/13-24 13.6/12-28 13.6/12-24 14.9/13-28	12.4/11-28 14.9/13-24 13.6/12-28 13.6/12-24 14.9/13-28	12.4/11-28 14.9/13-24 13.6/12-28 13.6/12-24 14.9/13-28
	<b>45-66DTV</b>	<b>55-66DTV</b>	<b>55-66DTF</b>	<b>60-66DTF</b>	<b>70-66DTF</b>	<b>80-66DTF</b>
Front . . . . . }	6.00-16 (1) 6.00-16 (2) 7.00-12 (3)	6.00-16 (1) 6.00-16 (2) 7.00-12 (3)	6.00-16 (1) 6.50-16 (2) (4) 7.50-16 (3)	7.50-18 (1) (2) 7.50-20 (3) 8.25-16 (4)	7.50-18 (1) (2) 7.50-20 (3) 8.25-16 (4)	7.50-18 (1) (2) 7.50-20 (3) 8.25-16 (4)
Rear . . . . . }	12.4/24 (1) 11.2/28 (2) 12.4/24 (3)	12.4/24 (1) 11.2/28 (2) 12.4/24 (3)	11.2/10-24 (1) 12.4/11-24 (2) 13.6/12-24 (3) 11.2/10-28 (4)	14.9/13-24 (1) 12.4/11-28 (2) 13.6/12-28 (3) 13.6/12-24 (4)	14.9/13-24 (1) 12.4/11-28 (2) 13.6/12-28 (3) 13.6/12-24 (4)	14.9/13-24 (1) 12.4/11-28 (2) 13.6/12-28 (3) 13.6/12-24 (4)

(1) (2) (3) (4). Tire matching references.

## MAIN DIMENSIONS (mm)

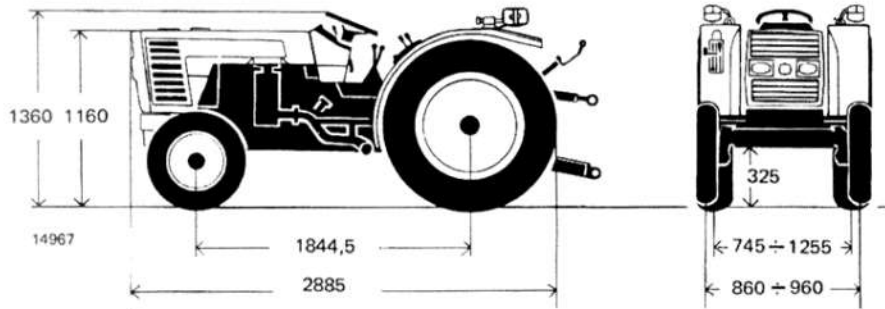

**Mods. 45-66V/55-66V**  
(Tyre sizes: 4.00-15 front  
and 9.5/9-28 rear)

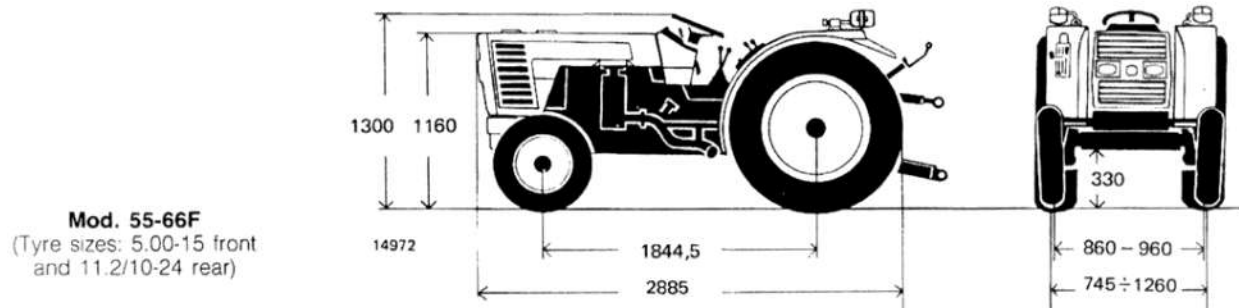

**Mod. 55-66F**  
(Tyre sizes: 5.00-15 front  
and 11.2/10-24 rear)

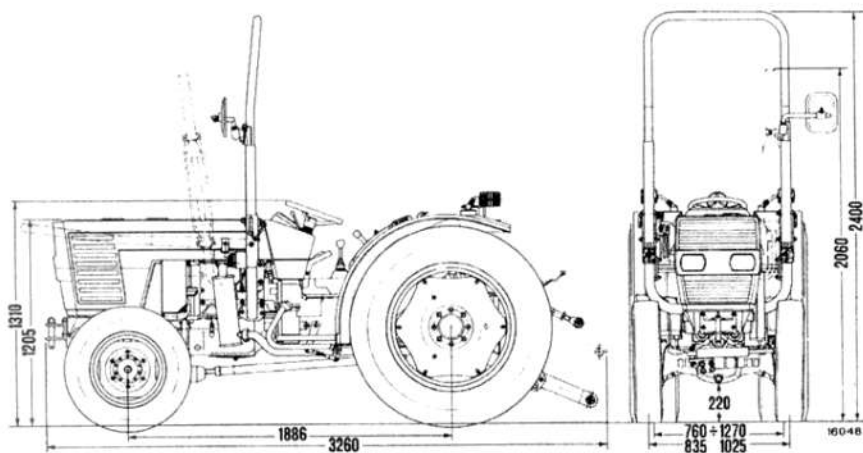

**Mods. 45-66DTV/55-66DTV**  
(Tyre sizes: 6.00-16 front  
and 11.2/28 rear)

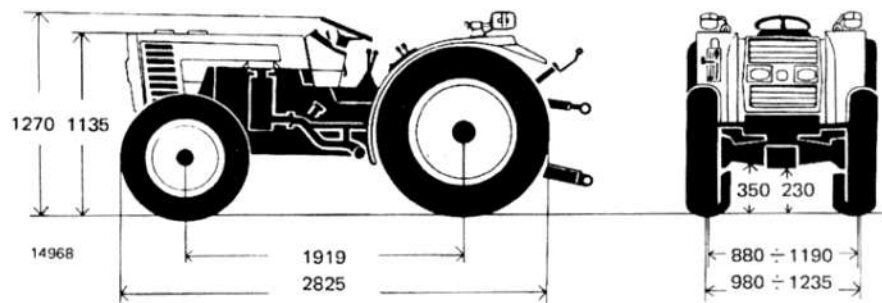

**Mod. 55-66DTF**  
(Tyre sizes: 6.00-16 front  
and 11.2/10-24 rear)

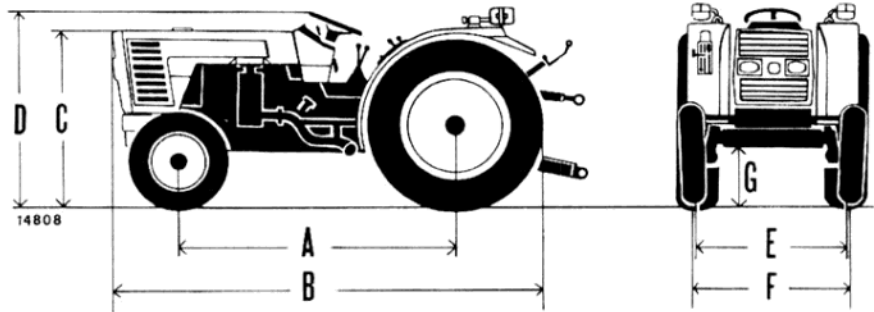

Models	A	B	C	D	E	F	G
<b>66-66F</b> Tyre sizes: 5.50-16 front 12.4/11-28 rear	1886 mm (74 in)	2950 mm (116 in)	1225 mm (48 in)	1360 mm (53.5 in)	1185/1485 mm (46.5/58.5 in)	995/1600 mm (39/63 in)	425 mm (16.7 in)
<b>70-66F</b> Tyre sizes: 6.00-16 front 13.6/12-28 rear	2001 mm (78.8 in)	3090 mm (122 in)	1230 mm (48.5 in)	1365 mm (53.7 in)	1185/1485 mm (47.5/58.5 in)	1000/1510 mm (39.4/59.5 in)	435 mm (17 in)

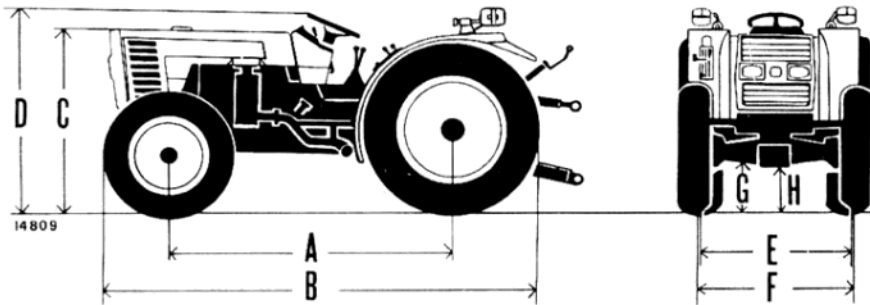

Models	A	B	C	D	E	F	G	H
<b>66-66DTF</b> Tyre sizes: 7.50-18 front 12.4/11-28 rear	1996 mm (78.6 in)	3050 mm (120 in)	1225 mm (48.3 in)	1360 mm (53.5 in)	1100/1275 mm (43/50 in)	995/1600 mm (39/63 in)	425 mm (16.7 in)	280 mm (11 in)
<b>70-66DTF</b> Tyre sizes: 7.50-20 front 13.6/12-28 rear	2111 mm (83 in)	3210 mm (126 in)	1245 mm (49 in)	1380 mm (54 in)	1220/1420 mm (48/56 in)	1000/1510 mm (39.4/59.5 in)	435 mm (17 in)	300 mm (11.8 in)

POWER TRAIN SCHEMATICS

Mod. 55-66 DTF  
with creeper

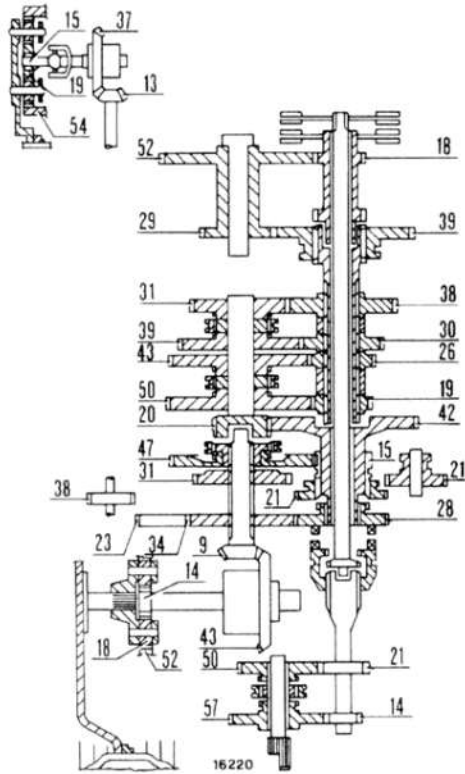

Mods. 60-66DTF/70-66DTF/80-66DTF  
with creeper

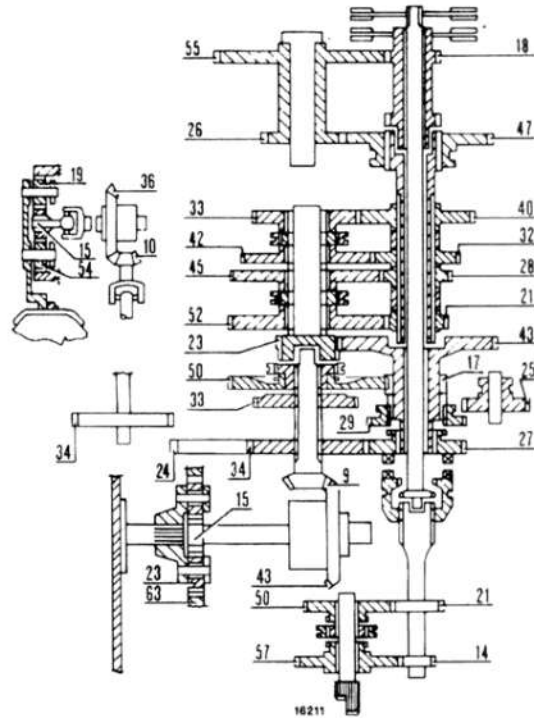

Tractor road speeds, engine at max power RPM and rear wheel tyres as indicated

GEARS	Mods. 45-66V/55-66V						Mod. 55-66F						Mods. 60-66F/70-66F/80-66F													
	9.5/9-28		11.2/10-24		11.2/10-28		11.2/10-24		11.2/10-28		12.4/11-24		13.6/12-24		12.4/11-28		13.6/12-24		12.4/11-28 14.9/13-24		13.6/12-28		14.9/13-28			
	mph	kph	mph	kph	mph	kph	mph	kph	mph	kph	mph	kph	mph	kph	mph	kph	mph	kph	mph	kph	mph	kph	mph	kph	mph	kph
1st creeper low	0.25	0.4	0.2	0.3	0.25	0.4	0.2	0.3	0.25	0.4	0.25	0.4	0.25	0.4	0.2	0.3	0.2	0.3	0.2	0.3	0.2	0.3	0.2	0.3	0.2	0.3
2nd creeper low	0.3	0.5	0.3	0.5	0.3	0.5	0.3	0.5	0.3	0.5	0.3	0.5	0.3	0.5	0.4	0.6	0.25	0.4	0.3	0.5	0.3	0.5	0.3	0.5	0.3	0.5
3rd creeper low	0.45	0.7	0.4	0.6	0.45	0.7	0.4	0.6	0.45	0.7	0.45	0.7	0.45	0.7	0.3	0.5	0.4	0.6	0.4	0.6	0.4	0.6	0.4	0.6	0.4	0.6
4th creeper low	0.7	1.1	0.6	1.0	0.7	1.1	0.6	1.0	0.7	1.1	0.7	1.1	0.7	1.1	0.7	1.1	0.5	0.9	0.5	0.9	0.6	1.0	0.6	1.0	0.6	1.0
1st creeper norm	0.55	0.9	0.5	0.8	0.55	0.9	0.5	0.8	0.55	0.9	0.55	0.9	0.55	0.9	0.55	0.9	0.4	0.6	0.45	0.7	0.45	0.7	0.45	0.7	0.45	0.7
2nd creeper norm	0.9	1.4	0.8	1.3	0.9	1.4	0.8	1.3	0.9	1.4	0.9	1.4	0.9	1.4	0.95	1.5	0.6	1.0	0.7	1.1	0.7	1.1	0.7	1.1	0.7	1.1
3rd creeper norm	1.1	1.8	1.0	1.7	1.1	1.8	1.0	1.7	1.1	1.8	1.0	1.7	1.1	1.8	1.2	1.9	0.7	1.2	0.8	1.3	0.9	1.4	0.9	1.4	0.9	1.4
4th creeper norm	1.7	2.8	1.6	2.6	1.8	2.9	1.6	2.6	1.8	2.9	1.7	2.8	1.6	2.9	1.9	3.0	1.2	2.0	1.3	2.1	1.4	2.2	1.4	2.2	1.4	2.2
1st low	0.8	1.3	0.7	1.2	0.8	1.3	0.7	1.2	0.8	1.3	0.8	1.3	0.8	1.3	0.9	1.4	0.9	1.5	1.0	1.6	1.1	1.7	1.1	1.7	1.1	1.8
2nd low	1.3	2.1	1.2	2.0	1.4	2.2	1.2	2.0	1.4	2.2	1.3	2.1	1.3	2.1	1.4	2.3	1.4	2.4	1.5	2.5	1.6	2.6	1.7	2.7	1.7	2.7
3rd low	1.7	2.7	1.5	2.5	1.7	2.7	1.5	2.5	1.7	2.7	1.6	2.6	1.7	2.7	1.8	2.9	1.8	2.9	1.9	3.1	2.0	3.2	2.1	3.3	2.1	3.3
4th low	2.6	4.2	2.5	4.0	2.7	4.4	2.5	4.0	2.7	4.4	2.6	4.2	2.7	4.3	2.9	4.6	2.9	4.7	3.0	4.9	3.1	5.1	3.1	5.3	3.1	5.3
1st normal	2.1	3.4	2.0	3.2	2.2	3.5	2.0	3.2	2.2	3.5	2.1	3.4	2.2	3.5	2.35	3.7	2.3	3.6	2.4	3.8	2.5	4.0	2.6	4.2	2.6	4.2
2nd normal	3.35	5.4	3.2	5.1	3.5	5.6	3.2	5.1	3.5	5.6	3.3	5.3	3.4	5.5	3.45	5.8	3.5	5.6	3.7	5.9	3.8	6.2	4.0	6.4	4.0	6.4
3rd normal	4.3	6.9	4.0	6.5	4.4	7.1	4.0	6.5	4.4	7.1	4.2	6.8	4.4	7.1	4.65	7.5	4.3	6.9	4.45	7.2	4.6	7.5	4.8	7.8	4.8	7.8
4th normal	6.8	11.0	6.4	10.3	7.0	11.3	6.4	10.3	7.0	11.3	6.7	10.8	6.9	11.2	7.3	11.8	6.8	10.9	7.1	11.5	7.5	12.0	7.7	12.5	7.7	12.5
1st high	5.4	8.7	5.1	8.2	5.6	9.0	5.1	8.2	5.6	9.0	5.3	8.6	5.5	8.9	5.8	9.4	5.3	8.6	5.6	9.0	5.8	9.4	6.0	9.8	6.0	9.8
2nd high	8.6	13.8	8.0	13.0	8.9	14.3	8.0	13.0	8.9	14.3	8.5	13.7	8.8	14.2	9.3	14.9	8.2	13.2	8.6	13.9	9.0	14.5	9.4	15.1	9.4	15.1
3rd high	10.9	17.5	10.3	16.6	11.3	18.2	10.3	16.6	11.3	18.2	10.8	17.4	11.2	18.0	11.8	19.0	10.0	16.2	10.6	17.0	11.0	17.8	11.5	18.5	11.5	18.5
4th high	17.3	27.9	16.4	26.4	18.0	29.0	16.4	26.4	18.0	29.0	17.2	27.7	17.8	28.7	18.8	30.3	15.9	25.7	16.8	27.1	17.3	28.3	18.3	29.4	18.3	29.4
1st low reverse	0.55	0.9	0.55	0.9	0.55	0.9	0.55	0.9	0.55	0.9	0.55	0.9	0.55	0.9	0.6	1.0	0.45	0.7	0.5	0.8	0.5	0.8	0.5	0.8	0.5	0.8
2nd low reverse	0.95	1.5	0.9	1.4	0.95	1.5	0.9	1.4	0.95	1.5	0.9	1.4	0.95	1.5	1.0	1.6	0.7	1.1	0.7	1.2	0.7	1.2	0.8	1.3	0.8	1.3
3rd low reverse	1.2	1.9	1.0	1.7	1.2	1.9	1.0	1.7	1.2	1.9	1.1	1.8	1.2	1.9	1.2	1.9	0.9	1.4	0.9	1.4	0.95	1.5	1.0	1.6	1.0	1.6
4th low reverse	1.9	3.0	1.7	2.8	1.9	3.1	1.7	2.8	1.9	3.1	1.8	2.9	1.9	3.1	2.0	3.2	1.4	2.2	1.4	2.3	1.4	2.4	1.5	2.5	1.5	2.5
1st high reverse	2.3	3.6	2.1	3.4	2.35	3.7	2.1	3.4	2.35	3.7	2.2	3.5	2.35	3.7	2.4	3.9	2.5	4.0	2.6	4.2	2.7	4.4	2.75	4.3	2.75	4.3
2nd high reverse	3.5	5.7	3.35	5.4	3.7	5.9	3.35	5.4	3.7	5.9	3.5	5.7	3.7	5.9	3.8	6.2	3.8	6.2	4.0	6.5	4.2	6.8	4.4	7.1	4.4	7.1
3rd high reverse	4.5	7.3	4.3	6.9	4.65	7.5	4.3	6.9	4.65	7.5	4.45	7.2	4.65	7.5	4.9	7.9	4.7	7.6	4.9	8.0	5.2	8.4	5.4	8.7	5.4	8.7
4th high reverse	7.2	11.6	6.8	11.0	7.5	12.0	6.8	11.0	7.5	12.0	7.1	11.5	7.4	11.9	7.8	12.6	7.5	12.1	7.9	12.7	8.2	13.3	8.6	13.8	8.6	13.8

**POWER TRAIN SCHEMATICS**

**Mods. 45-66DTV/55-66DTV  
with mechanical reverser**

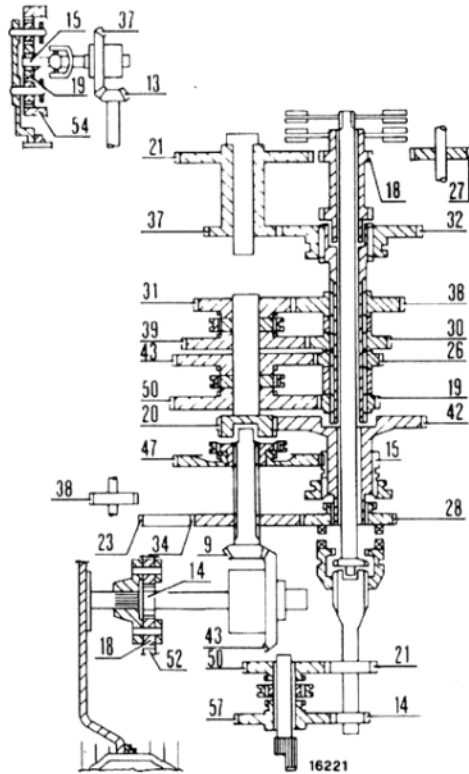

**Mods. 60-66DTF/70-66DTF/80-66DTF  
with mechanical reverser**

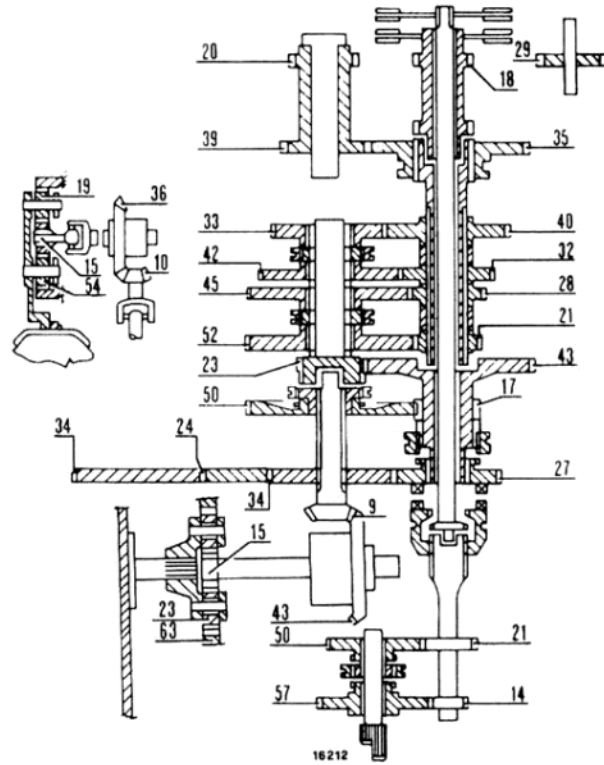

**Tractor road speeds, engine at max power RPM and rear wheel tyres as indicated -**

FORWARD GEARS	Mods. 45-66V/55-66V						Mod. 55-66F						Mods. 60-66F/70-66F/80-66F									
	9.5/9-28		11.2/10-24		11.2/10-28		11.2/10-24		11.2/10-28		12.4/11-24		13.6/12-24		13.6/12-24		12.4/11-28 14.9/13-24		13.6/12-28		14.9/13-28	
	mph	kph	mph	kph	mph	kph	mph	kph	mph	kph	mph	kph	mph	kph	mph	kph	mph	kph	mph	kph	mph	kph
1st low	0.8	1.3	0.7	1.2	0.8	1.3	0.7	1.2	0.8	1.3	0.8	1.3	0.8	1.3	0.9	1.5	1.0	1.6	1.1	1.7	1.1	1.8
2nd low	1.3	2.1	1.2	2.0	1.4	2.2	1.2	2.0	1.4	2.2	1.3	2.1	1.3	2.1	1.4	2.4	1.5	2.5	1.6	2.6	1.7	2.7
3rd low	1.7	2.7	1.5	2.5	1.7	2.7	1.5	2.5	1.7	2.7	1.6	2.6	1.7	2.7	1.8	2.9	1.9	3.1	2.0	3.2	2.1	3.3
4th low	2.6	4.2	2.5	4.0	2.7	4.4	2.5	4.0	2.7	4.4	2.6	4.2	2.7	4.3	2.9	4.7	3.0	4.9	3.1	5.1	3.3	5.3
1st normal	2.1	3.4	2.0	3.2	2.2	3.5	2.0	3.2	2.2	3.5	2.1	3.4	2.2	3.5	2.3	3.6	2.4	3.8	2.5	4.0	2.6	4.2
2nd normal	3.4	5.4	3.1	5.1	3.5	5.6	3.1	5.1	3.5	5.6	3.3	5.3	3.4	5.5	3.5	5.6	3.7	5.9	3.8	5.2	4.0	6.4
3rd normal	4.3	6.9	4.0	6.5	4.4	7.1	4.0	6.5	4.4	7.1	4.2	6.8	4.4	7.1	4.3	6.9	4.5	7.2	4.7	7.5	4.8	7.8
4th normal	6.8	10.9	6.4	10.3	7.0	11.3	6.4	10.3	7.0	11.3	6.7	10.8	6.9	11.2	6.8	10.9	7.1	11.5	7.5	12.0	7.7	12.5
1st high	5.4	8.7	5.1	8.2	5.6	9.0	5.1	8.2	5.6	9.0	5.3	8.6	5.5	8.9	5.3	8.6	5.6	9.0	5.8	9.4	6.0	9.8
2nd high	8.6	13.9	8.0	13.0	8.9	14.3	8.0	13.0	8.9	14.3	8.5	13.7	8.8	14.2	8.2	13.2	8.6	13.9	9.0	14.5	9.4	15.1
3rd high	10.9	17.5	10.3	16.6	11.3	18.2	10.3	16.6	11.3	18.2	10.8	17.4	11.2	18.0	10.0	16.2	10.6	17.0	11.0	17.3	11.5	18.5
4th high	17.3	27.9	16.4	26.4	18.0	29.0	16.4	26.4	18.0	29.0	17.2	27.7	17.8	28.7	15.9	25.7	16.8	27.1	17.6	28.3	18.3	29.4
REVERSE GEARS	mph	kph	mph	kph	mph	kph	mph	kph	mph	kph	mph	kph	mph	kph	mph	kph	mph	kph	mph	kph	mph	kph
1st low	0.8	1.3	0.7	1.2	0.8	1.3	0.7	1.2	0.8	1.3	0.8	1.3	0.8	1.3	1.0	1.6	1.0	1.6	1.1	1.7	1.1	1.8
2nd low	1.3	2.1	1.2	1.9	1.3	2.1	1.2	1.9	1.3	2.1	1.2	2.0	1.3	2.1	1.4	2.4	1.5	2.5	1.6	2.6	1.7	2.7
3rd low	1.6	2.6	1.5	2.5	1.7	2.7	1.5	2.5	1.7	2.7	1.6	2.6	1.7	2.7	1.8	2.9	1.9	3.1	2.0	3.2	2.1	3.4
4th low	2.6	4.2	2.5	4.0	2.7	4.3	2.5	4.0	2.7	4.3	2.6	4.2	2.7	4.3	2.9	4.7	3.0	4.9	3.2	5.2	3.4	5.4
1st normal	2.1	3.4	2.0	3.2	2.2	3.5	2.0	3.2	2.2	3.5	2.1	3.3	2.1	3.4	2.3	3.6	2.4	3.8	2.5	4.0	2.6	4.2
2nd normal	3.3	5.3	3.1	5.0	3.4	5.5	3.1	5.0	3.4	5.5	3.3	5.3	3.4	5.5	3.5	5.6	3.7	5.9	3.8	6.2	4.0	6.4
3rd normal	4.2	6.8	4.0	6.4	4.3	7.0	4.0	6.4	4.3	7.0	4.1	6.7	4.3	7.0	4.3	7.0	4.5	7.3	4.7	7.6	4.9	7.9
4th normal	6.8	10.9	6.4	10.3	6.9	11.2	6.4	10.3	6.9	11.2	6.7	10.8	6.9	11.1	6.8	10.9	7.2	11.6	7.5	12.0	7.7	12.5
1st high	5.3	8.6	5.0	8.1	5.5	8.9	5.0	8.1	5.5	8.9	5.3	8.5	5.5	8.8	5.3	8.6	5.6	9.0	5.8	9.4	6.0	9.8
2nd high	8.4	13.6	8.0	12.9	8.7	14.1	8.0	12.9	8.7	14.1	8.4	13.5	8.7	14.0	8.2	13.2	8.6	13.9	9.0	14.5	9.4	15.1
3rd high	10.8	17.4	10.2	16.4	11.2	18.0	10.2	16.4	11.2	18.0	10.7	17.2	11.0	17.8	10.0	16.2	10.6	17.1	11.0	17.3	11.5	18.5
4th high	17.2	27.7	16.3	26.2	17.8	28.7	16.3	26.2	17.8	28.7	17.0	27.4	17.6	28.4	16.0	25.8	16.9	27.2	17.6	28.3	18.4	29.5

## SPECIFICATIONS

## FLUID CAPACITIES

DESCRIPTION	RECOMMENDED FIAT PRODUCT	CAPACITY												INTERNATIONAL DESIGNATION
		45-66V/55-66V/55-66F				60-66F				70-66F/80-66F				
		dm <sup>3</sup> (litr)	Imp. Gals	kg	Imp. Gals	dm <sup>3</sup> (litr)	Imp. Gals	kg	dm <sup>3</sup> (litr)	Imp. Gals	kg	dm <sup>3</sup> (litr)	Imp. Gals	
Cooling system	Water and FIAT <b>PARAFLU 11*</b>	12	2 $\frac{2}{3}$	—	2 $\frac{2}{3}$	12	—	—	14	3	—	—	—	
Fuel tank	Decanted and filtered diesel fuel	50	11	—	11	50	—	—	50	11	—	—	—	
Sump and filter	<b>oliofiat AMBRA SUPER</b>	7,3	1 $\frac{2}{3}$	6,6	1 $\frac{2}{3}$	7,3	1 $\frac{2}{3}$	6,6	11,7	2 $\frac{2}{4}$	10,5	2 $\frac{2}{3}$	10,5	
Sump only		6,7	1 $\frac{1}{2}$	6,0	1 $\frac{1}{2}$	6,7	1 $\frac{1}{2}$	6,0	10,5	2 $\frac{1}{3}$	9,5	2 $\frac{1}{3}$	9,5	
Power steering system	<b>oliofiat TUTELA MULTI F</b>	—	Imp. Pts	—	Imp. Pts	—	Imp. Pts	—	—	—	—	—	—	
Live front axle		1,7	3	1,5	3 $\frac{2}{3}$	1,9	3 $\frac{2}{3}$	1,7	1,9	3 $\frac{2}{3}$	1,7	3 $\frac{2}{3}$	1,7	
4WD models (each)		3,9 <sup>(1)</sup>	6 $\frac{4}{5}$	3,5 <sup>(1)</sup>	7 $\frac{1}{5}$	4,1	7 $\frac{1}{5}$	3,7	4,1	7 $\frac{1}{5}$	3,7	7 $\frac{1}{5}$	3,7	
Rear drive housing (transm., bevel gear, side final drives and brakes) plus lift:	<b>oliofiat TUTELA MULTI F</b>	1,2 <sup>(1)</sup>	2	1,1 <sup>(2)</sup>	2	1,2	2	1,1	1,2	2	1,1	2	1,1	
— 2 WD		—	Imp. Gals	—	Imp. Gals	—	Imp. Gals	—	—	—	—	—	—	
— 4 WD	24,4	5 $\frac{1}{3}$	22	9 $\frac{1}{3}$	42,2	9 $\frac{1}{3}$	38	42,2	9 $\frac{1}{3}$	38	42,2	9 $\frac{1}{3}$	38	
Front wheel hubs	<b>grassofiat TUTELA G9</b>	25	5 $\frac{1}{2}$	22,5	9 $\frac{1}{3}$	42,7	9 $\frac{1}{3}$	38,5	42,7	9 $\frac{1}{3}$	38,5	42,7	9 $\frac{1}{3}$	
Grease fittings		—	—	—	—	—	—	—	—	—	—	—	—	—

<sup>(1)</sup> Indicated quantity applies to mod. 55-66DTF only. For mods. 45-66DTV/55-66DTV the quantity of **TUTELA MULTI F** required is 5.5 dm<sup>3</sup> — 5 kg or 1  $\frac{1}{5}$  u.s. Gals

<sup>(2)</sup> Indicated quantity applies to mod. 55-66DTF only. Front axle epicyclic side final drives on mods. 45-66DTV/55-66DTV need no oil but, during servicing, shall be packed with **TUTELA G9 grease** as instructed in the applicable Section.

**POWER TRAIN**

	<b>45-66V/55-66V/55-66F</b>	<b>60-66F/70-66F/80-66F</b>
<b>Clutches</b> LUK 10"/10" or VALEO 10"/10" . . . . .	See page 1, Sect. 20, mod. 45-66	—
<b>Clutches</b> LUK 11"/11" or VALEO 11"/11" or OMG 11"/11" . . . . .	—	See page 1 and 2, Sect. 20 Mods. 55-66LP/60-66LP/70-66LP
<b>Transmission and splitter</b> . . . . .	See pages 1 and 2, Mod. 45-66	See page 2, Sect. 20 Mods. 55-66/60-66/70-66/80-66
<b>Creep</b> . . . . .	See page 2, Sect. 20, Mod. 45-66	See page 4, Sect. 20, Mods. 466/566/666/766
<b>Reverser</b> . . . . .	—	See page 4, Sect. 20, Mods. 466/566/666/766
<b>Rear bevel drive and differential</b> . . . . .	See page 3, Sect. 20 Mod. 45-66	See page 2, Sect. 20, Mods. 55-66/60-66/70-66/80-66
<b>Brakes</b> . . . . .	See page 3, Sect. 20, Mod. 45-66	See pages 5 and 6, Sect. 20, Mods. 466/566
<b>Parking brake on drive train</b> . . . . .	—	—
<b>Side final drives</b> — Type . . . . . — Reduction ratios . . . . . — Planet carrier adjusting ring thickness range . . . mm . . . . . in	Epicyclic, 3-planets, straight spur gears 14 to (14+52) = 1 to 4.7   15 to (15+63) = 1 to 5.2 3.5-3.6-3.7-3.8-3.9-4.0-4.1-4.2-4.3-4.4-4.5-4.6-4.7-4.8 0.138-0.142-0.146-0.150-0.154-0.158-0.162-0.166-0.170-0.174- 0.178-0.182-0.186-0.190	
<b>Power Take Off</b> . . . . .  Ground speed PTO rotation: — 540 RPM . . . . . revs/wheel turn — 1000 RPM . . . . . revs/wheel turn	See page 4, Sect. 20, Mod. 45-66 except as follows:  6.7 11.5	See page 3, Sect. 20, Mods. 55-66/60-66/70-66/80-66 except as follows:  7.7 13.1

**TORQUE DATA: MODELS 60-66F/70-66F/80-66F**

Refer to page 2, Sect. 20, Mods. 55-66LP/60-66LP/70-66LP.

**TORQUE DATA: MODELS 45-66V/55-66V/55-66F**

Refer to page 5, Sect. 20, Mod. 45-66 except for items listed below.

ITEM	Thread size	Torque		
		Nm	kgm	ft lb
<b>Side Final Drives - Sect. 206</b>				
Nuts, final drive case studs (C <sub>1</sub> , p. 1) . . . . .	M10x1.25	73	7.5	54.2
Screw, driving wheel shaft (C <sub>2</sub> ) . . . . .	M18x1.5	250	25.5	197

# POWER TRAIN: Specifications and data

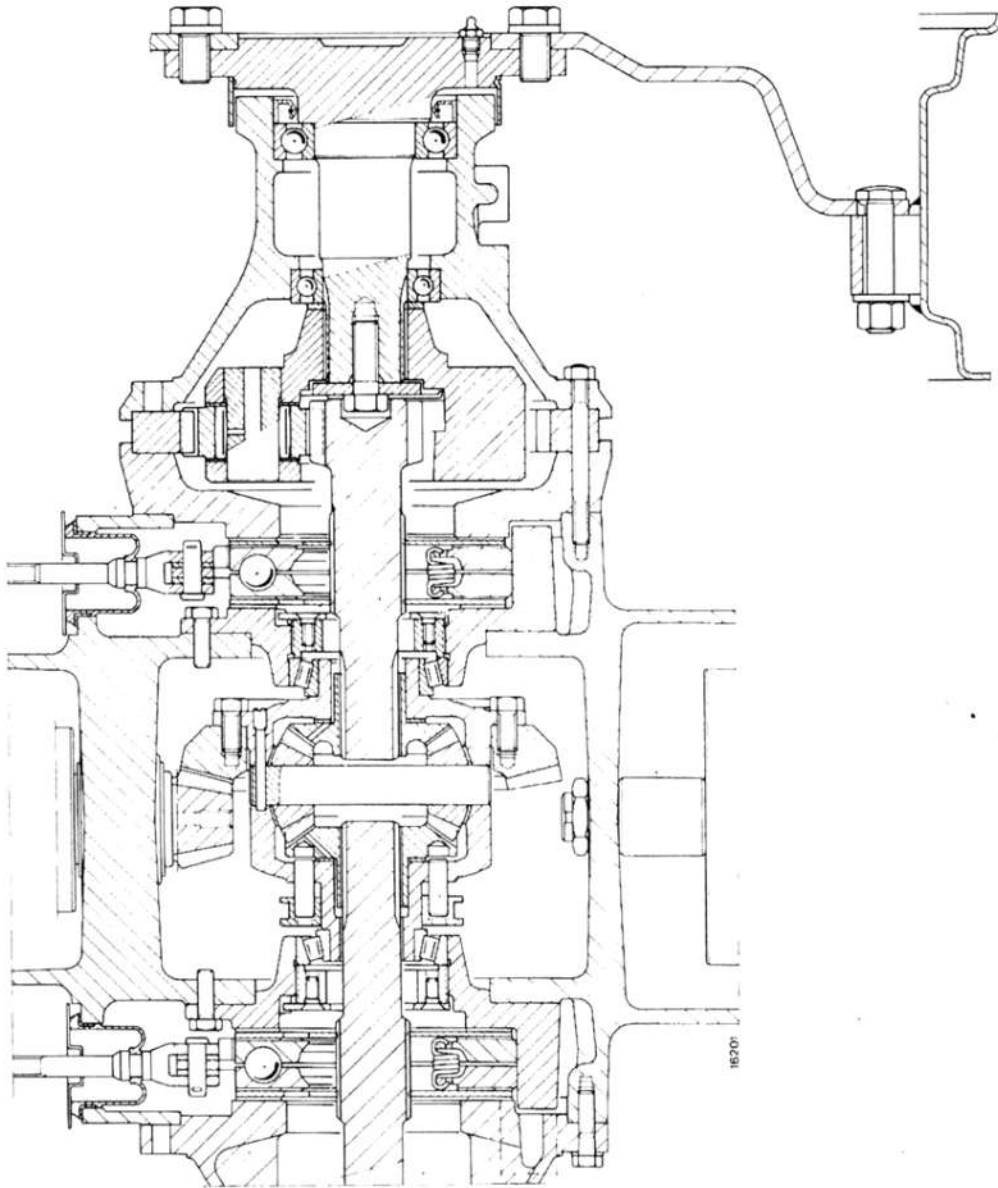

Power train cross section - Mods. 45-66V/55-66V/55-66F



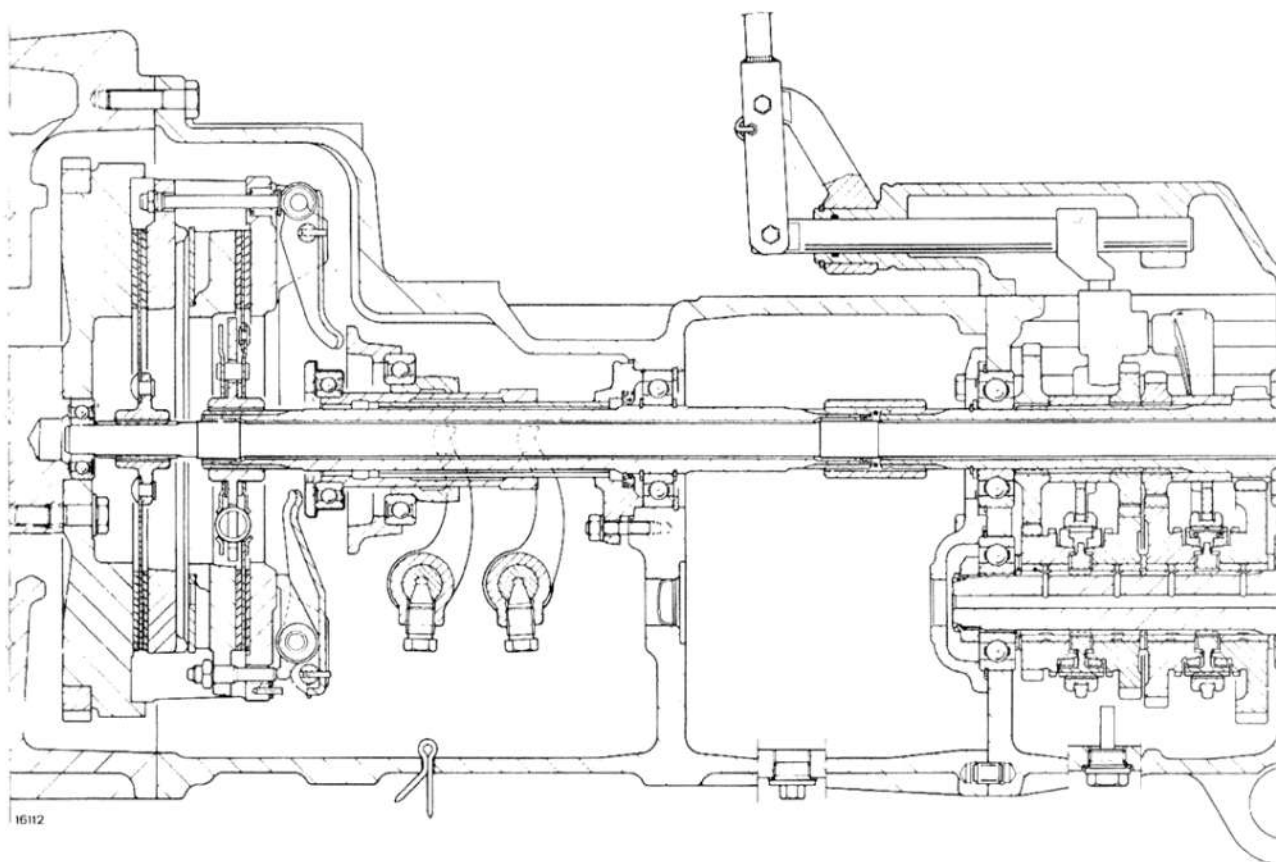

Power train longitudinal section - Mods. 45-66V/55-66V/55-66F

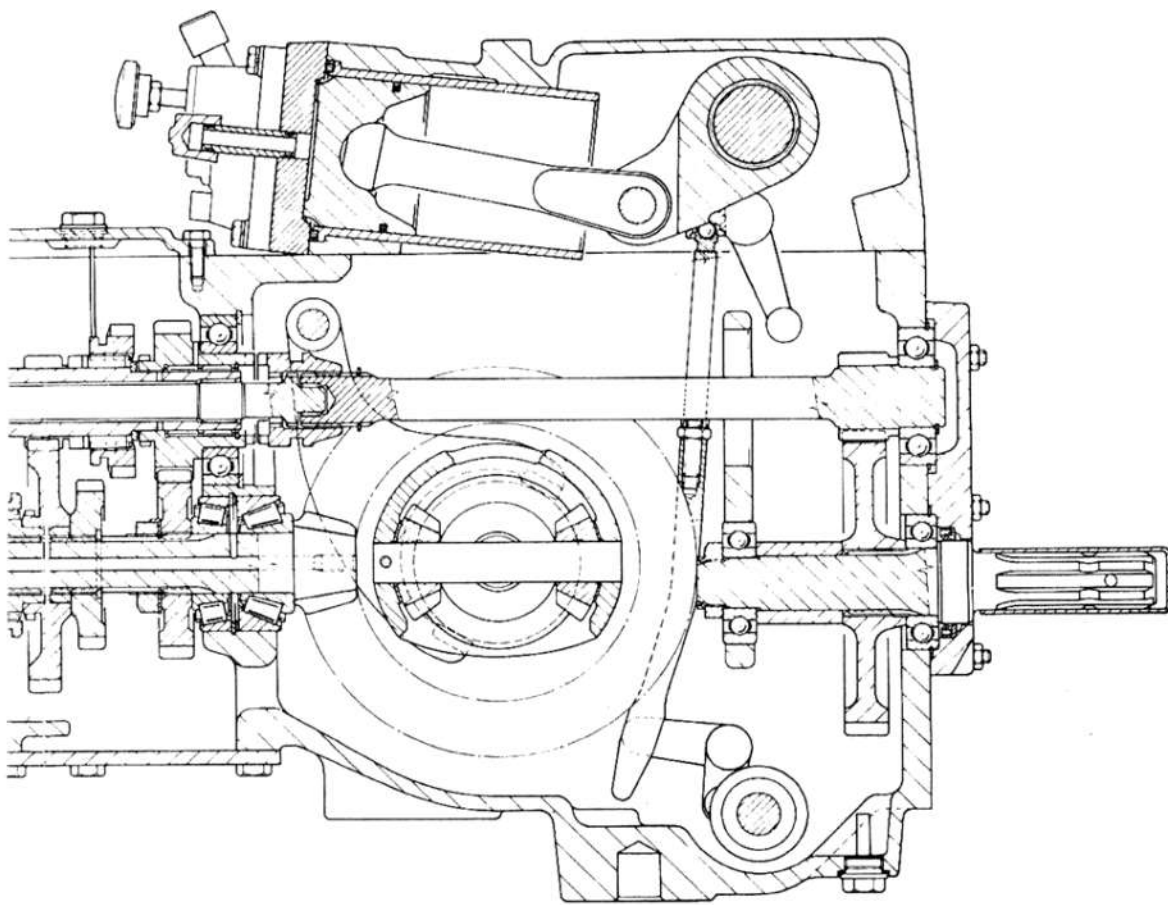

# POWER TRAIN: Specifications and Data

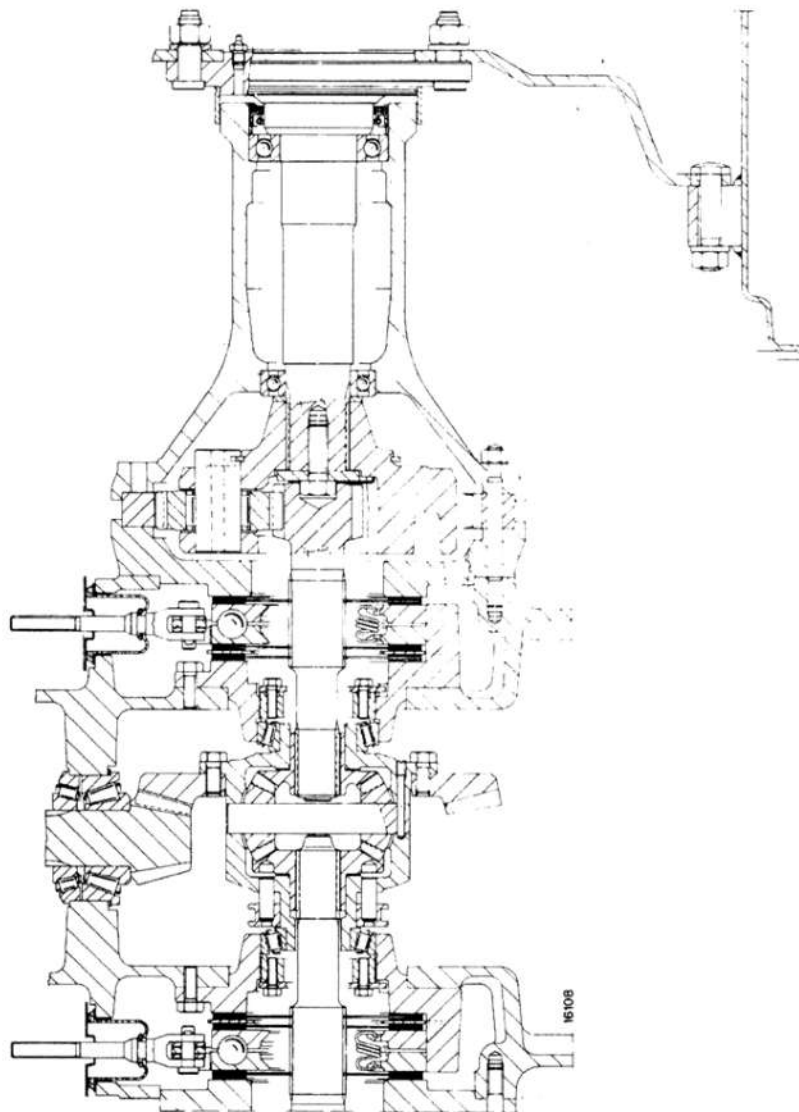

Power train cross section - Mods. 60-66F/70-66F/80-66F

**SERVICING - VALEO 10''/10'' CLUTCH  
(Mods. 45-66V/55-66V/55-66F)**

Refer to the descriptions and illustrations on pages 2, 3, 4 and 5, Sect. 201, Model 45-66.

**ADJUSTMENT - VALEO 10''/10'' CLUTCH  
(Mods. 45-66V/55-66V/55-66F)**

Refer to the descriptions and illustrations on pages 5 and 6, Sect. 201, Mods. 45-66.

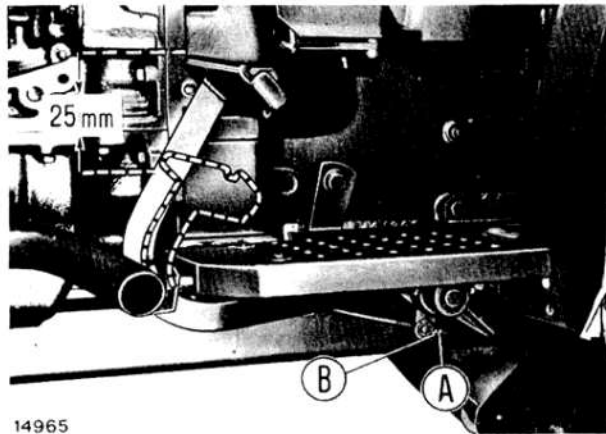

**Transmission clutch pedal free travel adjustment (Mods. 45-66V/55-66V/55-66F).**

A. Jam nut - B. Adjusting nut.

**TRANSMISSION CLUTCH CONTROL LINKAGE ADJUSTMENT (Mods. 45-66V/55-66V/55-66F)**

Check that clutch pedal free travel is approximately 25 mm (1 in) before clutch releases. Once it reduces to 15 mm (0.6 in) adjust clutch as follows:

- Unlock jam nut (A) and screw in nut (B) (Each full turn of nut B is equivalent to about 12 mm (1/2 in) pedal travel displacement).
- Lock jam nut (A).
- Make sure pedal free travel is now 25 mm (1.0 in) as specified.

**PTO CLUTCH CONTROL LINKAGE ADJUSTMENT (Mods. 45-66V/55-66V/55-66F)**

Shift lever (C) in rest position (all down) then check that lever free travel - at pin (D) - is 4.5 mm (0.18 in) before clutch begins to release.

Once lever free travel is reduced to 2.5 mm (0.10 in) adjust as follows:

**SERVICING - LUK 10''/10'' CLUTCH  
(Mods. 45-66V/55-66V/55-66F)**

Refer to the descriptions and illustrations on pages 6, 7 and 8, Sect. 201, for Mod. 45-66.

**ADJUSTMENT - LUK 10''/10'' CLUTCH  
(Mods. 45-66V/55-66V/55-66F)**

Refer to the descriptions and illustrations on pages 8 and 9, Sect. 201, for Mod. 45-66).

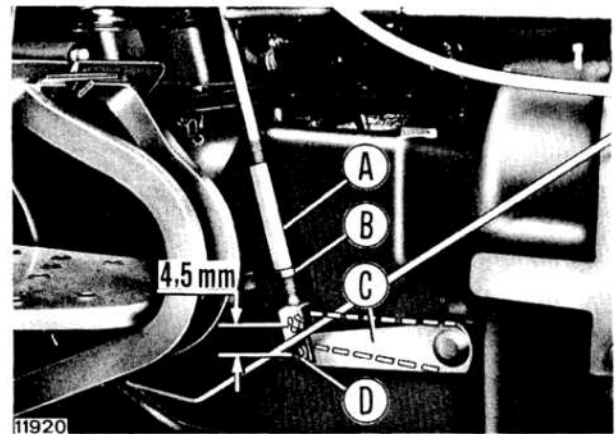

**PTO clutch control hand lever free travel adjustment (Mods. 46-55V/55-66V/55-66F).**

A. Adjuster sleeve - B. Jam nut - C. Idle lever - D. Pin.

- Unlock jam nut (B) and turn sleeve (A) clockwise about 3/4 turn (at every full turn pin (D) shifts 3 mm - 0.12 in).
- Lock jam nut (B).
- Make sure lever free travel is 4.5 mm (0.18 in).

**SERVICING - VALEO 11''/11'' CLUTCH (Mods. 60-66F/70-66F/80-66F)**

Refer to the descriptions and illustrations on pages 1 thru 4, Sect. 201, for Mods. 55-66/60-66/70-66/80-66.

**ADJUSTMENT - VALEO 11''/11'' CLUTCH (Mods. 60-66F/70-66F/80-66F)**

Refer to the descriptions and illustrations on pages 4, 5 and 6, for Mods. 55-66/60-66/70-66/80-66.

**SERVICING - LUK 11''/11'' OR O.M.G. 11''/11'' CLUTCHES (Mods. 60-66/70-66F/80-66F)**

Refer to the descriptions and illustrations on pages 6 thru 9, Sect. 201 for Mods. 466/566/666/766.

**Note** - The LUK 11''/11'' and O.M.G. 11''/11'' clutch

## POWER TRAIN: Clutch

sections shown on page 5, Sect. 201 in Mods. 55-66/60-66/70-66/80-66 Manual replace their counterparts shown on page 8, Sect. 201 in Mods. 466/566/666/766 Manual.

### ADJUSTMENT - LUK 11"/11" OR O.M.G. 11"/11" CLUTCHES (Mods. 60-66F/70-66F/80-66F)

Refer to the descriptions and illustrations on pages 10 and 11, Sect. 201, in Mods. 466/566/666/766 Manual.

### TRANSMISSION CLUTCH CONTROL LINKAGE ADJUSTMENT (Mods. 60-66F/70-66F/80-66F)

Check that clutch pedal free travel is approximately 25 mm (1 in) before clutch releases. Once it reduces to 15 mm (0.6 in) adjust clutch as follows:

- Unlock jam nut (A) and screw in nut (B). (Each full turn of nut B is equivalent to 12 mm (1/2 in) pedal travel displacement).

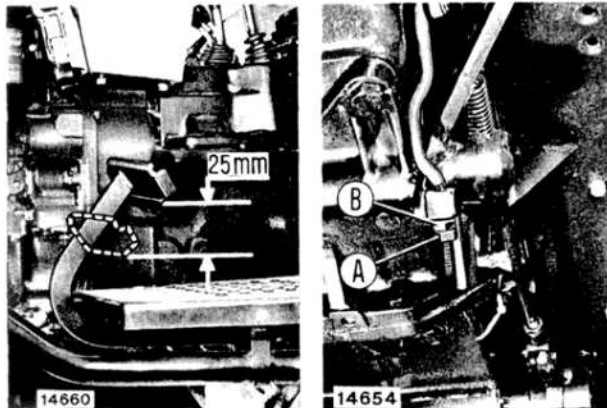

Transmission clutch pedal free travel adjustment (Mods. 60-66F/70-66F/80-66F).

A. Jam nut - B. Adjusting nut.

- Lock jam nut (A).
- Make sure pedal free travel is now 25 mm (1 in) as specified.

### PTO CLUTCH CONTROL LINKAGE ADJUSTMENT (Mods. 60-66F/70-66F/80-66F)

Shift lever (C) in rest position (all down) then check that lever free travel - at pin (D) - is 4.5 mm (0.18 in) before clutch begins to release.

Once lever free travel is reduced to 2.5 mm (0.10 in) adjust as follows:

- Unlock jam nut (B) and turn sleeve (A) clockwise about 3/4 turn (at every full turn pin D shifts 3 mm - 0.12 in).
- Make sure lever free travel is 4.5 mm (0.18 in).

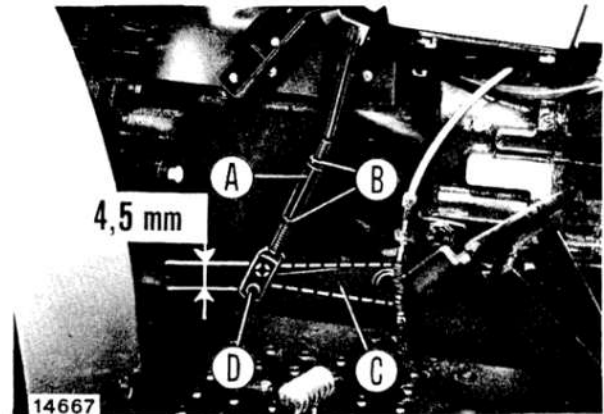

PTO clutch control hand lever free travel adjustment (Mods. 60-66F/70-66F/80-66F).

A. Adjuster sleeve - B. Jam nuts - C. Idle lever - D. Pin.

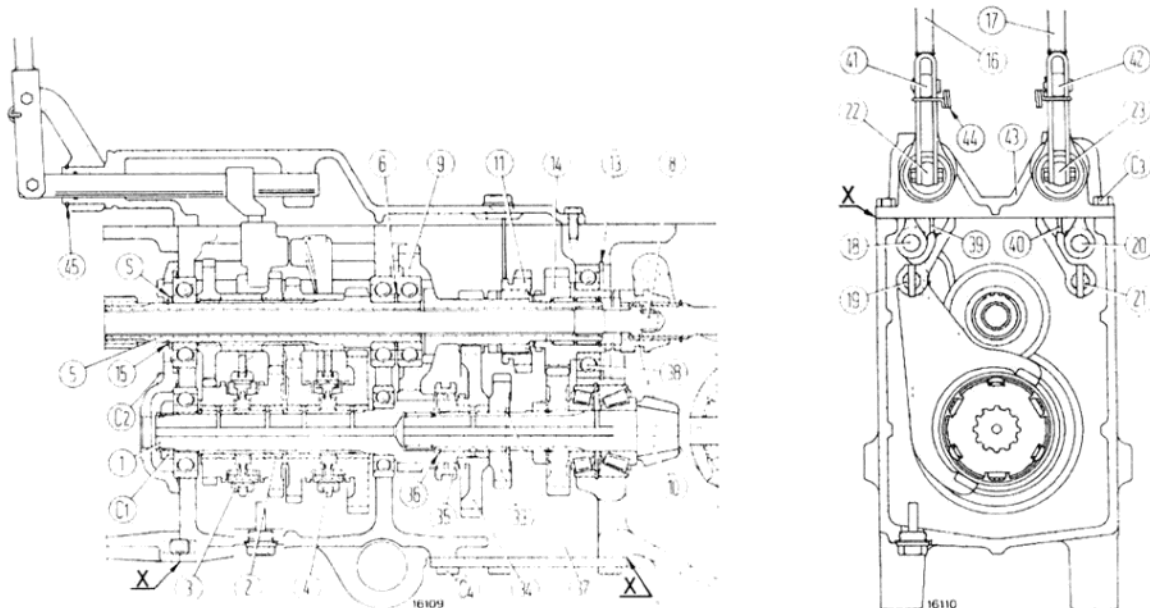

**Longitudinal and cross sections through transmission and splitter - Mods. 45-66V/55-66V/55-66F.**

C1. Driven gear drive shaft lock nut - C2. Bearing cover retaining screws - C3. Top cover retaining screws - C4. Bottom cover retaining screws - S. Drive shaft bearing shim - 1. Transmission driven shaft - 2. Transmission driven gear support bushings - 3. 3rd/4th sliding sleeve - 4. 1st/2nd sliding sleeve - 5. Transmission drive shaft - 6. Washer - 8. PTO shaft - 9. Direct drive and low range drive shaft - 10. Bevel drive pinion shaft - 11. Reverse and Normal range sliding gear - 13. - 15. - 36. - 45. Retaining rings - 14. Normal range drive gear - 16. Transmission shift lever - 17. Splitter shift lever - 18. 1st/2nd speed striker rod - 19. 3rd/4th striker rod - 20. Low/High range striker rod - 21. Normal/Reverse range striker rod - 22. Transmission shift control horizontal relay bar. - 23. Splitter shift control horizontal relay bar - 33. Reverse gear - 34. Low range driven gear - 35. Low range/Direct drive sliding sleeve - 37. Rings - 38. Bearings - 39. Transmission shift plunger - 40. Splitter shift plunger - 41. Transmission shift lever fulcrum support - 42. Splitter shift lever fulcrum support - 43. Transmission housing cover - 44. Spring.

**Note** - Upon reassembly, apply jointing compound to mating surfaces **X** as instructed on page 6, Sect. A, for Mods. 466/566/666/766.

**REMOVAL - INSTALLATION**



Lift and handle all heavy parts using a suitable hoist. Ensure that units or parts are supported by suitable slings or hooks. Ensure that no one is in the vicinity of load to be lifted.

Drain transmission-rear drive housing oil and proceed as follows:

- Disconnect battery negative lead and electrical leads of power point and fender-mounted signal lights from their connections.
- Disconnect lift lines, transmission clutch control link from outer control lever and accelerator control link from pedal.
- For DT models, remove front axle drive shaft and associated guard.
- Remove fenders (complete with fuel tank, Mods. 60-66F/70-66F/80-66F) footboards and lift.
- Install a mechanical stand under rear of drive housing and remove wheels, final drives, brake units and

transmission/splitter control lever plastic board.

- Connect transmission housing to hoist through lift hook **291517**.
- Install mechanical stand under clutch housing, remove screws securing transmission-rear drive housing to clutch housing and remove transmission-rear drive assy.

Before installing transmission housing on clutch housing after overhaul, thoroughly clean and degrease mating surfaces and apply 2 mm (0.08 in), bead jointing compounds as indicated in figure on page 1, Sect. 202, for Mod. 45-66.

Jointing compound types to be used are indicated on page 6, section A for Mods. 466/566/666/766.

**TRANSMISSION REMOVAL - INSTALLATION:  
MODS. 45-66V/55-66V/55-66F**

Refer to the descriptions and illustrations shown on pages 1 thru 6, Sect. 202 for Mod. 45-66.

The figures published on this page replace their counterparts given on page 4, Sect. 202 for Mod. 45-66.

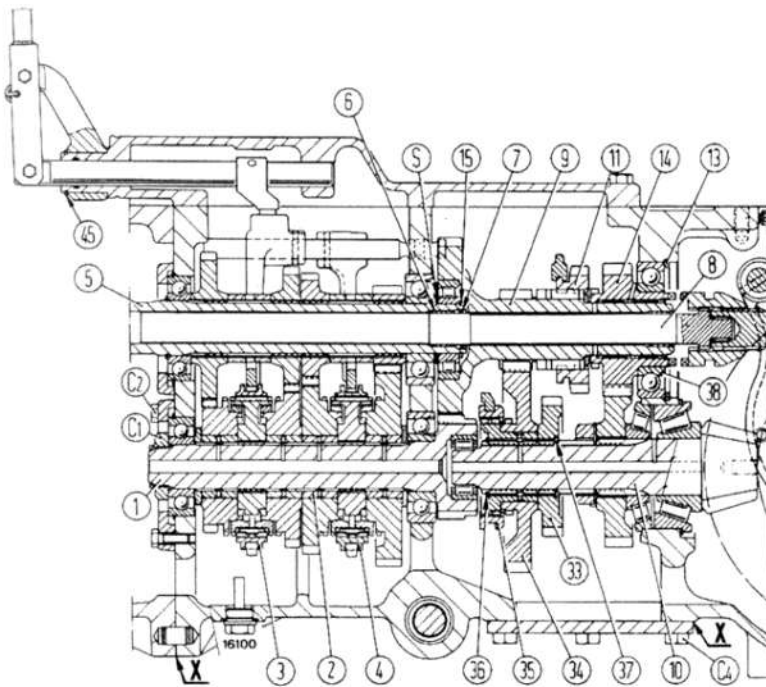

**Longitudinal and cross sections through transmission and splitter  
- Mods. 60-66F/70-66F/80-66F.**

C<sub>1</sub>. Driven gear drive shaft lock nut - C<sub>2</sub>. Bearing cover retaining screws - C<sub>3</sub>. Top cover retaining screws - C<sub>4</sub>. Bottom cover retaining screws - S. Drive shaft bearing shim - 1. Transmission driven shaft - 2. Transmission driven gear support bushings - 3. 3rd/4th sliding sleeve - 4. 1st/2nd sliding sleeve - 5. Transmission drive shaft - 6. PTO shaft bush - 7. Seal - 8. PTO shaft - 9. Direct drive and low range drive shaft - 10. Bevel drive pinion shaft - 11. Reverse/Normal range sliding gear - 13.-15.-36.-45. Retaining rings - 14. Normal range drive gear - 16. Transmission shift lever - 17. Splitter shift lever - 18. 1st/2nd speed striker rod - 19. 3rd/4th striker rod - 20. Low/High range striker rod - 21. Normal/Reverse range striker rod - 22. Transmission shift control horizontal relay bar - 23. Splitter shift control horizontal relay bar - 33. Reverse gear - 34. Low range driven gear - 35. Low range/Direct drive sliding sleeve - 37. Rings - 38. Bearings - 39. Transmission shift plunger - 40. Splitter shift plunger - 41. Transmission shift lever fulcrum support - 42. Splitter shift lever fulcrum support - 43. Transmission housing cover - 44. Spring.

**Note** - Upon reassembly, apply jointing compound to mating surfaces **X** as instructed on page 6, Sect. A, for Mods. 466/566/666/766.

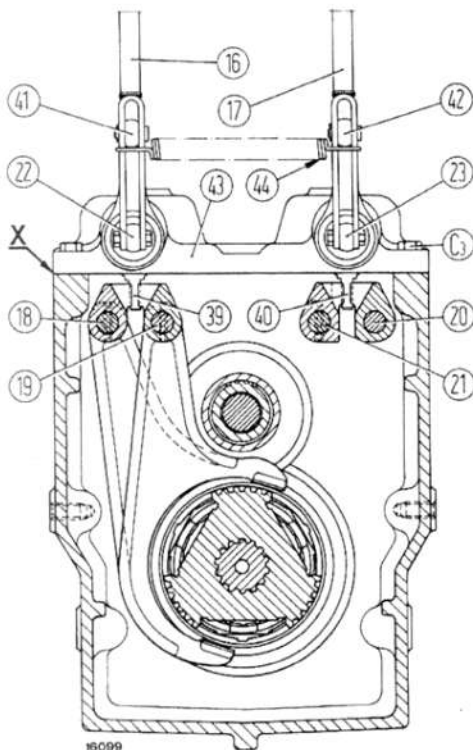

**TRANSMISSION REMOVAL-INSTALLATION: MODS.  
60-66F/70-66F/80-66F**

Refer to the descriptions and illustrations shown on pages 1 thru 4, Sect. 202 for Mods. 55-66/60-66/70-66/80-66. The Figures published on this page replace their counterparts given on page 1, Sect. 202, for Mods. 55-66/60-66/70-66/80-66.

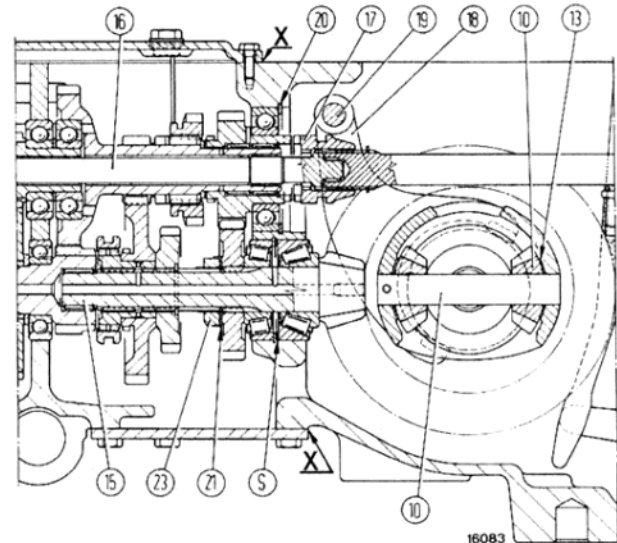
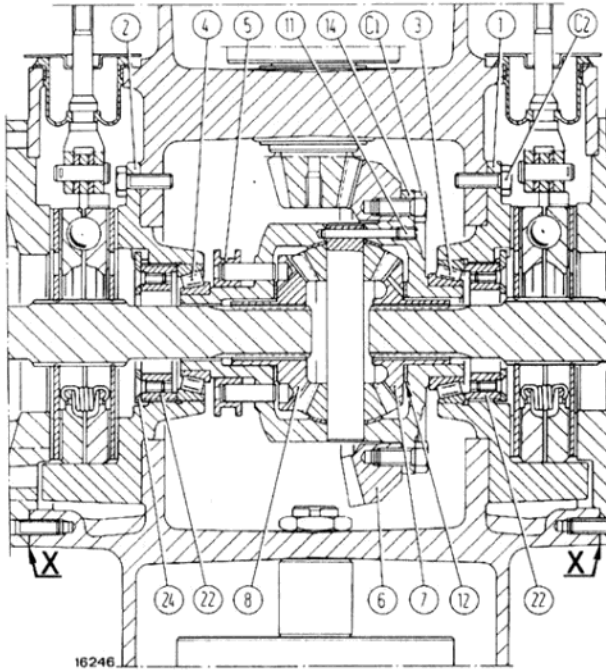

**Longitudinal and cross sections through bevel drive and differential Mods. 45-66V/55-66V/55-66F.**

C1. Bevel ring gear retaining screws - C2. Differential support retaining screws - S. Bevel pinion positioning shims - 1 and 2. Differential supports - 3 and 4. Taper roller bearings - 5. Differential lock sleeve - 6. Bevel ring gear - 7. and 8. Side gears - 9. Differential pinion - 10. Journal - 11. Differential pinion journal retaining screw - 12 and 13. Shims - 14. Differential carrier - 15. Bevel pinion shaft - 16. P.T.O. shaft - 17. P.T.O. control sleeve - 18. Fork - 19. Differential lock shaft - 20. Retaining ring - 21. Lockwasher - 22. Differential bearing adjuster ring - 23. Bevel pinion shaft bearing adjuster nut - 24. Lock washers.

**Note** - On assembly, thoroughly clean and degrease mating surfaces **X** and apply one of the jointing compounds indicated on page 6, Sect. A, for Mods. 466/566/666/766.

### BEVEL DRIVE - DIFFERENTIAL REMOVAL

Proceed as follows:

- Drain drive housing oil.
- Disconnect battery negative lead, power point wiring and lift lines.
- Remove ROPS frame, fenders (complete with fuel tank on Mods. 60-66F/70-66F/80-66F) and remote control valves, when fitted.
- Remove Operator's seat, lift with control levers and transmission housing top cover with levers.
- Position a support stand under rear drive housing, then remove wheels, side final drives, brake units, sensing bar support and PTO (Mods. 45-66V/55-66V/55-66F) or PTO housing (Mods. 60-66F/70-66F/80-66F)
- Take off bearing supports and remove bevel drive/differential unit from top of rear drive housing (Mods. 45-66V/55-66V/55-66F) or from rear end of same (Mods. 60-66F/70-66F/80-66F).

### BEVEL PINION SHAFT REMOVAL

Proceed as follows:

- For Mods. 45-66V/55-66V/55-66F - as instructed on page 1, Sect. 204, for Mod. 45-66.

- For Mods. 60-66F/70-66F/80-66F - as instructed on pages 1 and 2, Sect. 204, for Mods. 55-66/66-66/70-66/80-66.

### BEVEL DRIVE ADJUSTMENT

**Bevel pinion position adjustment and shim thickness determination. Pinion shaft bearing adjustment.**

- Mods. 45-66V/55-66V/55-66F - Proceed as instructed on pages 1, 2 and 3, Sect. 204, for Mod. 45-66.
- Mods. 60-66F/70-66F/80-66F - Proceed as instructed on pages 2, 3 and 4, Sect. 204, for Mods. 55-66/60-66/70-66/80-66.

**Differential bearing adjustment and bevel drive backlash check**

- Mod. 45-66V/55-66V/55-66F - Proceed as instructed on pages 3, 4 and 5, Sect. 204, for Mod. 45-66.
- Mods. 60-66F/70-66F/80-66F - Proceed as instructed on pages 7 and 8, Sect. 204, for late Mods. 466/566/666/766.

### DIFFERENTIAL PINION AND SIDE GEAR BACKLASH ADJUSTMENT

Refer to text and illustrations on pages 8 and 9, Sect. 204, Mods. 466/566/666/766.

### DIFFERENTIAL LOCK INSTALLATION AND ADJUSTMENT

Assemble differential lock components using tool **293452**

# POWER TRAIN: Bevel Drive and Differential

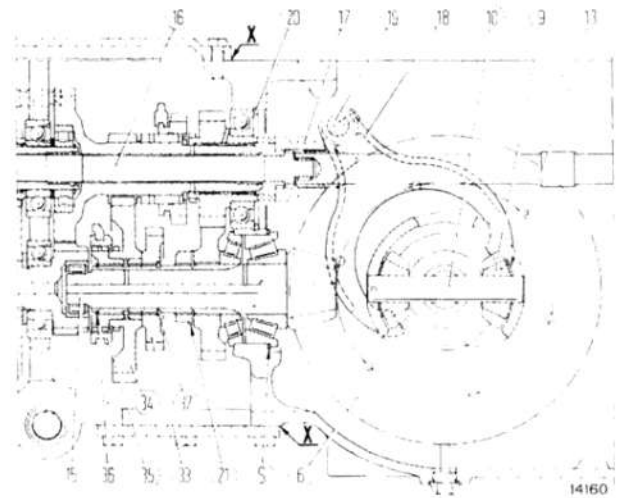
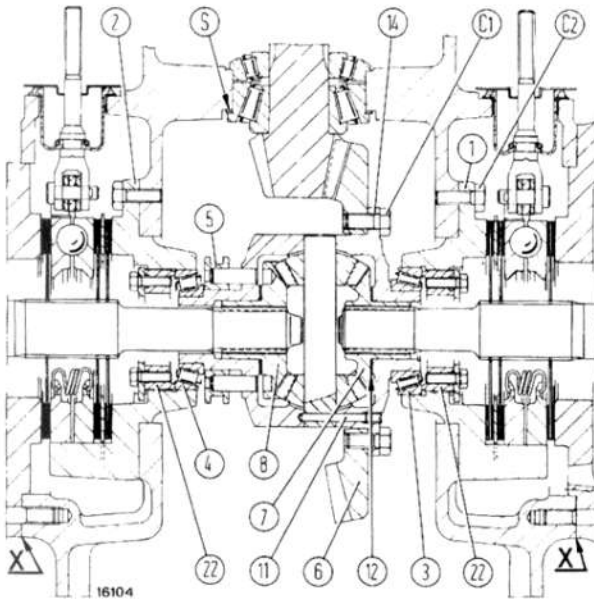

**Longitudinal and cross sections through bevel drive and differential Mods. 40-66F/70-66F/80-66F.**

C<sub>1</sub>. Bevel ring retaining screws - C<sub>2</sub>. Differential support retaining screws - S. Bevel pinion positioning shims - 1 and 2. Differential supports - 3 and 4. Taper roller bearings - 5. Differential lock sleeve - 6. Bevel ring gear - 7 and 8. Side gears - 9. Differential pinion - 10. Journal - 11. Differential pinion journal retaining screw - 12 and 13. Shims - 14. Differential carrier - 15. Bevel pinion shaft - 16. P.T.O. shaft - 17. P.T.O. control sleeve - 18. Fork - 19. Differential lock shaft - 20. Retaining ring - 21. Lockwasher - 22. Differential bearing adjuster ring nut - 33. Reverse gear - 34. Creeper driven gear - 35. Creeper and DD engagement sleeve - 36. Retaining ring - 37. Shims.

**Note** - On assembly, thoroughly clean and degrease mating surface X and apply one of the jointing compounds indicated on page 6, section A, for Mods. 466/566/666/766.

to compress return spring (5) and to introduce the fork (4) to-shaft roll pin (6).

Using a feeler gauge, check that clearance (G) between sleeve (7) and R.H. differential bearing is 2 mm (0.08 in).

Install bevel ring gear-differential unit on supports.

Adjust clearance by changing shims (S) between support (2) and drive housing.

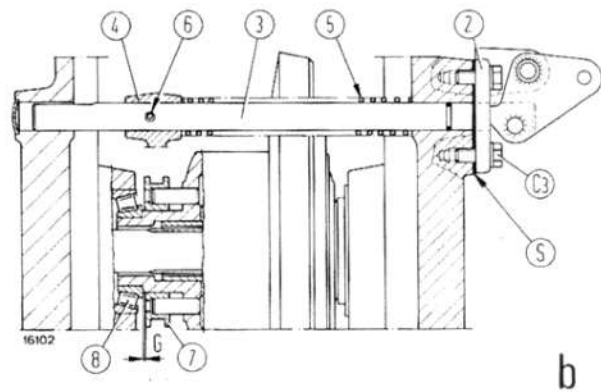
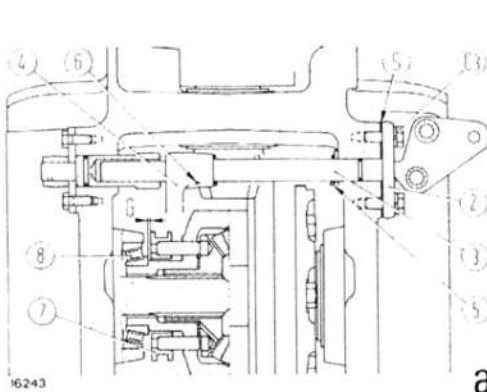

**Installing and adjusting differential locks.**

a. Mods. 45-66V/55-66V/55-66F - b. Mods. 60-66F/70-66F/80-66F - C<sub>3</sub>. Screws - G = 2 mm (0.08 in). Clearance between sleeve (7) and bearing (8) - S. Sleeve positioning shims - 2. Lever support - 3. Fork shaft - 4. Fork - 5. Spring - 6. Roll pin - 7. Differential lock sleeve - 8. Differential bearing.

**Sections through brake unit.**

- a. Models 45-66V/55-66V/55-66F -  
b. Models 60-66F/70-66F/80-66F -  
C<sub>2</sub>. Differential support screws - 1.  
Brake link - 2. Pin - 3. Ball - 4. Brake  
actuator - 5. Brake discs - 6. Back-  
up disc - 7. Actuator pull-off spring  
- 8. Differential support - 9. Axle  
shaft - 10. Boot cover plate - 11.  
Boot.

**Note** - On assembly, apply jointing  
compound to surfaces **X** as  
directed in notes and in diagram on  
page 2, Sect. 205, Mods. 55-66LP/  
60-66LP/70-66LP.

**Important** - New brake discs **must**  
**be** soaked for at least **2 hours**, and  
preferably for 5 to 6 hours, in  
TUTELA MULTI F oil before in-  
stallation.

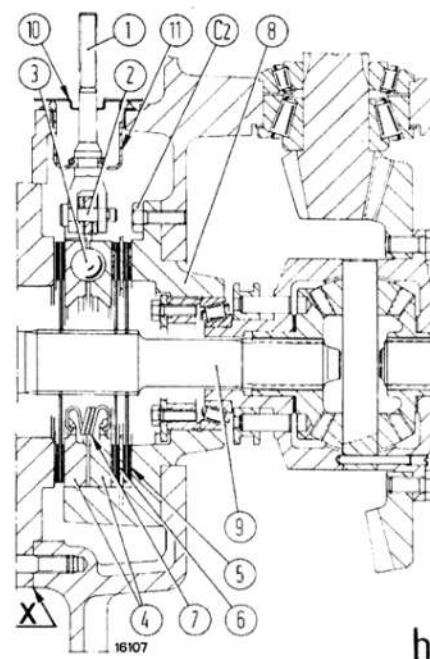
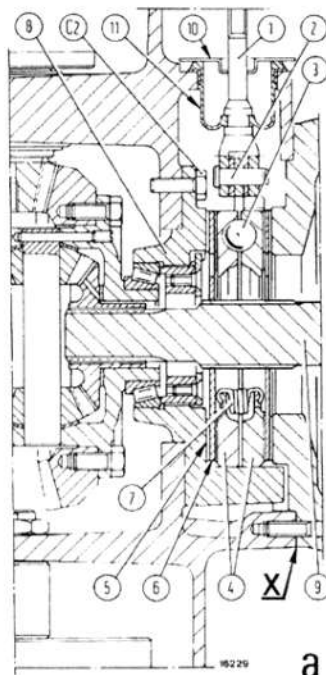

**BRAKE UNIT REMOVAL AND  
INSTALLATION**



**CAUTION**

Lift and handle all heavy components using a suitable hoist. Ensure that units or parts are supported by suitable slings or hooks. Ensure that no one is in the vicinity of the load to be lifted.

Disassemble brake unit as follows:

- Drain rear drive housing oil.
- Position a support stand under drive housing, unscrew retaining stud nuts (C<sub>1</sub>, page 1, Sect. 206) and remove splitter housing.
- Remove cotter pin and pin (2) securing brake pedal to link (1).
- Back off link (1) from spring side and remove complete brake unit.
- Check actuator (4) and brake discs (5) for wear. Replace discs when sintered material is almost worn out.

On brake unit installation, use driver **293847** as shown to position boot (11) correctly on brake link (1).

Before installing side final housing on drive housing, thoroughly clean and degrease mating surfaces and apply a 2 mm (0.08 in) bead of jointing compound as shown

in Figure on page 2, Sect. 205, for Mods. 55-66LP/  
60-66LP/70-66LP.  
Jointing compound types are indicated on page 6, Sect.  
A for Mods. 466/566/666/766.

**BRAKE PEDAL ADJUSTMENT (Mods. 45-66V/55-  
66V/55-66F)**

Check that free travel is the same for both pedals and does not exceed 70 mm (2.75 in).

To adjust, proceed as follows:

- Move brake lock lever downwards.
- Back off jam nuts (A, page 2) (one on either side) and turn sleeves (B) (one on either side) until free travel is 40 mm (1.57 in).
- Lock jam nuts (A).

**PARKING BRAKE HAND LEVER ADJUSTMENT  
(Mods. 45-66V/55-66V/55-66F)**

From its position of rest, the drive train hand brake lever shall move by four clicks to fully restrain the tractor. For re-adjustments, unscrew jam nut (A, page 2) which is LH threaded, and turn nut (B) until the hand lever free travel is again set to 4 clicks on ratchet, then lock by jam nut (A).

## POWER TRAIN: Brakes

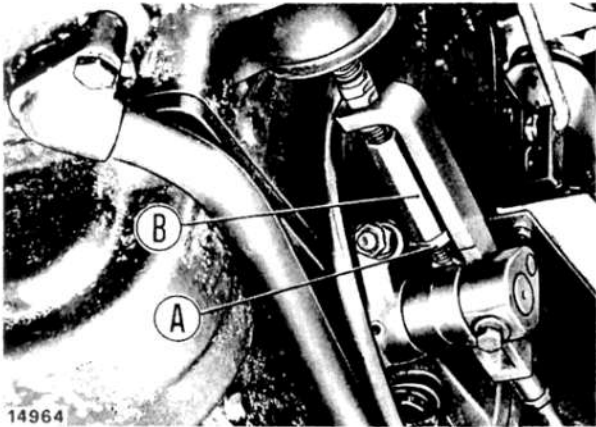

**Brake pedal adjustment (Mods. 45-66V/55-66V and 55-66F).**

A. Jam nuts - B. Adjuster sleeves.

### BRAKE PEDAL ADJUSTMENT (Mods. 60-66F/70-66F/80-66F).

Check that pedal free travel is the same for both pedals and does not exceed 80 mm (3.15 in).

To adjust, proceed as follows:

- Move brake lock lever downwards.
- Back off jam nuts (A) and turn sleeves (B) until free travel is 45 mm (1.77 in).
- Lock jam nuts (A).

### PARKING BRAKE HAND LEVER ADJUSTMENT (Mods. 60-66F/70-66F/80-66F)

After re-setting brake pedal free travel, check hand brake control on either side for correct adjustment, proceeding as follows:

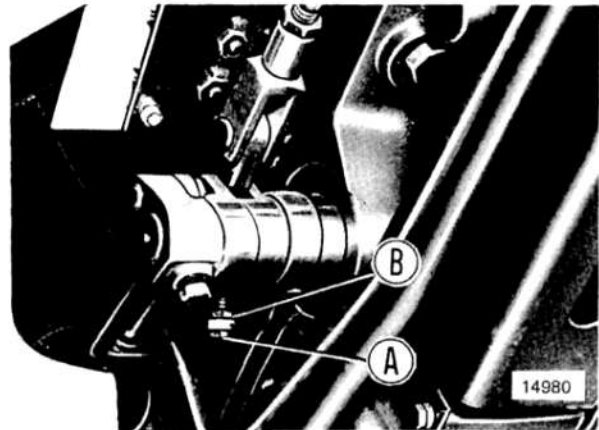

**Parking brake hand lever adjustment (Mods. 45-66V/55-66V/55-66F).**

A. Jam nut - B. Nut.

- Back off jam nut (C).
- Turn adjuster sleeve (D) into contact with bracket (E).
- Lock jam nut (C).

Next, re-set brake hand lever travel by operating on RH rod, as follows:

- Back off jam nut (F) which is LH threaded.
- Turn in or out nut (G) as required checking at the same time that lever «locks» at the 4th click on ratchet.
- Lock jam nut (F).

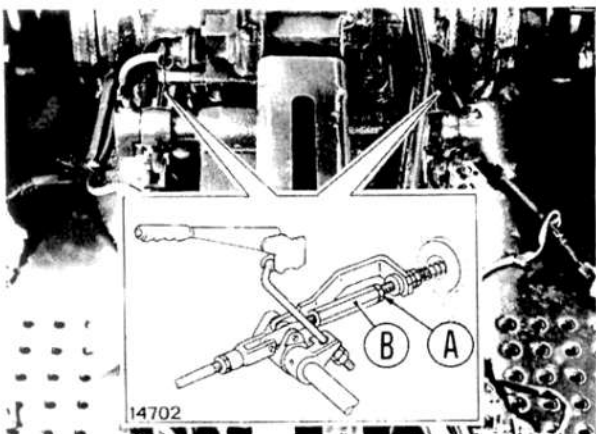

**Brake pedal adjustment (Mods. 60-66F/70-66F/80-66F).**

A. Jam nuts - B. Adjuster sleeves.

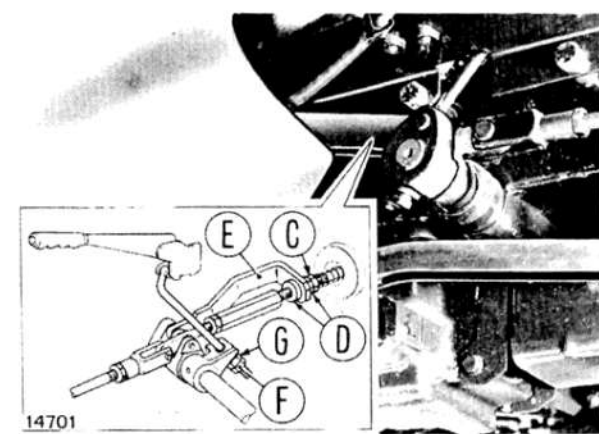

**Parking brake hand lever adjustment (Mods. 60-66F/70-66F/80-66F).**

C. Jam nut - D. Adjuster sleeve - E. Bracket - F. Jam nut - G. Nut.

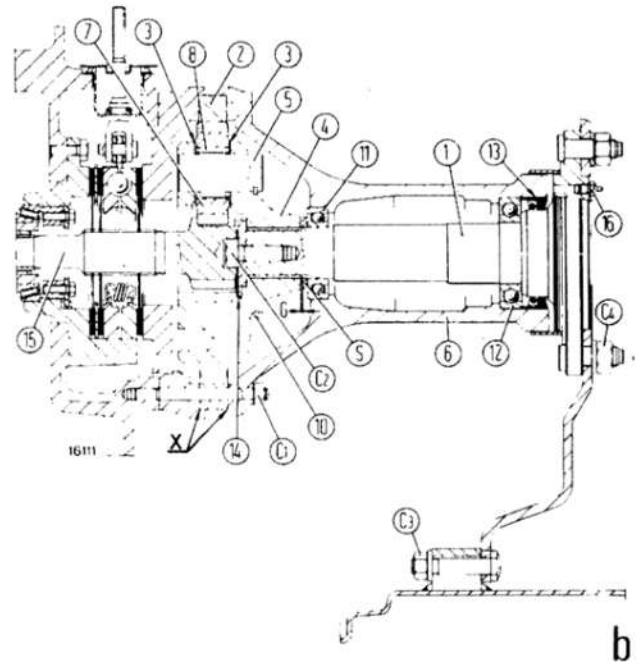
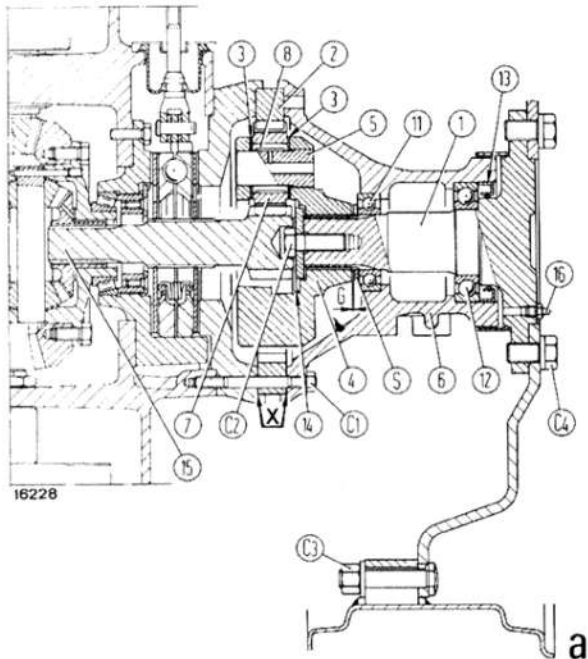

**RH Final Drive longitudinal section.**

a. Mods. 45-66V/55-66V/55-66F - b. Mods. 60-66F/70-66F/80-66F - C<sub>1</sub>. Nuts, final drive housing studs - C<sub>2</sub>. Lock screw, wheel drive shaft - C<sub>3</sub>. Nut, sheet metal disc-to-driving wheel rim screw - C<sub>4</sub>. Screw, sheet metal disc to driving wheel hub - G. = 0.2 to 0.4 mm (0.0078 to 0.0157 in) Planet gear carrier end play - S. Shims, end play (G) adjustment - 1. Wheel drive shaft - 2. Ring gear - 3. Thrust washers - 4. Planet gear carrier, epicyclic final drives - 5. Planet gear journal - 6. Final drive housing - 7. Planet gear - 8. Needle roller bearing - 10. Retaining ring, planet gear journals - 11 and 12. Ball bearings - 13. Seal - 14. Lock washer, screw (C<sub>2</sub>) - 15. RH sun gear shaft - 16. Grease fitting.

**Note** - On assembly, apply jointing compound to surfaces **X** as instructed on page 6, Sect. A, for Mods. 466/566/666/766.

**REMOVAL**



Raise and handle all heavy components using a suitable hoist. Ensure that units or parts are supported by suitable slings or hooks. Ensure that no one is in the vicinity of the load to be lifted.

Remove final drives as follows:

- Drain oil from rear drive housing.
- Position a support stand under drive housing, take out nuts (C<sub>1</sub>) and remove final drive housing assy.

**DISASSEMBLY - ASSEMBLY**



Handle all parts with extreme care. Do not put hands and fingers between parts. Wear safety items such as goggles, gloves and shoes.

Disassemble and reassemble final drives according to the instructions and illustrations provided on pages 1 and 2, Sect. 206, for Mods. 55-66LP/60-66LP/70-66LP.

**206**

*page 2*

***POWER TRAIN:***

**DEAD FRONT AXLE**

	45-66V	655-66V	55-66F	60-66F	70-66F	80-66F
Type .....	inverted U beam, telescoping, center pivoting					
Track settings .....mm ..... in	965-1050 <sup>(1)</sup> (38-41)		985-1085 <sup>(2)</sup> (38.8-42.7)		1185-1285-1385-1485 (46.6-50.6-54.5-58.5)	
<b>Axle articulation</b>						
Pivot pin diameter ..... mm ..... in	29.967 to 30.000 (1.1798 to 1.1811)			37.961 to 38.000 (1.4945 to 1.4960)		
Press-fitted bushing bore ..... mm ..... in	30.100 to 30.150 (1.1850 to 1.1870)			38.050 to 38.140 (1.4980 to 1.5015)		
Kingpin-to-bushing clearance ..... mm ..... in	0.100 to 0.183 (0.0039 to 0.0072)			0.050 to 0.179 (0.0589 to 0.0070)		

**HYDROSTATIC POWER STEERING**

	45-66V	55-66V	55-66F	60-66F	70-66F	80-66F
Type .....	Hydrostatically controlled					
Make .....	DANFOSS					
Hydraulic system .....	independent oil supply from hydraulic pump					
Oil tank .....	transparent plastic located on engine RH side					
Oil filter .....	metal cartridge, incorporated in oil tank					
<b>Hydraulic pump</b>						
Type .....	gear					
Model .....	C 25 <sup>(3)</sup> or A18 <sup>(4)</sup>					
Make .....	FIAT					
Drive .....	from engine valve gear <sup>(3)</sup> or from engine crankshaft <sup>(4)</sup>					
Rotation (viewed from drive end) .....	clockwise <sup>(3)</sup> or anti-clockwise <sup>(4)</sup>					
Engine/Pump drive ratio .....	0.931 to 1 <sup>(3)</sup> or 1 to 1 <sup>(4)</sup>					
Rated speed (at engine governed speed) ..	26.4 l/min (46 pints/min) <sup>(3)</sup> or 20.5 l/min (36 pints/min) <sup>(4)</sup>					
On-bench output at 1450 rpm and 68.5 bar (70 kg/cm <sup>2</sup> , 993 psi):						
— New or reconditioned pump .....	15.3 l/min (27 pints/min) <sup>(3)</sup> or 11 l/min (19 pints/min) <sup>(4)</sup>					
— Used pump .....	10.7 l/min (19 pints/min) <sup>(3)</sup> or 7.7 l/min (13 pints/min) <sup>(4)</sup>					

<sup>(1)</sup> 865-965 mm (34-38 in) w/size 4.00-15 tyres

<sup>(2)</sup> 1040-1140 mm (41-45 in) w/size 6.00-16 tyres

<sup>(3)</sup> 45-66V, 45-66DTV, 55-66V, 55-66DTV, 55-66F, 55-66DTF, 60-66F, 70-66F and 80-66F tractors.

<sup>(4)</sup> 60-66DTF, 70-66DTF and 80-66DTF tractors.

## FRONT AXLE-STEERING: Specifications and Data

### HYDROSTATIC POWER STEERING

	45-66V	655-66V	55-66F	60-66F	70-66F	80-66F
Pump C25 mechanical data . . . . .	Data on pages 1 and 2, Sect. 30, for Mods. 55-66/60-66/70-66/80-66					
Pump A18 mechanical data . . . . .	Data on pages 3 and 4, Sect. 30, for Mods. 466/566/666/766 (C 18X)					
<b>Rotary contro valve</b>	DANFOSS  Steering post-controlled rotary valve: steering is possible also in case of pump failure  OSPC 100					
Make . . . . .						
Design . . . . .						
Identification Code . . . . .						
Pressure relief valve setting . . . . .	100 bar (102 kg/cm <sup>2</sup> or 1450 psi)					
Power cylinder overload valve setting . . . . .	200 bar (204 kg/cm <sup>2</sup> or 2845 psi)					

### TORQUE DATA: MODS 45-66V/55-66V/55-66F

ITEM	THREAD SIZE	TORQUE		
		Nm	kgm	ft lb
<b>Front Axle - Sect. 301</b>				
Nut, axle support to engine . . . . .	M16x1.5	220	22.6	162.7
Screw, axle articulation pivot pin . . . . .	M10x1.5	59	6	43.4
Nut, axle end screw . . . . .	M16x1.5	211	21.5	153
Screw, wheel to hub (Cs, page 1) . . . . .	M20x1.5	216	22	159
Nut, drag link/track rod articulation end fittings . . . . .	M14x1.5	134	14	101.3
Nut, RH/LH steering knuckle arms . . . . .	M10x1.25	49	5	36

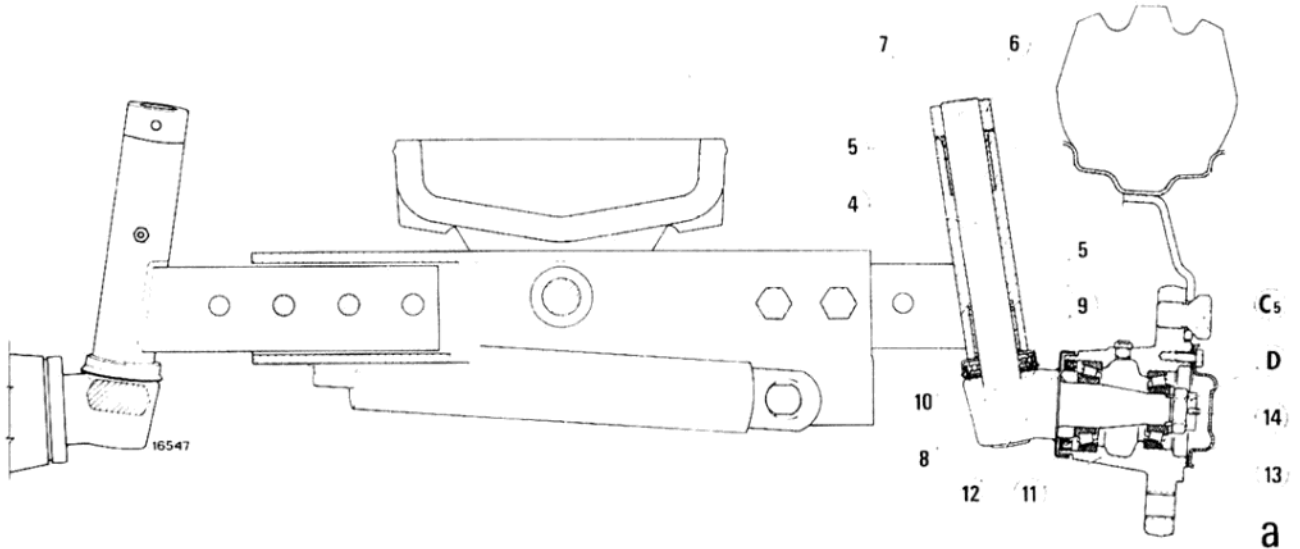

**Front axle section - Mods. 45-66V/55-66V-55-66F.**

Cs. Screw, steering wheel rim to hub - D. Nut, wheel bearing adjustments - 4. Steering knuckle kingpin - 5. Bushings - 6. Ring, steering knuckle - 7. Seal - 8. Ball bearing - 9. Bearing cup - 10. O-ring - 11. Wheel hub - 12. Seal - 13. Hub cover - 14. Split pin.

**FRONT WHEEL GEOMETRY CHECKS  
Mods. 45-66V/55-66V/55-66F**

Proceed as follows:

— In straightahead drive position front wheel camber shall be  $3^\circ$ , equivalent to a difference of approximately 20 mm (7.87 in) between rim top and bottom edge centers - see detail (a) in illustration.

A slight front end toe-in is allowed up to 0.5 mm (0.1968 in) max - see detail (b) in illustration.

— If toe-in adjustments are needed, turn in or out as required the adjustable ends of track rods.

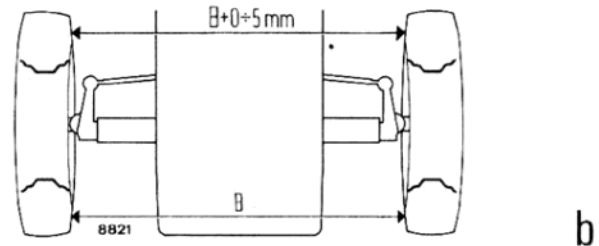
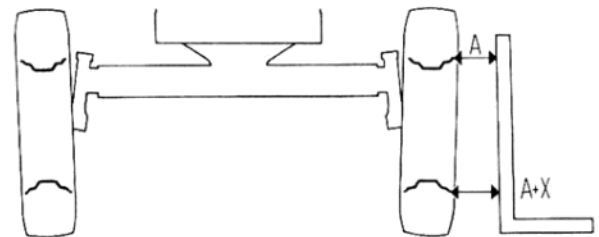

**FRONT WHEEL HUB TAPER ROLLER BEARING ADJUSTMENTS  
Mods. 45-66V/55-66V/55-66F**

After assembly, tighten nut (D) gradually until a revolving torque of 0.2-0.3 Nm (0.02 to 0.03 kgm or 0.145 to 0.217 ft lb) is obtained.

This torque is equivalent to a spring balance (dynamometer) force of 6 to 8 N (0.6 to 0.85 kg or 1.3 to 1.9 lb) as determined with a string wound around hub as shown in detail (C).

After adjustments, secure nut (D) by split pin (14).

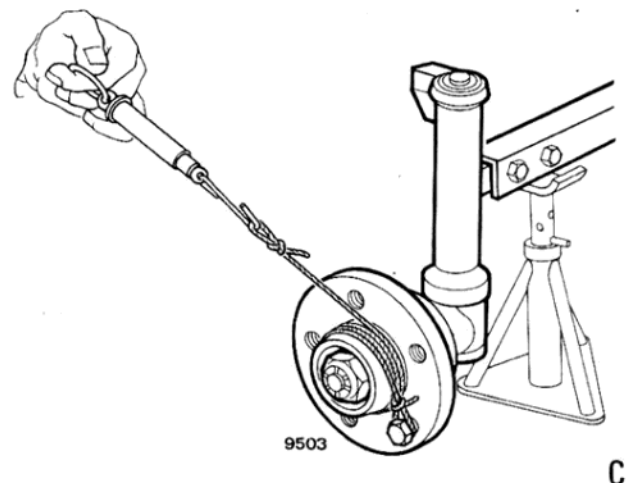

---

**301**

*page 2*

**FRONT AXLE-STEERING:**

---

**LIVE FRONT AXLE**

	45-66DTV, 55-66DTV	55-66DTF	60-66DTF, 70-66DTF, 80-66DTF
Design . . . . .	Steering, full-floating, center pivoting		
Axle input drive ratio . . . . .	15 to 29 = 1 to 1.933	—	—
<b>Bevel Drive and Differential</b>			
Bevel drive ratio . . . . .	8 to 35 = 1:4.375	13 to 37 = 1:2.846	10 to 36 = 1:3.6
Bevel drive backlash . . . . .	0.15 to 0.20 mm (0.006 to 0.008 in)		
Bevel pinion bearing shim thickness (S <sub>1</sub> , pages 3 and 5, Sect. 402) . . . . .	—	2.50-2.55-2.60-2.65-2.70-2.75-2.80-2.85-2.90 2.95-3.00-3.05-3.10-3.15-3.20-3.25-3.30-3.35 3.40-3.45-3.50-3.55-3.60-3.65-3.70 (0.098-0.100-0.102-0.104-0.106-0.108-0.110 0.112-0.114-0.116-0.118-0.120-0.122-0.124 0.126-0.128-0.130-0.132-0.134-0.136-0.138 0.140-0.142-0.144-0.146 in)	
Bevel pinion spacer thickness (S <sub>1</sub> , page 6, Sect. 402)	39.50-39.60-39.70- 39.80-39.90-40-40.10- 40.20-40.30-40.40 mm (1.555-1.559-1.563- 1.567-1.571-1.575- 1.579-1.583-1.587- 1.591 in)	—	
Bevel pinion shim thickness (S <sub>2</sub> ) . . . . .	0.20-0.25-0.30 mm (0.0078-0.0098- (0.0118 in)	2.5-2.6-2.7-2.8-2.9-3-3.1-3.2-3.3-3.4-3.5- 3.6-3.7 mm (0.098-0.102-0.106-0.110-0.114-0.118-0.122- 0.126-0.130-0.134-0.138-0.142-0.146 in)	
Differential pinion and side gear backlash . . . . .	0.18 mm	0.15 mm (0.006 in)	
Side gear thrust washer thickness (7, page 3, 5 and 6, Sect. 402) . . . . .	2 mm (0.08 in)	1.470 to 1.530 mm (0.0579 to 0.0602 in)	
Differential side gear thrust washer thickness . . . . .	2 mm (0.08 in)	1.50-1.60 mm-(0.0590-0.0630 in)	
Differential pinion journal dia . . . . .	17.982 to 18.000 mm (0.7079 to 0.7086 in)	21.939 to 21.960 mm (0.864 to 0.865 in)	
Differential pinion journal bore dia . . . . .	18.050 to 18.071 mm (0.7106 to 0.7114 in)	22.040 to 22.061 mm (0.868 to 0.869 in)	
Differential pinion journal clearance in pinion bore . . . . .	0.050 to 0.089 mm (0.00197 to 0.00350 in)	0.080 to 0.122 mm (0.003 to 0.006 in)	
<b>Axle Shafts and Joints</b>			
Axle shaft journal diameter (5, page 3, 5, 6, Sect. 402)	37.975 to 38.000 mm (1.4950 to 1.4960 in)	29.914 to 29.935 mm (1.178 to 1.179 in)	
Axle bushing fitted I.D. (14) . . . . .	38.050 to 38.089 mm (1.4980 to 1.4995 in)	30.050 to 30.105 mm (1.183 to 1.185 in)	
Axle shaft running clearance in bushing . . . . .	0.050 to 0.114 mm (0.00197 to 0.00449 in)	0.115 to 0.191 mm (0.004 to 0.007 in)	
Bushing interference fit in housing . . . . .	0.009 to 0.059 mm (0.00035 to 0.00232 in)	0.064 to 0.129 mm (0.003 to 0.005 in)	
King pin bearing shim thickness (S <sub>3</sub> , page 3, 5, 6 Sect. 402) . . . . .	0.20-0.25-0.50 mm (0.008-0.010-0.020 in)	0.10-0.15-0.20-0.25-0.30 mm (0.004-0.006-0.008-0.010-0.012 in)	
<b>Planetary Final Drives</b>			
Reduction ratio . . . . .	—	15 to (15 + 54) = 1 to 4.6	
Driven gear thrust washer thickness (18, page 3, 5, 6, Sect. 402) . . . . .	—	0.77 to 0.83 mm (0.030 to 0.033 in)	

## FRONT WHEEL DRIVE: Specifications and Data

### LIVE FRONT AXLE

	45-66DT, 55-66DTV	55-66DTF	60-66DTF, 70-66DTF, 80-66DTF
<b>Center Pivot</b>			
Center pivot O.D. . . . . .	29.967 to 30.000 mm (1.1798 to 1.1811 in)	—	—
Center pivot bushing fitted I.D. . . . . .	30.010 to 30.015 mm (1.1815 to 1.1817 in)	—	—
Pivot working clearance in bushing . . . . .	0.010 to 0.048 mm (0.0004 to 0.0019 in)	—	—
Centre pivot diameter . . . . .	—	52.652 to 52.671 mm (2.0729 to 2.0737 in)	—
Centre pivot front bushing fitted I.D. . . . . .	—	52.720 to 52.790 <sup>(1)</sup> mm (2.0756 to 2.0783 in)	—
Centre pivot working clearance in bushing . . . . .	—	0.049 to 0.138 mm (0.0019 to 0.0054 in)	—
Rear bevel pinion carrier spigot O.D. . . . . .	—	99.040 to 99.072 mm (3.8992 to 3.9005 in)	—
Rear bushing fitted I.D. . . . . .	—	99.146 to 99.221 <sup>(1)</sup> mm (3.9033 to 3.9063 in)	—
Spigot fitted clearance in bushing . . . . .	—	0.074 to 0.181 mm (0.0029 to 0.0071 in)	—
Axle thrust washer thickness . . . . .	3.925 to 4.000 mm (0.1545 to 0.1575 in)	4.95 to 5.00 mm (0.1949 to 0.1968 in)	—

<sup>(1)</sup> Not reamed

### AXLE DRIVE

	45-66DT, 55-66DTV	55-66DTF	60-66DTF, 70-66DTF, 80-66DTF
Reduction ratio . . . . .	34/24x18/40 = 1 to 1.57	34/25x25/38 = 1 to 1.12	34/24x24/34 = 1 to 1
Relay lever pad width . . . . .	7.978 to 8.000 mm	7.978 to 8.000 mm	(0.3141 to 0.3149 in)
Pad seat width in driven gear . . . . .	8.280 to 8.370 mm	8.280 to 8.370 mm	(0.3260 to 0.3295 in)
Pad clearance in seat . . . . .	0.280 to 0.392 mm	0.280 to 0.392 mm	(0.0110 to 0.054 in)
Relay lever pivot diameter . . . . .	15.973 to 16.000 mm	15.973 to 16.000 mm	(0.6288 to 0.6299 in)
Pivot housing bore in casing . . . . .	16.016 to 16.059 mm	16.016 to 16.059 mm	(0.6305 to 0.6322 in)
Pivot clearance in housing . . . . .	0.016 to 0.086 mm	0.016 to 0.086 mm	(0.0006 to 0.0034 in)
Relay lever detent spring length			
— Free . . . . .		24.5 mm	(0.9646 in)
— Under 178.2 to 197.8 N (18.17 to 20.17 kg or 40 to 44 lb) . . . . .		19.3 mm	(0.7598 in)

### DRIVE SHAFT

	45-66DT, 55-66DTV	55-66DTF	60-66DTF, 70-66DTF, 80-66DTF
Front drive sleeve adjustment . . . . .	—	See page 1, Sect. 402, Mods. 466-566/666/766	—
Front drive sleeve shim thickness (S <sub>s</sub> , page 5-6, Sect. 402) . . . . .	—	2.2-2.5-2.8-3-3.3-3.7-4-4.3 mm (0.087-0.098-0.101-0.118-0.130-0.146- 0.158-0.170 in)	—

## REMOVAL



Lift and handle all heavy parts using a suitable hoist. Ensure that units or parts are supported by suitable slings or hooks. Ensure that no one is in the vicinity of the lifted load.

Mods. 55-66DTF/60-66DTF/70-66DTF/80-66DTF - proceed as instructed on page 1, Sect. 401 for Mods. 466DT/566DT/666DT/766DT.

Mods. 45-66DTF and 55-66DTF - Proceed as follows:

- Remove the two drive shaft guards.
- Backoff the two bolts securing U-jointed drive shaft to bevel pinion and to splined input shaft; next, turn in U-jointed drive shaft until it uncouples from axle bevel pinion.
- Remove power steering cylinder and articulation pins; place a hydraulic jack centrally under housing and remove wheels.
- Place a stand under engine sump at front, remove front and rear axle pivots and, lowering jack, separate assy from tractor.
- Secure axle assy to universal stand, disconnect track rod then remove and drain oil from axle housing.

## DISASSEMBLY



Handle all parts carefully. Do not put hands and fingers between parts. Wear safety goggles, shoes and gloves.

### **Servicing - Epicyclic final drives, wheel hubs and steering knuckles - Mods. 55-66DTF/60-66DTF/70-66DTF/80-66DTF.**

Proceed as instructed in text and illustrations on pages 1 and 2, Sect. 401 for Mods. 466DT and 566DT.

### **Servicing-wheel, hub and steering knuckle Mods. 45-66DTV and 55-66DTV.**

Overhaul may also be carried out with axle installed on tractor.

In this case, lock parking brake and place a stand at the center of axle housing.

Disassemble parts in the following order:

- Remove wheel hub side cover.
- Straighten lockwasher tab and backout hub bearing ring nut.
- Remove wheel hub.
- Remove steering knuckle bearings and knuckle carrier.

Replace worn bearings using suitable punches and universal pullers. Check seal efficiency.

Assemble axle parts referring to Figures on page 4, Sect. 402 for correct positioning and note the following:



Use suitable tools to align holes. **DO NOT USE FINGERS OR HANDS.**

- Before installing knuckle carrier, introduce the articulated wheel drive shaft in axle housing sleeve and lubricate bore of bushing (14, page 6) with **FIAT TUTELA MULTI F oil**.
- Adjust steering knuckle bearing pre-load as instructed in the applicable Section.
- Upon wheel hub assembly, pack all pockets with **Fiat TUTELA G9 grease**; finally, fit back the side cover.

### **Kingpin bearing adjustments - Mods. 55-66DTF/60-66DTF/70-66DTF/80-66DTF.**

Proceed as instructed in text and illustrations on pages 2 and 3, Sect. 401 for Mods. 466 and 566.

### **Kingpin bearing adjustments - Mods. 45-66DTV and 55-66DTV**

Proceed as follows:

- Check bearing outer races fitted in axle housing and associated seals for wear; pack with **Fiat TUTELA G9 grease**.
- Remove lubricators from top and bottom covers.
- Install top cover (1, page 2) deprived of shims and tighten screws to specified torque.
- Install bottom cover (2, page 2) deprived of shims using three screws lubricated with engine oil.
- Tighten bottom cover screws in alternate sequence until the torque required to swing the knuckle carrier - checked with torque wrench applied to tool

## FRONT WHEEL DRIVE: Live Front Axle

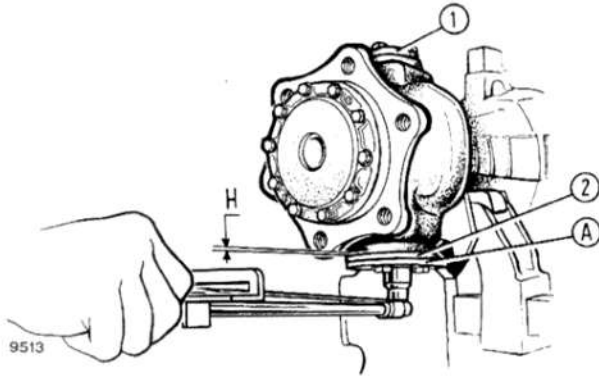

### Steering knuckle kingpin bearing pre-load adjustment shim thickness (S<sub>3</sub>, page 4, Sect. 402) - Mods. 45-66DTV/and 55-66 DTV.

A. Tool **292220/3** for knuckle carrier swing torque check - H. Specified clearance between carrier and bottom cover - 1. Top cover - 2. Bottom cover.

**292220/3** (A, page 2) is 18 to 22 Nm (1.8 to 2.2 kgm or 13 to 16 ft lb).

- Using a feeler gauge, measure the gap (H) between bottom cover and carrier alongside the screws.
- The arithmetical average of readings taken will provide the shim pack thickness (S<sub>3</sub>, page 4, Sect. 402) to be fitted under bottom cover.

Partially slacken bottom cover screws, insert the shims and tighten screws to specified torque.

Swing carrier several times for proper bedding; then, using a torque wrench applied to tool **292220/3** (A) check that the torque required to swing the carrier is 18 to 22 Nm (1.8 to 2.2 kgm or 13 to 16 ft lb).

Add or remove shims if torque is higher or lower than specified, respectively.  
Fit back lubricators in top and bottom covers and inject grease as required.

### Wheel hub bearings adjustment - Mods. 55-66DTF/60-66DTF/70-66DTF/80-66DTF

Proceed as instructed in text and illustrations on pages 4 and 5, Sect. 401 for Mods. 466DT and 566DT.

### Bevel drive differential unit servicing - Mods. 55-66DTF/60-66DTF/70-66DTF/80-66DTF

Proceed as instructed in text and illustrations on pages 7 and 8, Sect. 401 for Mods. 466DT and 566 DT.

### Bevel drive gear adjustment - Mods. 55-66DTF/60-66DTF/70-66DTF/80-66DTF

Proceed as instructed in text and illustrations on pages 8 thru 13, Sect. 401 for Mods. 466DT and 566DT.

### Bevel drive gear adjustment - Mods. 45-66DTV and 55-66DTV

#### 1. Bevel drive pinion assembly position adjustment and determination of associated shim thickness (S<sub>2</sub> page 4, Sect. 402) using universal gauge 293510 (Mods. 45-66DTV and 55-66DTV)

Proceed as follows:

- Install: bushings **293632** (B) and **293633** (D); also spacers **293625** (G) and **293619** (E) and **293620**

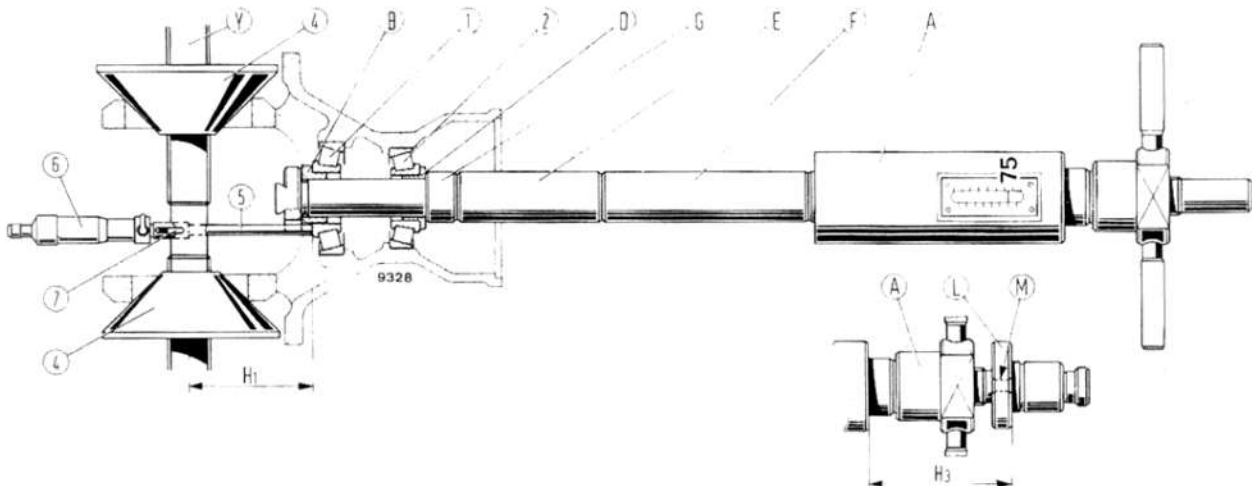

### Thickness determination: bevel pinion bearing spacer (S<sub>1</sub>, page 4, Sect. 401) and positioning shim (S<sub>2</sub>), using universal gauge 293510 - Mods. 45-66DTV/55-66DTV.

A. Universal gauge **293510** - B. Bushing **293632** - D. Bushing **293633** - E. Spacer **293619** - F. Spacer **293620** - G. Spacer **293625** - H<sub>1</sub>-H<sub>3</sub>. Dimensions to be measured using depth gauge - L. Register **293624** - M. Register holes - Y. 4, 5, 6 and 7. Fixture **293400/1** - 1.-2. Taper roller bearings.

(F, page 2) on universal gauge **293510** (A). Fit gauge in pinion bearing cage complete with taper roller bearings (1 and 2) already lubricated with engine oil.

- Turn gauge handwheel to bring pointer gradually to 75 kg (165 lb) on scale; at the same time, rotate gauge to bed in the bearings.
- Fit universal gauge **293400** (Y) on differential cages (without bearings).
- Operate on cones (4) until spindle (5) lines up with slot in item (B) and, consequently, bearing inner race (1).

**Note** - On depth gauge (6) fit spindle marked «75-100».

- Gradually tighten cones (4) - either manually or using ring nut spanner **293446** - and lock fixture in position by eliminating any end play.
- Lock gauge with screw (7) and measure dimension (H<sub>1</sub>).
- Establish correct nominal dimension (H<sub>2</sub>) between ring gear centerline and pinion back end:

$$H_2 = 98 \text{ mm} \pm C$$

where:

- 98 mm** = Nominal distance from ring gear centerline to back of pinion.
- C** = Correction factor marked on pinion, in mm, and preceded by + or - if other than 0, to be added to or subtracted from the nominal dimension (98 mm) according to the indicated sign.

— Thickness of shim (S<sub>2</sub>, page 4, Sect. 402) is given by:

$$S_2 = H_1 - H_2$$

where:

- H<sub>1</sub>** = Dimension read on depth gauge.
- H<sub>2</sub>** = Corrected nominal distance from ring gear centerline to back of pinion.

**Example:**

Depth gauge reading for H<sub>1</sub> = 98.5 mm  
Nominal dimension for H<sub>1</sub> = 98 mm  
Correction factor C = + 0.2 mm, then,  
Corrected nominal dimension H<sub>2</sub> = 98 + 0.2 mm  
Shim thickness S<sub>2</sub> = 98.5 - 98.2 = 0.3 mm  
If Correction factor C = - 0.2 mm, then,  
Corrected nominal dimension H<sub>2</sub> = 98 - 0.2 = 97.8 mm  
Actual shim thickness S<sub>2</sub> = 98.5 - 97.8 = 0.7 mm  
If correction factor C = 0 mm, then,  
Corrected nominal dimension H<sub>2</sub> = 98 mm  
Actual shim thickness S<sub>2</sub> = 98.5 - 98 = 0.5 mm

**2. Bevel drive pinion bearing adjustment and determination of associated shim thickness S<sub>1</sub>, page 4, Sect. 402) using universal gauge 293510 (Mods. 45-66DTV and 55-66DTV)**

Proceed as follows:

- After having determined shim thickness (S<sub>2</sub>) install on universal gauge (A, page 2) register **293624** (L) and line up holes (M) with flats on handwheel (detail a).
- Using a depth gauge, measure dimension (H<sub>2</sub>) thus obtained.

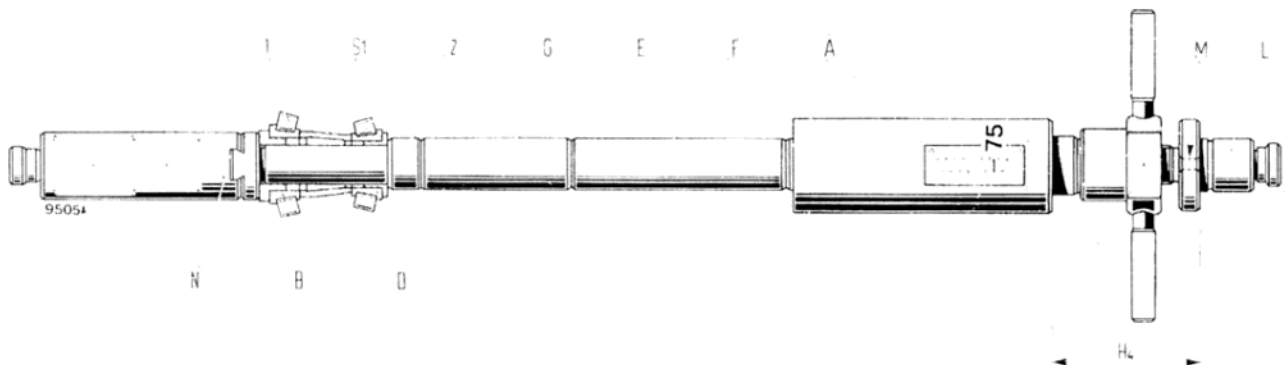

**Determining bevel pinion bearing spacer thickness (S<sub>1</sub>, page 4, Sect. 402) using universal gauge 293510.**

A. Universal gauge **293510** - B. Bushing **293632** - D. Bushing **293633** - E. Spacer **293610** - F. Spacer **293620** - G. Spacer **293625** - H. Dimension to be measured using depth gauge - L. Register **293624** - M. Register holes - N. Vise adapter **293617** - S. Spacer, bearing adjustment - 1 and 2. Bearing cones.

## FRONT WHEEL DRIVE: Live Front Axle

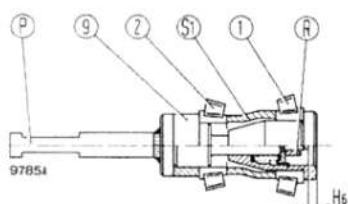
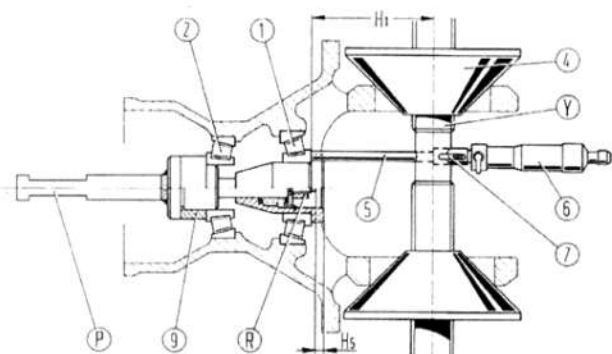

**Thickness determination: bevel pinion bearing spacer (S<sub>1</sub>, page 4, Sect. 402) and positioning shim using special purpose tool 293752 - Mods. 45-66DTV and 55-66DTV.**

H<sub>1</sub>, H<sub>s</sub>, H<sub>6</sub>. Dimensions to be measured using depth gauge - P. Special purpose tool 293752 - R. Tool nut - S<sub>1</sub>. Bearing adjustment spacer - Y., 4., 5., 6., and 7. Fixture 2934001/1 - 1, and 2. Taper roller bearings - 9. Spacer for tool 293752.

- Remove universal gauge (A, page 2), from pinion bearing cage and assemble on test bench, adding adapter 293617 (N, page 3) for fixing in vise; insert spacer (S<sub>1</sub>) on bevel drive pinion and bearing inner races (1 and 2), locating them as shown in Fig. on page 3.
- Bring gauge scale pointer back to 75 kg (165 lb) and, proceeding as directed earlier, determine dimension (H<sub>4</sub>, page 3).
- Bevel drive pinion bearing adjustment spacer thickness will be given by:

$$\text{Spacer thickness} = H_4 - H_3 + S_2$$

where:

**S<sub>2</sub>** = Bevel pinion positioning shim thickness established earlier.

If necessary, round off to the nearest 0.1 mm (0.004 in) up.

Print No. 603.54.228.02 - X - 1987

### 3. Bevel drive pinion positioning/bearing adjustment and associated shim (S<sub>1</sub> and S<sub>2</sub>, page 4, Sect. 402) thickness determination, using special purpose tool 293752 - Mods. 45-66DTV and 55-66DTV.

Proceed as follows:

- Install tool 293752 (P) with spacer (9) on pinion cage complete with taper roller bearings (1 and 2) already lubricated with some engine oil.
- Fully tighten nut (R) at same time turning the gauge to ensure proper bearing bedding.
- Fit universal gauge 293400 (Y) on differential carrier deprived of bearings.
- Turn in or out as required the gauge cones (4) to position spindle (5) in the direction of bearing inner race (1) thus eliminating any end play between cones (4) and differential bearing caps.

**Note** - On depth gauge (6) fit spindle marked 75 to 100.

- Lock gauge with screw (7) and measure dimension (H<sub>1</sub>).
- Establish correct nominal dimension (H<sub>2</sub>) between ring gear centerline and pinion back end.

$$H_2 = 98 \pm C$$

where:

**98 mm** = Nominal distance from ring gear centerline to back of pinion.

**C** = Correction factor marked on pinion, in mm, and preceded by + or - if other than 0, to be added to or subtracted from the nominal dimension (98 mm) according to the indicated sign.

- Thickness of shim (S<sub>2</sub>, page 4, Sect. 402) is given by:

$$S_2 = H_1 - H_2$$

where:

**H<sub>1</sub>** = Dimension read on depth gauge.

**H<sub>2</sub>** = Corrected nominal distance from ring gear centerline to back of pinion.

- After having determined thickness of shim ( $S_2$ ), using a depth gauge measure also distance ( $H_5$ , page 4) from top face to tool (P) plunger end.

Next, proceed as follows:

- Remove tool (P, page 4) from bevel pinion bearing cage and assemble on test bench adding adjustment spacer ( $S_1$ , page 4) on bevel pinion and adjustment shims for bearings (1 and 2) located as shown in Figure on page 4..
- Tighten nut (R, page 4) fully in then measure (distance  $H_6$ ) with depth gauge.
- Bevel drive pinion bearing adjustment spacer thickness will be:

$$\text{Spacer thickness} = H_5 - H_6 + S_2$$

where:

$S_2$  = Bevel pinion positioning shim thickness established earlier.

If necessary, round off to the nearest 0.1 mm (0.004 in) up.

#### 4. Differential bearing adjustments and bevel drive backlash check

Proceed as follows:

- With assembled bevel pinion, install differential unit in carrier making sure that ring gear does not force on pinion, tighten bearing cap screws ( $C_{10}$ ) to 59 Nm (6 kgm or 43.4 ft lb), then slacken and re-tighten to 20 Nm (2 kgm or 14.5 ft lb).
- Lubricate ring gear bearings, rotate bevel drive set while tightening LH ring nut ( $G_s$ , page 6, Sect. 402) using special spanner **293544** until a torque of 1.8-2.3 Nm (0.18 to 0.24 kgm or 13 to 17 ft lb) is obtained: check this condition by winding a string around ring gear retaining screws and pulling with a spring balance (dynamometer). The specified revolving torque is equivalent to a force of 24 to 34 Nm (2.5 to 3.5 kg or 5.5 to 7.7 lb) read on balance.
- Determine ring gear backlash by applying a dial gauge (reading to 1/100) perpendicularly to the outer face of a ring gear tooth.
- Repeat the measurement in other two offset positions, 120° apart, and compare the average value of the three readings taken with the specified nominal value of 0.15 to 0.20 mm (0.06 to 0.008 in) averaging 0.18 mm (0.007 in).

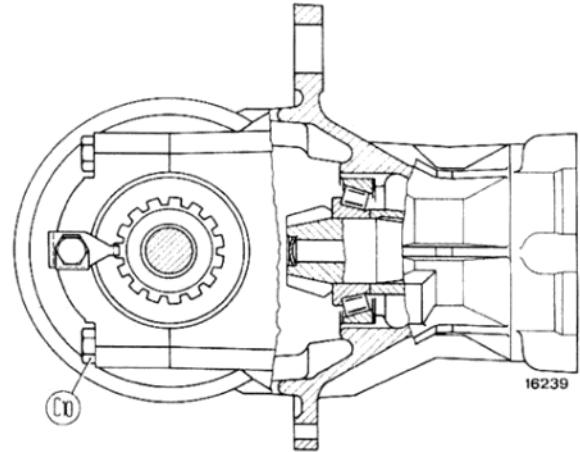

#### Differential bearing adjustment and bevel drive backlash checks.

$C_{10}$ . Differential carrier bearing cap screws.

If backlash value falls outside the specified tolerance range, back off one ring nut and turn in the other by the same amount to restore axial pre-load and obtain specified backlash.

#### Axle center swing pivot pin installation - Mods. 45-66DTV and 55-66DTV.

Upon installation of axle articulation pivot, lubricate inner surfaces (A) of bushings press fitted in axle housing with **Fiat TUTELA MULTI F oil**. Fit shim packs (S) under retaining screw heads as required to provide the specified clearance (G) of 0.6 to 0.8 mm (0.024 to 0.031 in).

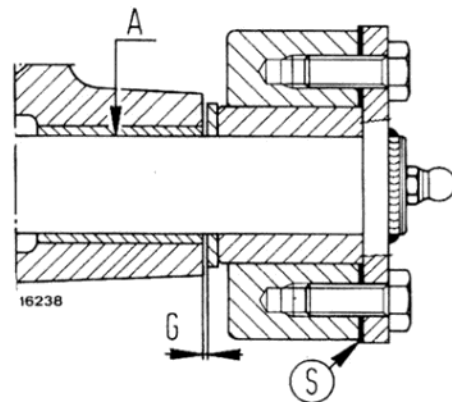

#### Axle center swing pivot pin installation - Mods. 45-66DTV and 55-66DTV.

A. At assembly, lubricate bush bore surfaces with **Fiat TUTELA MULTI F oil** - G. = 0.6 to 0.8 mm or 0.024 to 0.031 in) - S. Shim packs (single shim thickness = 0.2 mm 0.008 in).

***FRONT WHEEL DRIVE:***

## **DRIVE SHAFT**

### **Removal**

Mods. 45-66DTV and 55-66DTV

For U-jointed drive shaft removal, proceed as follows:

- Take off the two shaft guards.
- Back off the two screws securing shaft to the axle bevel drive pinion and to axle drive splined input shaft, then turn in the U-jointed shaft until it uncouples from axle bevel pinion.

Mods. 55-66DTF/60-66DTF/70-66DTF/80-66DTF

For drive shaft removal, proceed as follows:

- Back off center bearing screws (C<sub>12</sub>, page 1, Sect. 402, for mods. 55-66DT/60-66DT/70-66DT/80-66DT) remove retaining rings (28 and 31) from their seats and pull out drive shaft (30), shifting splined sleeves (27 and 33) inwards.

### **Installation**

Mods. 45-66DTV and 55-66DTV

For U-jointed shaft installation, proceed as follows:

- Fit shaft rear end first on axle drive housing driven shaft then the shaft front end onto the front axle bevel pinion.
- Turn in shaft to adjust its length which is correct when the two retaining bolts (31 and 32, page 4) fit exactly into their respective seats in bevel pinion and in axle drive input shaft.

Mods. 45-66DTF/60-66DTF/70-66DTF/80-66DTF

Re-install drive shaft in respective seats and adjust as follows:

- Bring axle housing into full contact with axle pivot rear support (25, Sect. 402, for Mods. 55-66DT/60-66DT/70-66DT/80-66DT) to take up any support end play; position front splined sleeve (27) against retaining ring (28). Using a feeler gauge, measure the gap formed between sleeve and retaining ring (26), then install shim (S<sub>s</sub>) to provide a sleeve end play (L) of 1 to 1.5 mm (0.04 to 0.06 mm).

## **AXLE DRIVE**

### **Removal**

For axle drive removal from tractor, proceed as follows.

- Remove the drive shaft as instructed in previous paragraph.
- Drain oil from rear drive housing and, preferably, also from front axle drive housing.
- Disconnect vertical link from outer lever, back off screws (C<sub>13</sub>) and take down axle drive housing.

Disassemble the drive unit on bench as follows:

- Remove roll pin (45) using a suitable punch, pull out intermediate shaft (46) and remove associated gear (48) along with needle roller bearing (47) and thrust washers.
- From outside of axle drive housing remove dust ring (38), seal (39), retaining ring (40) and driven shaft (43) with attached ball bearing and oil slinger.
- From axle drive housing, take out FWD control sleeve (50) driven gear (42) complete with thrust washers.

- Take out ball bearing (44) by first removing axle drive housing rear cover (Mods. 45-66DTV and 55-66DTV) or by using a suitable slide hammer puller (Mods. 55-66DTF/60-66DTF/70-66DTF/80-66DTF). Check ball bearing efficiency and thrust washers for wear.

If necessary, scrap and replace seal (39) using protector **293836** during installation.

### **Installation**

Reverse the removal procedure sequence and refer to the Figures on pages 2, 3 and 4.

Preferably fit a new dust ring (38) taking care to prevent distortion during assembly.

Before front axle drive housing installation on rear drive housing, accurately clean and degrease mating faces and apply a 2 mm (0.08 in) thick bead of jointing compound as shown in Figure on page 1, Sect. 402 for Mods. 466/566/666/766.

For jointing compound grades, refer to page 6, Sect. A - Mods. 466/566/666/766.

# FRONT WHEEL DRIVE: Sections

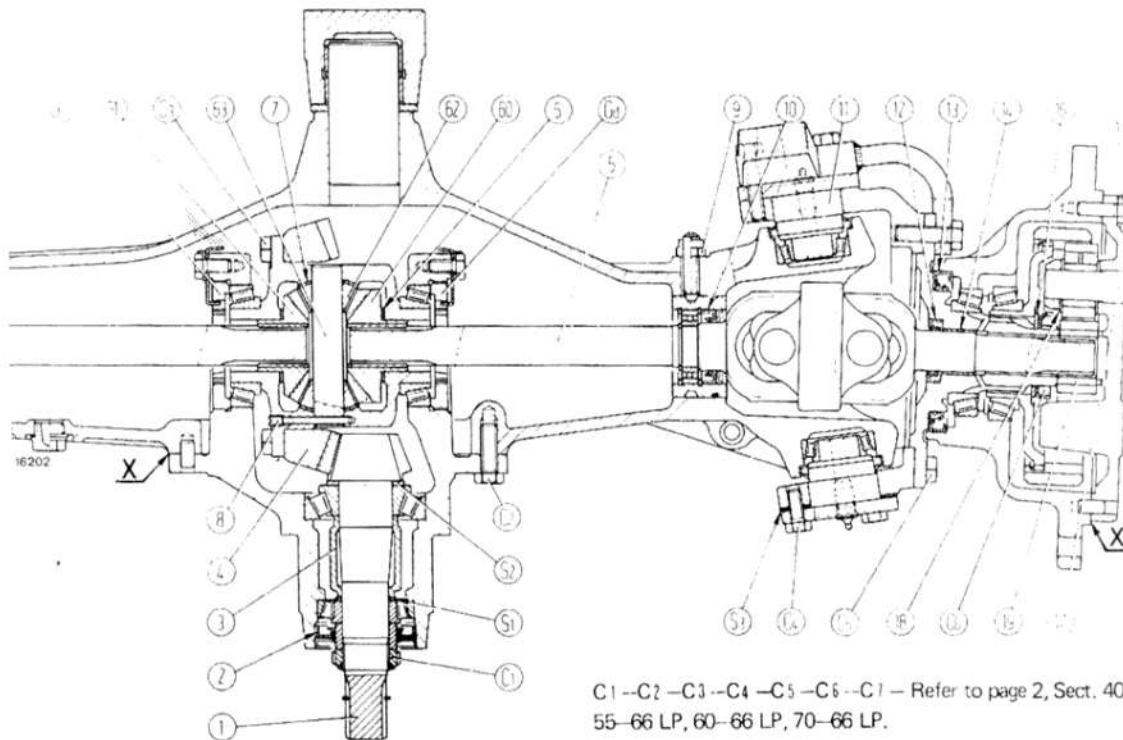

C1 - C2 - C3 - C4 - C5 - C6 - C7 - Refer to page 2, Sect. 40, models 55-66 LP, 60-66 LP, 70-66 LP.

### Live front axle section - Mod. 55-66 DTF.

**Note** - On assembly, thoroughly clean and degrease mating faces **X** and apply one of jointing compounds listed on page 6, Sect. A, for Mods. 466/566/666/766.

**Important** - For front axle center swing pivot section refer to illustration and legend on page 1, Sect. 402 for Mods. 55-66DT/60-66DT/70-66DT/80-66DT. For axle drive assy section refer to illustration and legend on page 2, Sect. 402, for Mod. 45-66.

C1. Bevel pinion bearing ring nut - C2. Differential carrier screw

- C3. Bevel ring gear screw - C4. King pin screws - C5. Steering knuckle screw - C6. Wheel hub bearing ring nut - C7. Final drive housing screw - Gd and Gs. R.H. and L.H. differential bearing ring nuts - S1. Bevel pinion bearing shim - S2. Bevel pinion position shim - 1. Bevel pinion - 2. Seal - 3. Bevel pinion bearing spacer - 4. Ring gear - 5. Axle shaft with universal joint - 6. Side gear washers - 7. Differential pinion washers - 8. Differential pinion journal screw - 9. Bearing cage screw - 10. Seal - 11. King pin bearing - 12 and 13. Seals - 14. Axle shaft bushings - 16. Thrust washer - 17. Final drive planet wheel journals - 18. Final drive planet wheel shims - 19. Final drive sun gear - 60./61. Differential side gears - 62. Differential pinion - 63. Differential pinion journal.

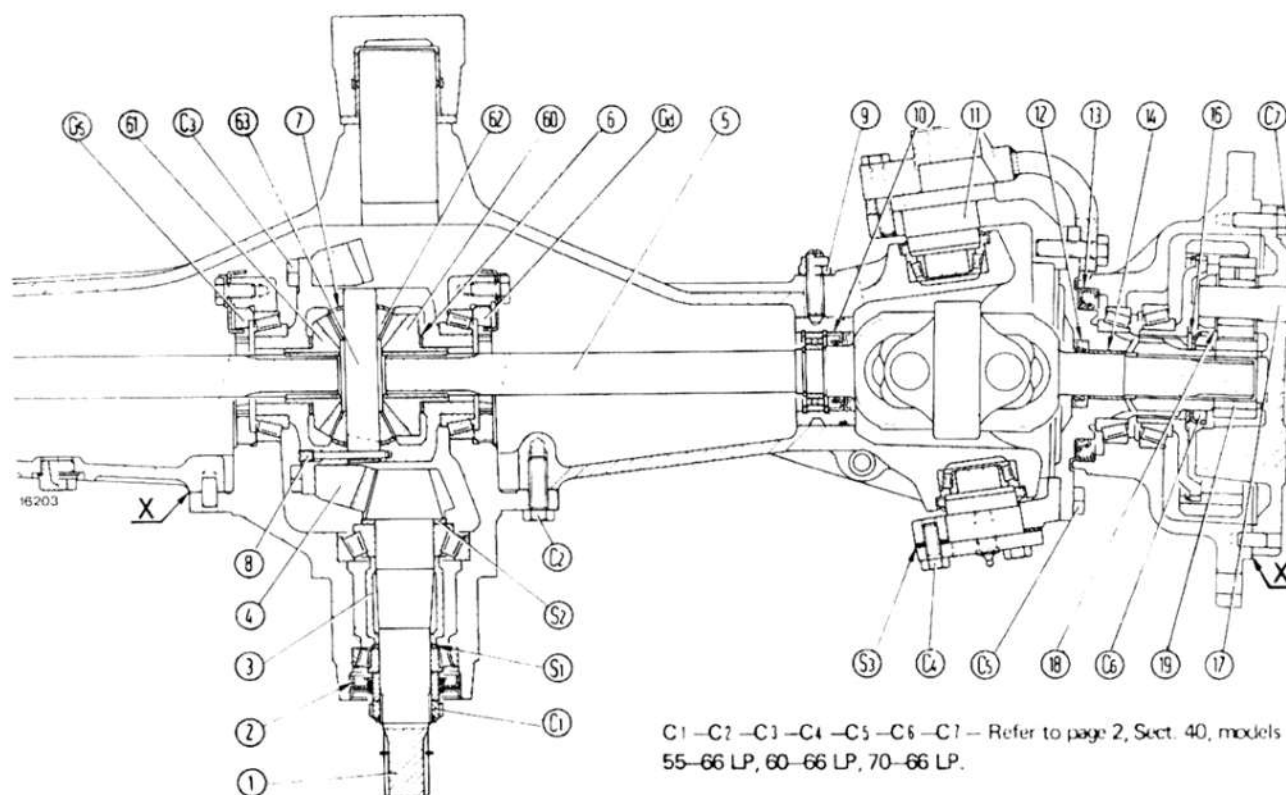

**Live front axle section - Mods. 60-66DTF/70-66DTF/  
80-66DTF.**

**Note** - On assembly, thoroughly clean and degrease mating faces **X** and apply one of the jointing compounds listed on page 6, Sect. A, for Mods. 466/566/666/766.

**Important** - For the sections through front axle center swing pivot, axle drive housing and axle drive shaft, refer to illustration and legend on page 1, Sect. 402, for Mods. 55-66DT/60-66DT/70-66DT/80-66DT.

C1. Bevel pinion bearing ring nut - C2. Differential carrier screw  
- C3 Bevel ring gear screw - C4. King pin screws - C5. Steering

C1 - C2 - C3 - C4 - C5 - C6 - C7 - Refer to page 2, Sect. 40, models  
55-66 LP, 60-66 LP, 70-66 LP.

knuckle screw - C6. Wheel hub bearing ring nut - C7. Final drive housing screw - Gd./Gs. RH and LH differential bearing ring nuts - S1. Bevel pinion bearing shim - S2. Bevel pinion positioning shim - 1. Bevel pinion - 2. Seal - 3. Bevel pinion bearing spacer - 4. Bevel ring gear - 5. Axle shaft with universal joint - 6. Side gear washers - 7. Differential pinion washers - 8. Differential pinion journal to case screw - 9. Bearing cage screw - 10. Seal - 11. King pin bearing - 12. and 13. Seals - 14. Axle shaft bushings - 16. Thrust washer - 17. Final drive planet wheel journals - 18. Final drive planet wheel shims - 19. Final drive sun gear - 60./61. Differential side gears - 62. Differential pinion - 63. Differential pinion journal.

# FRONT WHEEL DRIVE: Sections

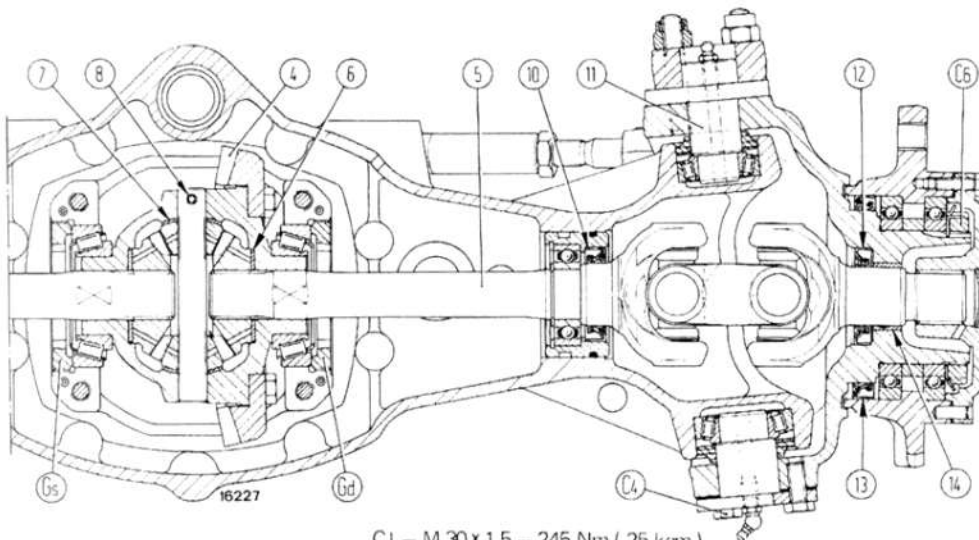

- C1 - M 30 x 1,5 - 245 Nm ( 25 kgm )  
 C2 - M 10 x 1,5 - 40 Nm ( 4,1 kgm )  
 C3 - M 10 x 1,25 - 61 Nm ( 6,2 kgm )  
 C4 - M 10 x 1,5 - 40 Nm ( 4,1 kgm )  
 C4 - M12 x 1,75 - 65 Nm ( 6,7 kgm )  
 C5 - M 85 x 2 - 392 Nm ( 40 kgm )

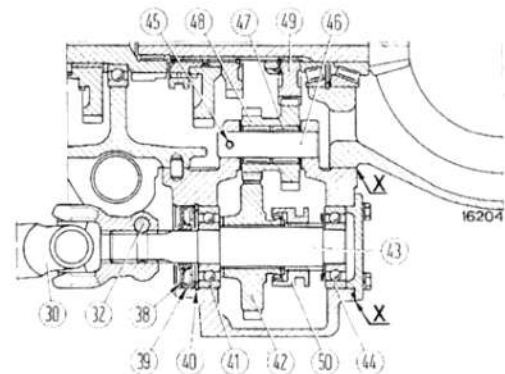
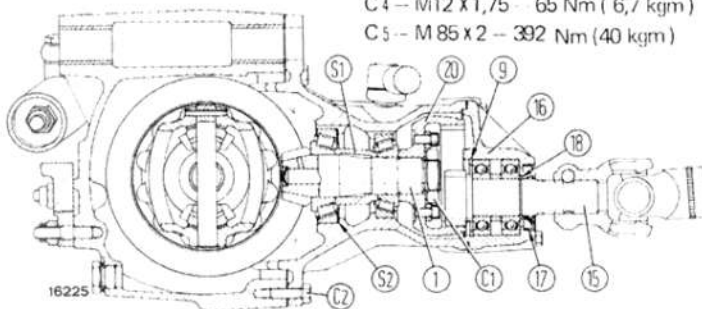

## Longitudinal sections through live front axle, center swing pivot, axle drive and drive shaft - Mods. 45-66DTV and 55-66DTV.

**Note** - On assembly, thoroughly clean and degrease mating faces X and apply one of the jointing compounds listed on page 6, Sect. A, for Mods. 466/566/666/766.

C1. Bevel pinion bearing ring nut - C2. Differential carrier screw - C3. Bevel ring gear screw - C4. King pin screws - C5. Wheel hub bearing ring nut - Gd/Gs. RH and LH differential bearing ring nuts - S1. Bevel pinion bearing adjustment spacer - S2. Bevel pinion positioning shim - S3. King pin bearing shims - 1. Bevel pinion - 4. Bevel ring gear - 5. Axle shaft with universal joint - 6. Side gear washers - 7. Differential pinion washers - 8. differential pinion journal to case screw - 10. Seal - 11. King pin bearing - 12. and 13. - Seals - 14. Axle shaft bushings - 15. Final drive pinion - 16. Flange - 17. Seal - 18. and 19. Retaining rings - 20. Final drive ring gear - 30. U-jointed drive shaft - 31. and 32. Bolts - 34. Shoe - 35. Inner relay lever - 36. Plunger - 37.

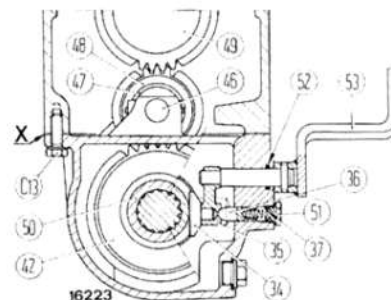

Spring - 38. Dust ring - 39. Seal - 40. Retaining ring - 41. Ball bearing - 42. Driven gear - 43. Splined driven shaft - 44. Ball bearing - 45. Roll pin - 46. Intermediate shaft - 47. Needle roller bearing - 48. Intermediate gear - 49. Drive gear keyed on bevel pinion - 50. FWD engagement sleeve - 51. Plug - 52. O-ring - 53. Axle drive control lever - 60./61. Side gears - 62. Differential pinion - 63. Differential pinion journal.

**LIFT ADJUSTMENTS - MODS. 45-66V/55-66V/  
55-66F**

The following adjustments refer to a lift deprived of its hydraulic control valve and installed on a work bench or secured to a rotary service stand through a suitable bracket.

If carried out, adjustments must follow the description order.

With lift installed on tractor, only lift arm upward travel adjustments are possible.

**1. Position control adjustment - Mods. 45-66V/  
55-66V/55-66F.**

Proceed as follows:

- Locate outer position control lever (5) fully forward against limit spacer.
- Rotate cross shaft to bring inner arm in contact with lift body.
- Using wrench **293844/1** (C) slacken associated jam nut (10) and back off travel adjusting screw (6) until screw is no longer in contact with control valve lever (7).
- Install tool **293846** (A) on lift body.
- Using two wrenches, unscrew jam nut (8) and turn in or out adjustable link rod (9) so that plunger (P) is perfectly in line with outer register (R<sub>1</sub>) of tool (A).

**Note** - This condition corresponds to a gap (L<sub>1</sub>) of 82 to 82.1 mm (3.22 to 3.23 in) between lever (7) and lift body front face measured by applying a force (F<sub>1</sub>) of 4 to 4.5 daN (kg) (9 to 10 lb) to lever end.

- Tighten jam nut (8).
- Rotate cross shaft to bring piston fully forward and check that plunger (P<sub>1</sub>) of tool **293846** is retracted by 1.3 to 1.7 mm (0.0512 to 0.0670 in) with respect to register (R<sub>2</sub>) of same tool.

**Note** - This condition corresponds to a gap (L<sub>1</sub>) of 86.3 to 86.7 mm (3.398 to 3.413 in) between lever end and lift body front face, measured by applying a force of 4 to 4.5 daN (kg) (9 to 10 lb) to lever end.

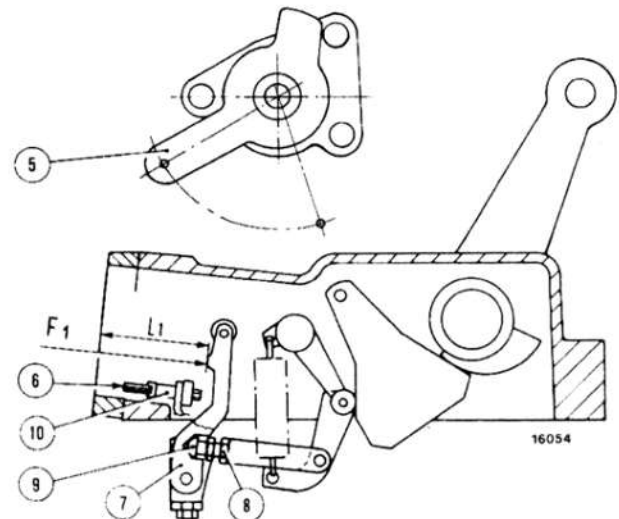

**Lift position control adjustment - Mods. 45-66V/55-66V/  
55-66F.**

F<sub>1</sub> = 4 to 4.5 daN (kg) (9 to 10 lb). Force applied by tool **293846** on lever (7) - L<sub>1</sub>: Distance between end of lever (7) and lift body front face - 5. Outer position control lever - 6. Travel limit adjusting screw - 7. Control valve lever - 8. Jam nut - 9. Adjustable link rod - 10. Travel limit adjusting screw socket head jam nut.

**2. On-bench max lift arm travel adjustment - Mods.  
45-66V/55-66V/55-66F**

Proceed as follows:

- With tool **293846** (A) installed on lift body, fit connection **293872** (D).
- Locate outer position control lever (5) fully forward against limit spacer.

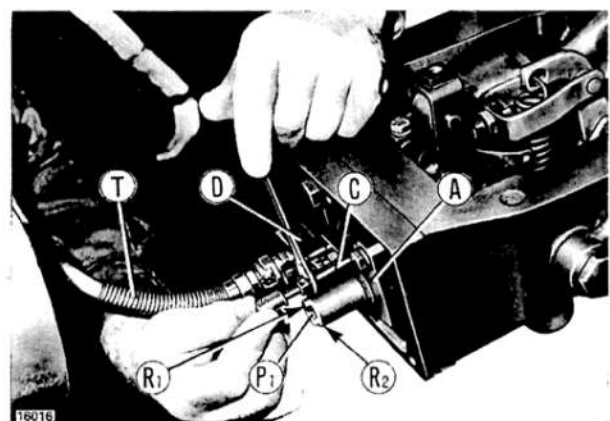

**On-bench adjustment of max lift arm travel - Mods.  
(45-66V/55-66V/55-66F).**

A. Tool **293846** - C. Wrench **293844/1** - D. Connection **293872** - P<sub>1</sub>: Plunger of tool (A) - R<sub>1</sub>: Outer register, tool (A) - R<sub>2</sub>: Inner register tool (A) - T. Compressed air line.

# HYDRAULIC LIFT UNIT: Lift

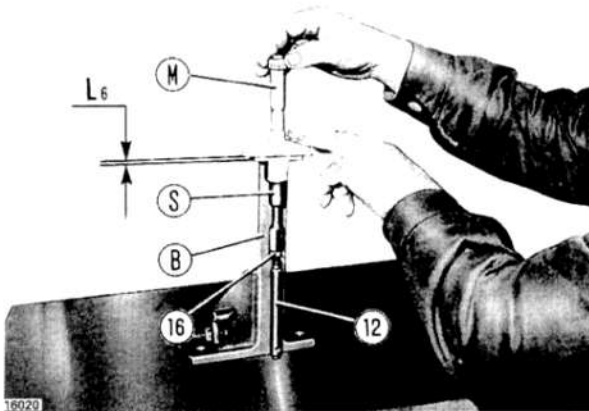

Zeroing tool 292541 (B) for draft control adjustment - Mods. 45-66V/55-66V/55-66F.

L<sub>6</sub>. Gap between top of spindle (S) and depth gauge support face - M. Depth gauge - S. Spindle for tool 292541 - 12. Draft control rod - 16. Jam nut.

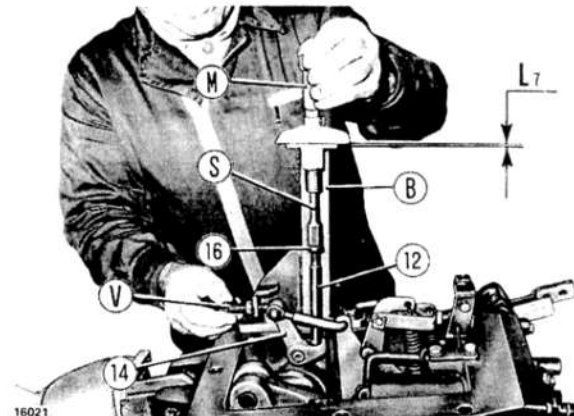

Draft control adjustment - Mods. 45-66V/55-66V/55-66F.

B. Tool 292541 - L<sub>7</sub>. Gap between spindle top face and tool face resting on depth gauge - M. Depth gauge - S. Spindle, tool 292541 - V. Screw, tool 292541 - 12. Draft control rod - 14. Draft control inner lever - 16. Jam nut.

- Rotate cross shaft to bring inner arm in contact with lift body.
- Couple connection 293872 (D, page 1) to Shop compressed air source (T) and introduce air in cylinder barrel so that piston is forced to move its full lift stroke and maintain air pressure to hold piston in this position.
- Using wrench 293844/1 (C) turn in screw (6, page 1) until the end of plunger (P<sub>1</sub>) is retracted by 1.3 to 1.7 mm (0.0512 to 0.0670 in) with respect to register (R<sub>2</sub>, page 1) of tool 293846 (A).

**Note** - This condition corresponds to a gap (L<sub>1</sub>) of 86.3 to 86.7 mm (3.398 to 3.413 in) between end of lever (7) and lift body front face.

- Lock socket head jam nut (10).

### 3. Draft control adjustment - Mods. 45-66V/55-66V/55-66F

Proceed as follows:

- Remove end piece of draft control rod (12) and fit on spindle (S) of tool 292541 and secure by jam nut (16).
- Place tool 292451 (B) complete with its spindle (S) and end piece of draft control rod (12) on a surface plate and measure gap (L<sub>6</sub>) between spindle top face and face of depth gauge resting on tool (always turn in rod 12 onto spindle so that the spindle face is in all cases retracted a few mm with respect to the depth gauge resting face).

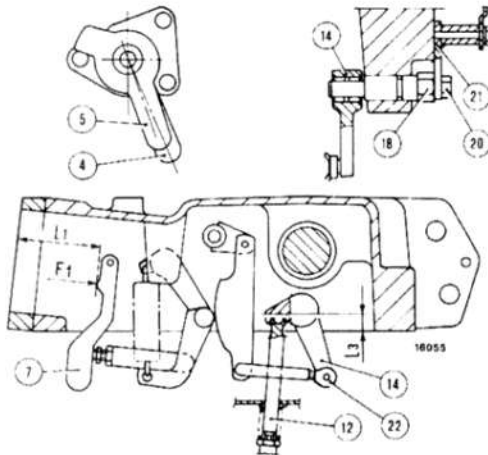

### Draft control adjustment - Mods. 45-66V/55-66V/55-66F.

F<sub>1</sub>. 4 to 4.5 daN (kg) (9 to 10 lb). Force applied to lever (7) by tool 293846 - L<sub>1</sub> = 81.9 to 82.1 mm (3.22 to 3.23 in). Distance between end of lever (7) and lift body front face - L<sub>3</sub> = 22.9 to 23.1 mm (0.901 to 0.909 in). Distance between lift body mating face at drive housing and face of rod (12) in contact with lever (14) - 4. Draft control outer lever - 5. Position control outer lever - 7. Control valve actuating lever - 12. Draft control rod - 14. Draft control inner lever - 18. Cam pin - 20. Screw - 21. Bracket - 22. Draft control adjustable link.

- With tool **293846** (A, page 1) installed on lift body and disconnected from Shop compressed air source, move both draft control and position control outer levers (4 and 5, page 2) fully back against respective limit spacers.

Next:

- Locate cam pin (18, page 2) securing the draft control inner lever, in a horizontal position with cam side facing lift body rear end.
- Install tool **292541** (B, page 2) on lift body and secure to two housing holes as shown (see Fig. on page 2). Turn screw (V) to move draft control inner lever (14) until the end of plunger (P<sub>1</sub>, page 1) is located as near as possible to inner register (R<sub>2</sub>) of tool **293846** (A).
- Rotate slightly cam pin (18, page 2) to retract as far back as possible the end of the plunger of tool **293846**.
- By means of screw (V, page 2) operate on draft control inner lever (14) until the end of plunger is brought in line with inner register (R<sub>2</sub>) of tool **293846** (A, page 1).
- Finally, turn cam pin (18, page 2) some more until the end of plunger is located in line with outer register (R<sub>1</sub>, page 1).
- Insert the spindle of tool **292541** (B, page 2) in the seat provided in draft control inner lever (14).
- With plunger of tool **293846** set in line with outer register (R<sub>1</sub>) turn as required the adjustable link (22, page 2) then measure with depth gauge (M, page 2) distance (L<sub>7</sub>) between spindle top face and gauge face resting on tool **292541**.
- Distance (L<sub>7</sub>, page 2) shall be:

$$L_7 = L_6 + L_3$$

where:

- L<sub>6</sub>** = Distance measured with tool **292541** on a surface plate.
- L<sub>3</sub>** = **22.9 to 23.1 mm (0.901 to 0.090 in)**. Distance between lift body mating face at drive housing and face of rod (12, page 2) in contact with lever (14).

**Note** - This condition corresponds to a distance (L<sub>1</sub>, page 2) of 81.9 to 82.1 mm (3.22 to 3.23 in) between end of lever (7) and lift body front face, measured by applying a force of 4 to 4.5 daN (9 to 10 lb) to lever (7).

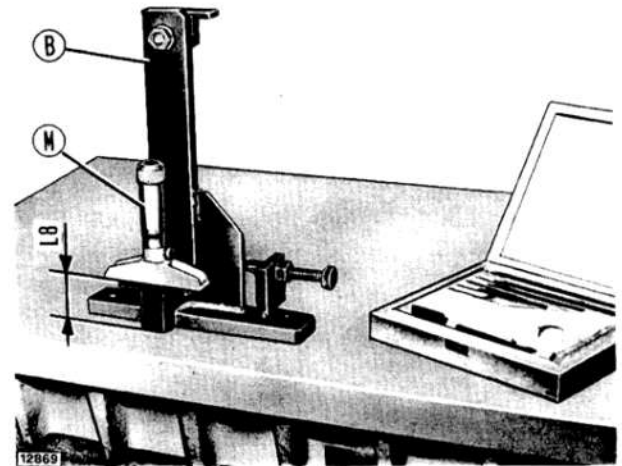

**Zeroing tool 292541 (B) for draft control adjustment - Mods. 45-66V/55-66V/55-66F.**

L<sub>6</sub>. Distance between tool rest face on surface plate and depth gauge rest face on tool (this dimension shall be marked on tool)  
- M. Depth gauge.

**IMPORTANT** - Check that with plunger (P<sub>1</sub>) exactly in line with outer register (R<sub>1</sub>) of tool **293846** (A) distance (L<sub>7</sub>, page 2) is as follows:

$$L_7 = L_6 + L_3$$

where:

- L<sub>6</sub>** = Distance measured with tool **292541** on a surface plate.
- L<sub>3</sub>** = **22.9 to 23.1 mm (0.901 to 0.903 in)**. Distance between lift body mating face at drive housing and face of rod (12) in contact with lever (14).

Should these conditions fail to check, turn as required cam pin (18, page 2) and knurled screw (V) of tool **292541** until specified conditions are met.

- Turn in screw (20, page 2) so that cam pin (18) is locked with bracket (21).
- Remove tools **293846** and **292541** and fit hydraulic control valve on lift body.

Next, install lift unit on tractor, proceeding as described in the following paragraphs.

**IMPORTANT** - First place tool **292541** on a surface plate and, using depth gauge (M), measure distance (L<sub>8</sub>) between tool rest face on plate and depth gauge rest face on tool.  
This dimension (L<sub>8</sub>) shall be marked on tool.

# HYDRAULIC LIFT UNIT: Lift

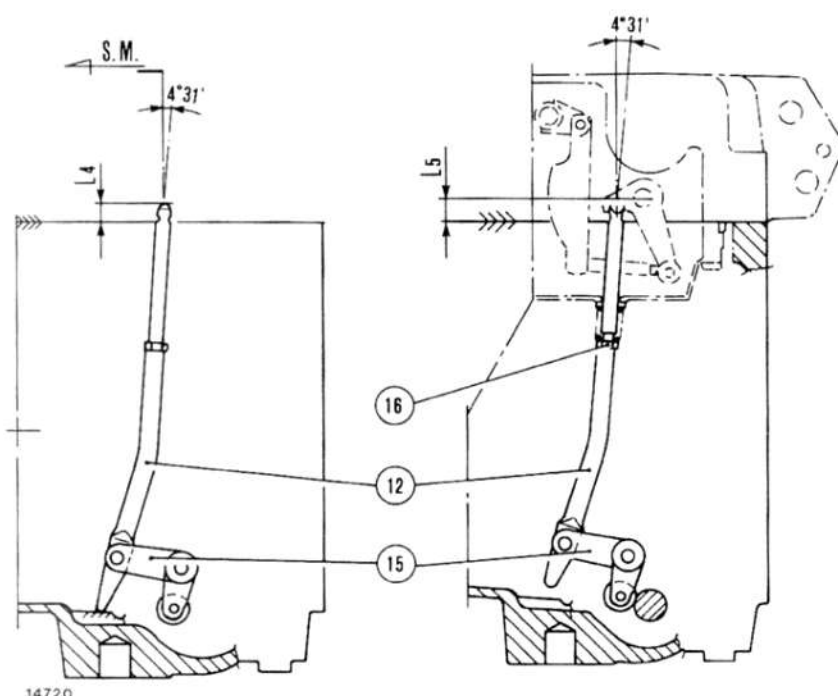

### Draft control adjustment - Mods. 45-66V/55-66V/55-66F.

L<sub>4</sub>. Proudness of rod (12) top end over drive housing top face (sensing bar removed) - L<sub>5</sub>. Proudness of rod (12) top end over drive housing top face (sensing bar installed) - S.M. Travel direction - 12. Draft control rod - 15. Draft control relay lever - 16. Jam nut.

- Install relay lever (15, page 8) with draft control rod (12) on rear drive housing.
- Rest relay lever (15) on the stop provided in rear drive housing, then install tool **292541** securing it to two housing holes in such a way that draft control rod (12) fits perfectly into hole on tool as shown below.
- Using depth gauge (M) measure distance (L<sub>9</sub>) between top of rod (12) and face of depth gauge resting on tool.

**Note** - Proudness (L<sub>4</sub>) of rod (12) top end over drive housing top face (with sensing bar removed) will be given by:

$$L_4 = L_8 - L_9$$

where:

L<sub>8</sub> and L<sub>9</sub> = Dimensions measured with tool **252541** placed on surface plate (L<sub>8</sub>, page 3) or on drive housing (L<sub>9</sub>).

- Install the sensing bar and measure the new distance (L<sub>10</sub>) between rod (12) top end and face of depth gauge resting on tool.

**Note** - Proudness (L<sub>5</sub>) of rod (12) top end over drive housing top face (with sensing bar installed) will be given by:

$$L_5 = L_8 - L_{10}$$

where:

L<sub>8</sub> and L<sub>10</sub> = Dimensions measured with tool **292541** placed on surface plate (L<sub>8</sub>, page 3) or on drive housing (L<sub>10</sub>).

- Check that dimension (L<sub>5</sub>) exceeds (L<sub>4</sub>) by not less than 5 mm (0.20 in).

- Slacken jam nut (16) and adjust the length of draft control rod to obtain a new proudness (L<sub>5</sub>) determined on tool **292541** - over drive housing top face as follows:

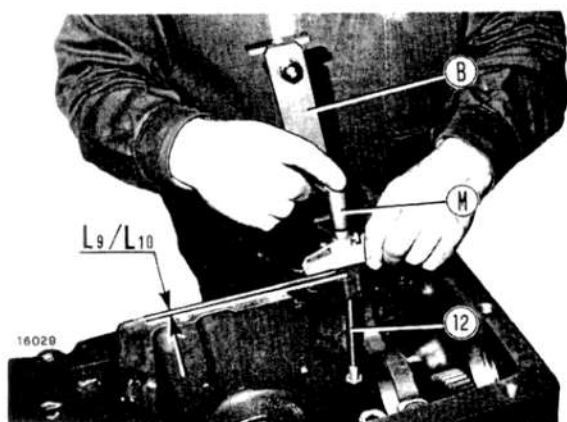

### Draft control adjustment.

B. Tool **293541** - L<sub>9</sub>. Distance from top of rod (12) to depth gauge face resting on tool (sensing bar removed) - L<sub>10</sub>. Distance from top of rod (12) to depth gauge face resting on tool (with sensing bar installed) - M. Depth gauge - 12. Draft control rod.

**Adjusting position and draft control rod linkage - Mods. 45-66V/55-66V/55-66F.**

F. Draft control lever -  $L_{13} = 15$  mm (0.59 in). Clearance between end of quadrant slot and stalk rearmost edges of levers (F and P) -  $L_{14} = 165$  to 175 mm (6.5 to 6.9 in). Clearance between slot front end and front most edge of lever (F) - Position control lever - h. Draft control outer relay lever - 5. Position control outer relay lever.

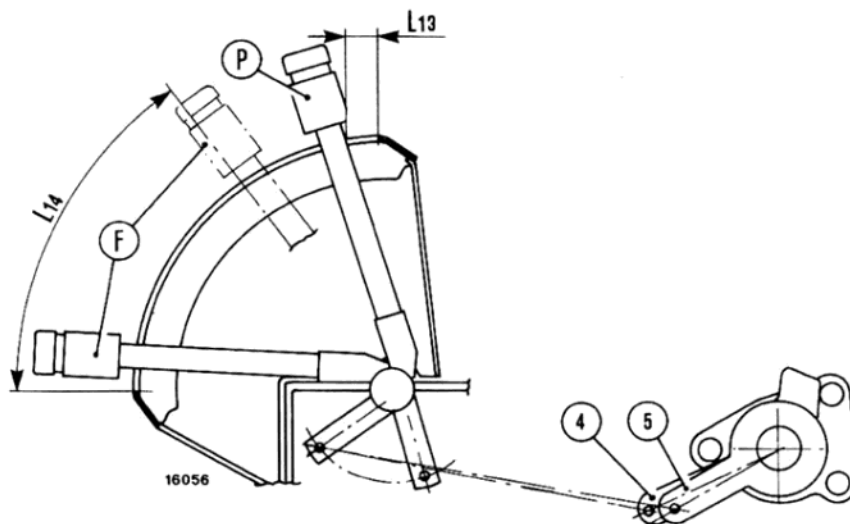

$$L_5 = L_8 - L_{11}$$

where:

$L_8$  = Dimension measured with tool **292541** placed on surface plate.

$L_{10} = 18.3$  to  $18.5$  mm (**0.720** to **0.728** in). Proudness of rod end (12, page 8) above drive housing top face.

- Tighten jam nut (16) and install lift unit on tractor.

**Position control rod linkage adjustment - Mods. 45-66V/55-66V/55-66F**

Proceed as follows:

- Set position control lever (P) upright on quadrant and check clearance ( $L_{13}$ ) to be 15 mm (0.59 in) between stalk rearmost edge and slot end.
- Locate position control outer relay lever (5) fully forward against its limit spacer.
- Connect link rod and adjust its length by turning in or out as required its end pieces.
- Lock the jam nuts.

**Draft control rod linkage adjustment - Mods. 45-66V/55-66V/55-66F**

Proceed as follows:

- Move position control lever (P) fully forward on quadrant (all down).
- Move outer relay lever (4) fully forward against limit spacer.

- Position draft control lever (F) at a clearance ( $L_{13}$ ) of 15 mm (0.59 in) from slot end to lever stalk rearmost edge.

- Connect draft control link rod.

- Start engine and keep running at average speed.

- Then, without applying any load to lift arms, check that lifting under draft control begins at a travel ( $L_{14}$ ) of 165 to 175 mm (6.5 to 6.9 in) between start of slot and lever stalk front edge. If this does not check, operate on cam pin (18, page 2) until the specified value is ensured. Lock screw (20, page 2).

**LIFT-O-MATIC adjustment - Mods. 45-66V/55-66V/55-66F**

Proceed as follows:

- Locate draft and position control levers (F and P, respectively) fully forward on quadrant.

- Connect cable to pushbutton (11, page 6) then secure the LIFT-O-MATIC device on mudguard.

- Start engine and accelerate to average speed.

- Connect cable to lever (13, page 6) adjusting its length so that, upon actuation of button (11) lift arms start to lower when button is still short of its full stroke by a distance  $L_{16}$  of 9 to 12 mm (0.35 to 0.47 in).

# HYDRAULIC LIFT UNIT: Lift

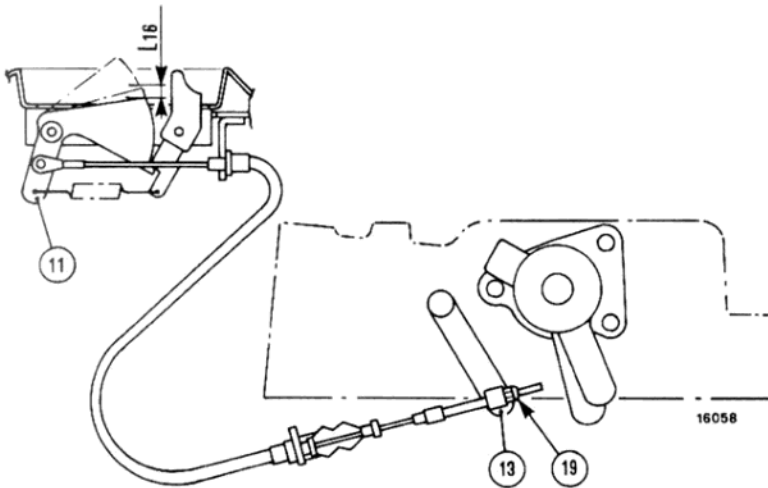

### LIFT-O-MATIC adjustment - Mods. 45-66V/55-66V/55-66F.

$L_{16}$  = 9 to 12 mm (0.35 to 0.47 in).  
Button (11) residual stroke - 11. Lift-O-Matic control button - 13. Lift-O-Matic control lever - 19. Control cable end piece.

### 4. On-Tractor max lift arm travel adjustment - Mods. 45-66V/55-66V/55-66F.

Proceed as instructed in text and illustrations on page 11, Sect. 501 for Mod. 45-66.

### LIFT ADJUSTMENTS FOR TRACTOR MODS. 60-66F/70-66F/80-66F.

The following adjustments refer to a lift deprived of its hydraulic control valve and installed on a work bench or secured to a rotary service stand through a suitable bracket.

If carried out, adjustments must follow the description order.

With lift installed on tractor, only lift arm upward travel adjustments are possible.

Throughout operations, the Lift-O-Matic device shall be excluded (outer control lever locked in vertical position) unless otherwise stated.

### 1. Position control adjustment - Mods. 60-66F/70-66F/80-66F

Proceed as instructed in text and illustrations on pages 2 and 3, Sect. 501 for Mods. 55-66LP/60-66LP/70-66LP.

### 2. On-bench max lift arm travel adjustment - Mods. 60-66F/70-66F/80-66F

Proceed as instructed in text and illustrations on page 2, Sect. 501 for Mods. 55-66LP/60-66LP/70-66LP.

### 3. Draft control adjustment - Mods. 60-66F/70-66F/80-66F

Proceed as instructed in text and illustrations on pages 3 thru 6, Sect. 501 for Mods. 55-66LP/60-66LP/70-66LP.

### 4. Position control rod linkage adjustment - Mods. 60-66F/70-66F/80-66F

Proceed as follows:

- Set position control lever (P, page 7) upright on quadrant and check clearance ( $L_{12}$ ) to be 11 mm (0.43 in) between stalk rearmost edge and slot top end.
- Locate position control outer relay lever (37, page 7) fully forward against its limit spacer.
- Connect link rod and, if necessary, adjust its length to obtain distance ( $L_{12}$ , page 7) of 11 mm (0.43 in).
- Lock rod in position by the jam nuts.

### 5. Draft control rod linkage adjustment - Mods. 60-66F/70-66F/80-66F

Test conditions:

- No additional load on lift arms.
- Engine accelerated to medium rpm rate.

Next, proceed as follows:

- Move position control lever (P, page 7) fully forward on quadrant (all down).
- Move draft control outer relay lever (38, page 7) all back against its limit spacer.
- Set draft control lever (F, page 7) at a distance ( $L_{13}$ ) of 12 mm (0.47 in) from slot start to lever stalk front-most edge.
- Connect draft control link rod; if necessary, adjust its length and make sure that distance ( $L_{13}$ ) equals 12 mm (0.47 in) as specified.

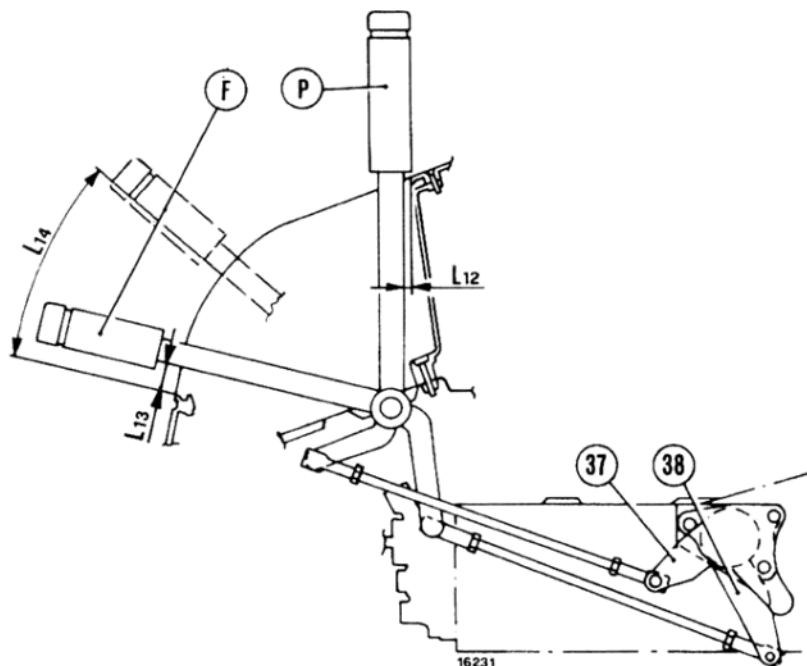

**Adjusting position (P) and draft (F) control levers.**

F. Draft control lever -  $L_{12}$  = 11 mm (0.43 in). Distance between position control lever (P) and beginning of quadrant slot -  $L_{13}$  = 12 mm (0.47 in). Distance between draft control lever (F) and beginning of quadrant slot -  $L_{14}$  = 165 to 175 mm (6.5 to 6.9 in). Distance between beginning of quadrant slot (bottom end) and stalk front edge of lever (F) - P. Position control hand lever - 37. Position control outer relay lever on lift unit - 38. Draft control outer relay lever on lift unit.

- Set draft control lever (F) at a distance  $L_{14}$  = 165 to 175 mm (6.5 to 6.9 in) from beginning of quadrant slot. Check that with lever set in this position, full lifting of arms begins.
- If this does not occur, operate on cam pin (32) as required to obtain the specified distance.
- Lock cam pin (32) by threaded dowel (31) and lock washer (33).

**6. LIFT-O-MATIC adjustment - Mods. 60-66F/70-66F/80-66F**

Proceed as instructed in text and illustrations on pages 7 and 8, Sect. 501 for Mods. 55-66LP/60-66LP/70-66LP.

**7. On-tractor max lift arm travel adjustment - Mods. 60-66F/70-66F/80-66F.**

Proceed as instructed in text and illustrations on page 8, Sect. 501 for Mods. 55-66LP/60-66LP/70-66LP.

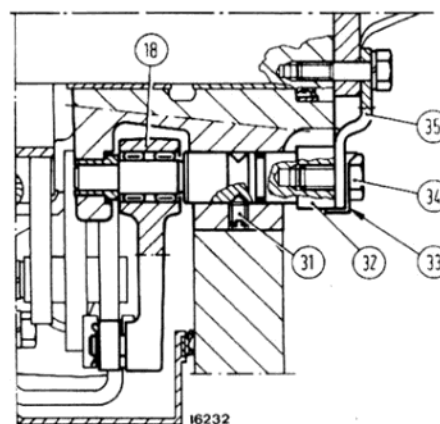

**Section through draft control inner lever (18) pivot point.**

31. Threaded dowel pin - 32. Cam pin, for lever (18) - 33. Lock washer - 34. Screw - 35. Bracket.



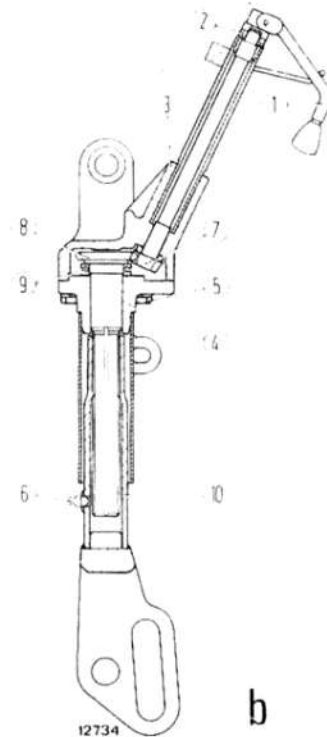
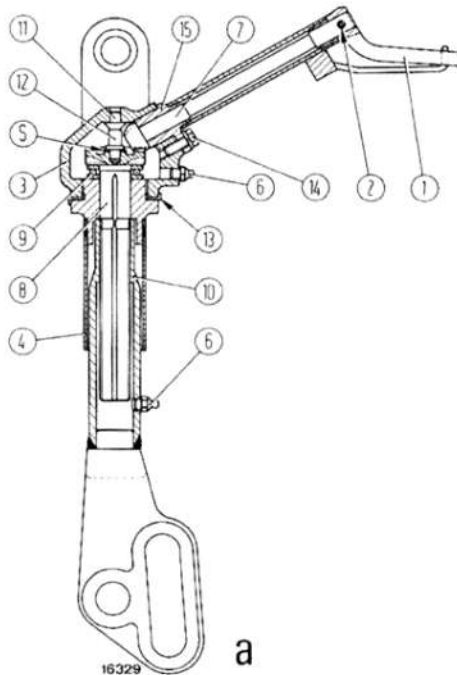

**Section through RH lifting rod.**

a. Mods. 45-66V/55-66V - b. Mods. 60-66F/70-66F/80-66F - S. End float shims - 1. Levelling box handle - 2. Roll pin - 3. Upper housing - 4. Cover - 5. Cover screws - 6. Grease fitting - 7. Drive pinion - 8. Driven gear - 9. Thrust bearing - 10. Lower housing - 11. Fixed pin - 12. Driven gear pin - 13. Lock washer - 14. Drive pinion support screws - 15. Drive pinion support.

**Right-hand lifting rod**

To remove the RH lifting rod on Mods. 45-66V/55-66V/55-66F proceed as follows:

- Straighten the tab of lockwasher (13) unscrew cover (4) with attached driven gear (8).
- Back out screw (14), remove support (15) with drive pinion (7).
- Back off lower housing (10) then remove driven gear and thrust bearing (9).
- Take off roll pin (2) and remove handle (1) and drive pinion.

At assembly, pack with **Fiat TUTELA G9 or other approved grease** the pockets in upper and lower housings;

next, insert shims (S) between pin (12) and driven gear (8) to obtain an end float of 0.1 to 0.3 mm (0.004 to 0.012 in). Measure end float by introducing a feeler gauge between pins (11) and (12).

To remove the RH lifting rod on Mods. 60-66F/70-66F/80-66F proceed as follows:

- Remove screws (5) and take off cover (4) together with driven gear (8).
- Back off lower housing (10) and remove driven gear and thrust bearing (9).
- Take off roll pin (2) and remove handle (1), followed by the drive pinion.

At assembly, pack with **Fiat TUTELA G9 or other approved grease** the pockets in upper and lower housings.

## HYDRAULIC LIFT UNIT: Implement Attachment

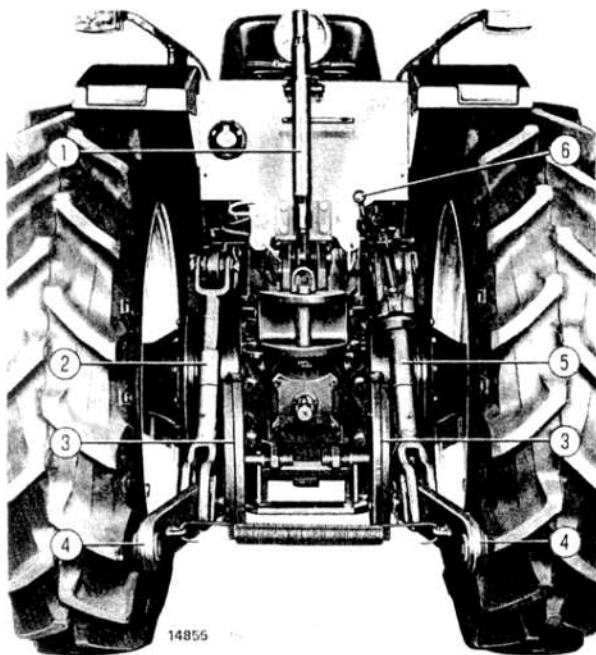

a

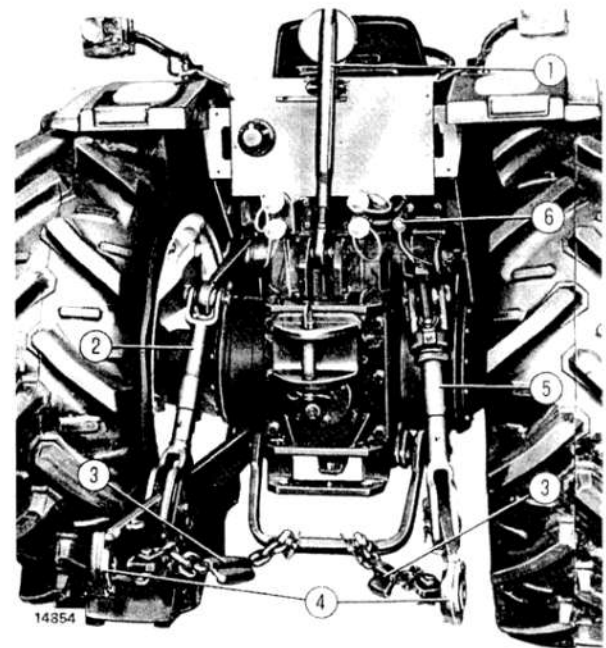

b

### Lift and implement attachment.

a. Mods. 56-66V/55-66V (Cat. 1) - b. Mod. 55-66F (Cat. 1-2) - 1. Adjustable top link - 2. LH lifting rod - 3. Lower link sway limiting blocks (Mods. 45-66V/55-66V - Fig. a) or chains (Mod. 55-66F - Fig. b) - with implements attached - 4. Lower links - 5. R.H. lifting rod - 6. RH lifting rod levelling box handle and spring.

### Lift and implement attachment.

1. Adjustable top link - 2. L.H. lifting rod - 3. Lower links sway limiting rod (with implements attached) - 4. Lower links - 5. Pin, top link to support - 6. R.H. lifting rod - 7. RH lifting rod levelling box handle and spring.

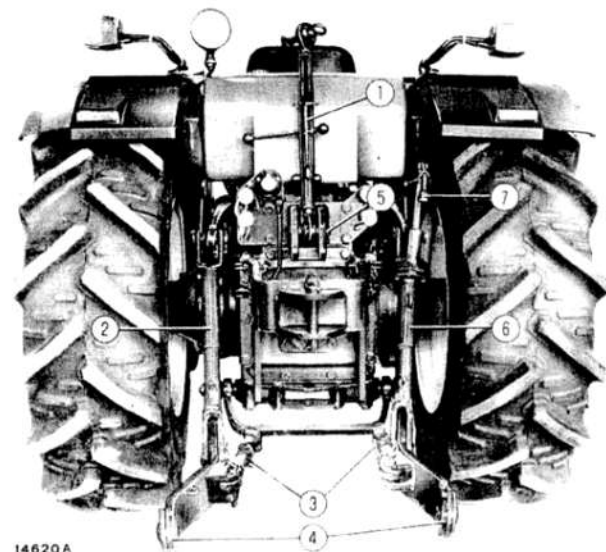

14620A

**BATTERY CHARGE SYSTEM**

Refer to text on page 1, Sect. 60, for Mods. 55-66/60-66/70-66/80-66.

**MARELLI OR BOSCH STARTER MOTORS**

See page 2, Sect. 60, for Mods. 55-66 and 60-66.

**BATTERY**

Voltage . . . . .	12 Volts
Nominal capacity (at 20-hr discharge rate) . . . . .	88 Ah for normal or dry charge units Alternative: 90 Ah w/sealed units

**FUSES**

Six 8 Amp and two 16 Amp fuses, housed in box.		
Fuses	PROTECTED CIRCUITS	Amp
1	Engine stopping solenoid.	8
2	Turn signal and stop lights (tractor and trailer) with indicators, water temperature gauge, fuel gauge, air cleaner restriction indicator, battery charge indicator, low engine oil pressure indicator, parking brake indicator and sending unit, horn.	8
3	Front R.H. parking light, rear L.H. parking light, license plate light, trailer L.H. parking light, parking light indicator.	8
4	Front L.H. parking light, rear R.H. parking light, trailer R.H. parking light, rear work light, instrument panel light.	8
5	Low beams	8
6	High beams and indicator.	8
7	Hazard warning indicator and flasher, power point.	16
8	Thermostarter.	16

**STARTER SWITCH** - See Table on page 2, Sect. 60, for Mods. 55-66/60-66/70-66/80-66.

**LIGHTING SWITCH** - See Table on page 14, Sect. 60, for Mods. 466/566/666/766.

**TRACTOR AND TRAILER TURN SIGNAL LIGHT SWITCH** - See Table on page 14, Sect. 60, for Mods. 466/566/666/766.

**INSTRUMENT PANEL** - See illustration and legend on page 3, Sect. 60, for Mods. 55-66/60-66/70-66/80-66.

# ELECTRICAL SYSTEM: Wiring Diagram

## WIRING DIAGRAM TRACTOR RS 45-66V/55-66V/55-66F WITH ACCESSORIES

Note - Detail shows installation of the optional thermostarter.

● To starter switch connection 15/54

1. Headlamps, high/low beams
2. Battery
3. Alternator
4. Low engine oil pressure sending unit
5. Horn
6. Dry air cleaner restriction sending unit
7. Fuel gauge sending unit
8. Starter
9. Hazard warning and turn signal electronic flasher
10. Multi-function instrument panel:
  - a. Battery charge indicator (red)
  - b. Low engine oil pressure indicator (red)
  - c. Dry air cleaner restriction indicator (red, optional)
  - d. Parking brake indicator (red)
  - e. Spare
  - f. Parking lights indicator (green)
  - g. High beam indicator (blue)
  - h. Tractor turn signal indicator (green)
  - i. 1st trailer turn signal indicator (green)
  - l. 2nd trailer turn signal indicator (green)
  - m. Water temperature gauge
  - n. Fuel gauge
11. Water temperature gauge sending unit
12. Starter switch
13. Turn signal switch
14. Lighting switch and horn button
15. Engine stopping solenoid
16. Parking brake flasher with indicator
17. Hazard warning switch with indicator
18. Single conductor power point
19. Fuse box
20. Front parking and turn signal lights
21. Starter inhibitor switch
22. Parking brake indicator sending unit
23. Stop light switch
24. Rear parking, turn signal and stop lights
25. License plate light
26. Rear work light and switch
27. Seven conductor power point
28. Thermostarter control button (optional)
29. Thermostarter (optional)

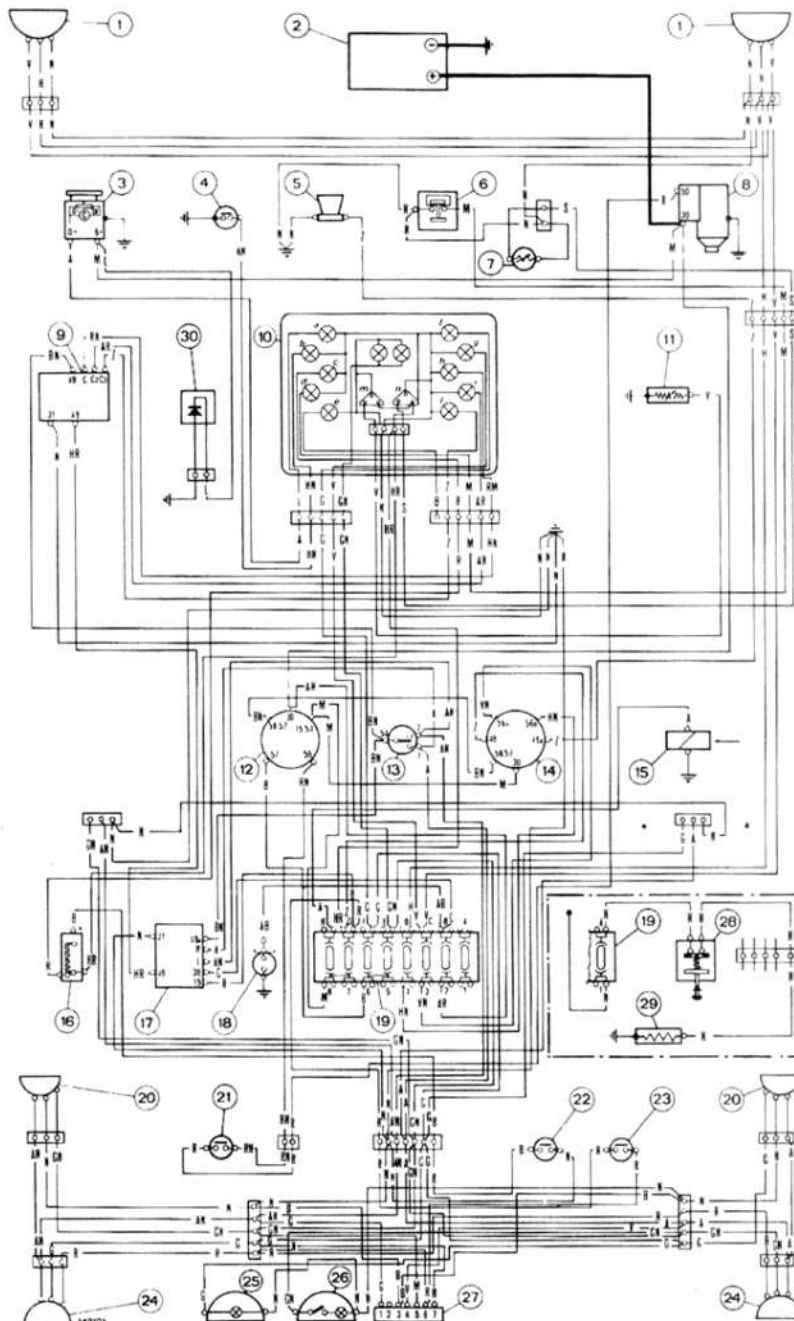

### CABLE COLOUR CODE

A = Light blue	M = Brown
B = White	N = Black
C = Orange	R = Red
G = Yellow	S = Pink
H = Grey	V = Green
L = Dark blue	Z = Mauve

**10 - ENGINE**

**100 - Removal - Installation - Bench test.**

**101 - Engine block - Cylinder head.**

**102 - Valve Gear**

**103 - Crank Gear**

**104 - Fuel system**

**106 - Cooling system**

● **Mod. 45-66V:** Tools listed on pages 1 and 2, Sect. 90 fr Mod. 45-66 apply.

● **Mods. 55-66V/55-66F/60-66F/70-66F/80-66F:** Tools listed on pages 1 and 2, Sect. 90, for Mods. 55-66/60-66/70-66/80-66 apply.

**20 - POWER TRAIN**

**201 - Clutch**

**202 - Transmission and Splitter**

**204 - Bevel gear and differential**

**205 - Brakes**

**206 - Final Drives**

**207 - Power Take Off**

● **Mods. 45-66V/55-66V/55-66F:** Tools listed on page 2, Sect. 90, for Mod. 45-66 apply.

● **Mods. 60-66F/70-66F/80-66F:** Tools listed on page 2, Sect. 90, for Mods. 55-66/60-66/70-66/80-66 apply.

**30 - FRONT AXLE - STEERING**

**303 - Hydrostatic power steering**

Tools listed on page 3, Sect. 90, for Mods. 55-66/60-66/70-66/80-66 apply.

**40 - FRONT WHEEL DRIVE**

**401 - Live front axle**

● **Mods. 45-66DTV and 55-66DTV**

**293460 (322215)** Service stand, front axles.

**293836** Protector, drive shaft seal installation.

**293743** Support, differential bevel pinion housing.

**293651** Guard, final drive shaft seal.

**293400/1** Fixture, bevel pinion position checks (use with items **293732** or **293510**).

**293510** Universal gauge, bevel pinion shaft bearing adjustments.

**293752** Tool, special purpose, bevel pinion shaft bearing adjustments.

**293544** Spanner, special, differential cage bearings adjustments.

**293655** Spanner, special, front wheel hub bearings ring nut.

**292220/3** Tool steering knuckle carrier swing torque checks.

● **Mods. 55-66DTF/60-66DTF/70-66DTF/80-66DTF**

**293782** Tool, retainer, bevel drive pinion (use with item **293785**)

**293785** Spanner, special, bevel drive pinion ring nut (use with item **293782**).

**293743** Support, bevel drive pinion housing.

**293460 (322215)** Service stand, front axles.

**293836** Protector, drive shaft seal installation.

**293520/2** Wrench, bevel pinion bearing ring nut and rolling torque checks.

**293400/1** Fixture, bevel pinion position checks (use with **293732** or **293510**).

**293510** Universal gauge, bevel pinion shaft bearing adjustments.

**293438/2** Adjuster, bevel pinion bearing.

**293544** Spanner, special, differential bearing ring nut.

**293837** Spanner, special, wheel shaft bearing ring nut.

**292220/3** Tool, steering knuckle carrier swing torque checks.

**291525** Locating pins, side final drive cover installation.

**293812** Locating pins, front wheel installation.

**50 - HYDRAULIC LIFT UNIT**

**501 - Lift**

● **Mods. 45-55V/55-66V/55-66F** - Tools listed on page 3, Sect. 90, for Mod. 45-66 apply.

● **Mods. 60-66F/70-66F/80-66F** - Tools listed on pages 3 and 4, Sect. 90, for Mods. 55-66 and 60-66 apply.

**502 - Hydraulic pump.**

Tools listed on page 4, Sect. 90, for Mods. 55-66/60-66/70-66/80-66 apply.

**504 - Remote control valves.**

Tools listed on page 4, Sect. 90, for Mods. 55-66/60-66/70-66/80-66 apply.

**60 - ELECTRICAL SYSTEM**

Tools listed on page 4, Sect. 90, for Mods. 55-66/60-66/70-66/80-66 apply.

**SERVICE TOOLS**

# **FIAT**

## **Trattori**

**55-66 LP    55-66 DT LP**  
**60-66 LP    60-66 DT LP**  
**70-66 LP    70-66 DT LP**

### **WORKSHOP MANUAL**

#### **QUICK REFERENCE INDEX**

	Section
<b>GENERAL</b> . . . . .	<b>A</b>
<b>SPECIFICATIONS</b> . . . . .	<b>00</b>
<b>ENGINE</b> . . . . .	<b>10</b>
<b>POWER TRAIN</b> . . . . .	<b>20</b>
<b>FRONT AXLE</b> <b>— STEERING</b> . . . . .	<b>30</b>
<b>FRONT WHEEL DRIVE</b> . . . . .	<b>40</b>
<b>HYDRAULIC LIFT UNIT</b> . . . . .	<b>50</b>
<b>ELECTRICAL SYSTEM</b> . . . . .	<b>60</b>
<b>SERVICE TOOLS</b> . . . . .	<b>90</b>

**S E R V I Z I   T E C N I C I   D I   A S S I S T E N Z A**

---

**FIAT TRATTORI S.p.A. - Viale delle Nazioni, 55 - S. Matteo - 41100 MODENA - Italy**

Servizi Tecnici di Assistenza - Pubblicazioni Tecniche - Print No. **603.54.228.02** - X - 1987 - 2000 - MUCCHI

Print No. **603.54.228.02** - X - 1987

	Page	Date		Page	Date
<b>A - GENERAL</b>					
General instructions - See Mods. 466/566/666/766	6-7	VII-1984	Cylinder head - See Mods. 55-66/60-66/70-66	2-3-4	IX-1985
Safety precautions - See Mods. 466/566/666/766	8-9-10	VII-1984	<b>102 - ENGINE - Valve gear</b>		
<b>00 - SPECIFICATIONS</b>					
Identification data - Weights	1	X-1987	Camshaft - Valves, guides and springs - See Mods. 55-66/60-66/70-66	1	IX-1985
Engine	1	X-1987	Tappets, pushrods and rockers - See Mods. 55-66/60-66/70-66	1	IX-1985
Power train - Brakes - Steering - Front axle - Live front axle - Rear Wheels - Power take-off	2	X-1987	Valve timing gears - See Mods. 466/566/666/766	3	VII-1984
Hydraulic lift - Towing attachments - Front axle ballasting - Body	2	X-1987	<b>103 - ENGINE - Crank gear</b>		
Electrical system	3	X-1987	Crankshaft - See Mods. 55-66/60-66/70-66	1	IX-1985
Lighting equipment - Instruments and accessories - See Mods. 50-66/60-66/70-66/80-66	7	IX-1987	Main/Big end bearings and caps: See Mods. 466/566/666/766	2-3	VII-1984
Tire sizes - Main dimensions	3	X-1987	Pistons and rings - See Mods. 55-66/60-66/70-66	1-2	IX-1985
Power train schematics	4-5	X-1987	Connecting rods - See Mods. 55-66/60-66/70-66	2	IX-1985
Fluid capacities	6	X-1987	Flywheel - See Mods. 466/566/666/766	5	VII-1984
<b>10 - ENGINE: Specifications and Data</b>					
Engine block - Cylinder head - See Mods. 55-66/60-66/70-66	1	IX-1985	Dynamic balancer Mod. 70-66LP: See Mod. 70-66	2	VII-1984
Crank gear - See Mods. 55-66/60-66/70-66	2-3-4-5	IX-1985	<b>105 - ENGINE - Lubrication system</b>		
Valve gear - See Mods. 55-66/60-66/70-66	5-6-7	IX-1985	55-66LP/60-66LP engine lubrication system schematics - See Mods. 466 and 566	1	VII-1984
Lubrication system - See Mods. 55-66/60-66/70-66	8	IX-1985	70-66LP engine lubrication system schematics - See Mod. 666	2	VII-1984
Cooling system - See Mods. 55-66/60-66/70-66	8-9	IX-1985	Oil pump - Oil filter - Low oil pressure warning indicator - See Mods. 466/566/666/766	3	VII-1984
Fuel system - See Mods. 55-66/60-66/70-66	9 thru 16	IX-1985	<b>106 - ENGINE - Cooling system</b>		
Torque Data - See Mods. 55-66/60-66/70-66	19-20	IX-1985	Coolin system schematics - See Mods. 55-66/60-66/70-66	1	IX-1985
Engine section - Mods. 55-66LP/60-66LP - See Mods. 55-66/60-66	21	IX-1985	Description - See Mods. 466-566-666-766	2	VII-1984
Engine sections - Mod. 70-66LP - See Mod. 70-66	22	IX-1985	Water pump - See Mods. 55-66/60-66/70-66/80-66	2	IX-1985
<b>100 - ENGINE - Description - Performance Data - Removal - Installation</b>					
Description - See Mods. 55-66/60-66/70-66/80-66	1	IX-1985	Radiator - See Mods. 466/566/666/766	3	VII-1984
Performance Data - See Mods. 55-66/60-66/70-66/80-66	1-2	IX-1985	Drive belt tension adjustments - See Mods. 55-66/60-66/70-66/80-66	2	IX-1985
Compression Test - See Mods 466/566/666/766	4		Water temperature gauge - Thermostat - See Mods. 466/566/666/766	4	VII-1984
Removal - Installation - See Mods. 466/566/666/766	4-5		<b>20 - POWER TRAIN - Specifications and Data</b>		
<b>101 - Engine - Engine block - Cylinder head</b>					
Barrel liners - See Mods. 55-66/60-66/70-66	1-2	IX-1985	Clutches	1	IX-1985
<b>Fiat Trattori</b>					

# GENERAL: Contents

	Page	Date		Page	Date
Brakes - See Mods. 55-66/60-66 . . . .	2	IX-1985	<b>207 - POWER TRAIN - Power Take Off</b>		
Side final drives . . . . .	2	X-1987	Removal - Installation - See Mods. 466/ 566/666/766 . . . . .	1-2	VII-1984
Power Take Off . . . . .	2	X-1987	Disassembly - Assembly - See Mods. 466/566/666/766 . . . . .	1-2	VII-1984
Torque Data . . . . .	2	X-1987	PTO longitudinal section - See Mods. 466/566/666/766 . . . . .	2	VII-1984
Power train cross-section . . . . .	3	X-1987			
Power train longitudinal section . . . .	4	X-1987			
<b>201 - POWER TRAIN - Clutch</b>			<b>30 - FRONT AXLE - STEERING: Specifications and Data</b>		
Removal - Installation - See Mods. 466/ 566/666/766 . . . . .	1-2	VII-1984	Front axle . . . . .	1	X-1987
VALEO Clutch servicing . . . . .	1	X-1987	Hydrostatic power steering . . . . .	1-2	X-1987
LUK clutch servicing . . . . .	1	X-1987	Torque Data - See Mods. 466/566/666/ 766 . . . . .	5	VII-1984
OMG clutch servicing . . . . .	1	X-1987			
Clutch control linkage adjustments . . .	1-2	X-1987	<b>301 - FRONT AXLE - STEERING: Dead front axle</b>		
<b>202 - POWER TRAIN - Transmission and splitter</b>			Axle removal/installation Steering knuckle servicing - See Mods. 466/ 566/666/766 . . . . .	1-2	VII-1984
Removal and installation - See Mods. 55-66/60-66/70-66/80-66 . . . . .	2	IX-1985	Front wheel geometry checks - See Mods. 466/566/666/766 . . . . .	2	VII-1984
Disassembly - See Mods. 55-66/60-66/ 70-66/80-66 . . . . .	2-3-4	IX-1985			
Transmission/Splitter longitudinal and cross sections . . . . .	1	X-1987	<b>303 - FRONT AXLE - STEERING: Power steering</b>		
Inspection - Assembly - See Mods. 55-66/60-66/70-66/80-66 . . . . .	4	X-1987	Power steering servicing - See Mods. 466/566/666/766 . . . . .	1	VII-1984
<b>203 - POWER TRAIN - Creeper and mechanical reverser</b>			Power cylinder servicing - See Mods. 55-66/60-66/70-66/80-66 . . . . .	1	IX-1985
Creeper: Description - Servicing - See Mods. 466/566/666/766 . . . . .	1-2-3	VII-1984	Hydraulic pump and reservoir servic- ing - Hydraulic system bleeding - See Mods. 55-66/60-66/70-66/80-66 . . . .	2	IX-1985
Reverser: Description - Servicing - See Mods. 466/566/666/766 . . . . .	3-4	VII-1984	Rotary valve wear check - See Mods. 466/566/666/766 . . . . .	5	VII-1984
<b>204 - POWER TRAIN - Bevel drive and differential</b>			Return to neutral check - See Mods. 466/566/666/766 . . . . .	5	VII-1984
Removal - Installation - Disassembly - Assembly of bevel drive and differen- tial . . . . .	1	X-1987	Seal check - See Mods. 466/566/666/ 766 . . . . .	5	VII-1984
Bevel pinion shaft removal/installation	2	X-1987	Relief valve setting - See Mods. 466/ 566/666/766 . . . . .	5	VII-1984
Bevel drive adjustment . . . . .	2	X-1987	Cylinder safety valve setting - See Mods. 466/566/666/766 . . . . .	6	VII-1984
Differential pinion/side gear backlash adjustment . . . . .	2	X-1987	Power steering control valve servicing - See Mods. 466/566/666/766 . . . . .	7	VII-1984
Bevel drive/differential longitudinal and cross sections . . . . .	1	X-1987	Trouble shooting chart - See Mods. 466/566/666/766 . . . . .	8-9	VII-1984
Differential lock installation and adjust- ment . . . . .	2	X-1987	Operation schematics and sections - See Mods. 466/566/666/766 . . . . .	10-11	VII-1984
<b>205 - POWER TRAIN - Brakes</b>			<b>40 - FRONT WHEEL DRIVE - Specifications and Data</b>		
Brake unit removal and installation . .	1	X-1987	Live front axle . . . . .	1-2	X-1987
Brake pedal adjustments . . . . .	1	X-1987	Axle drive - Drive shafts . . . . .	2	X-1987
Parking brake hand lever adjustments	1-2	X-1987	Torque Data . . . . .	2	X-1987
<b>206 - POWER TRAIN - Side Final drives</b>					
Removal . . . . .	1	X-1987			
Assembly . . . . .	1	X-1987			
Disassembly . . . . .	2	X-1987			

	Page	Date		Page	Date
<b>401 - FRONT WHEEL DRIVE: Live front axle</b>			<b>502 - HYDRAULIC LIFT UNIT: Lift pump</b>		
Removal - Side final drives, wheel hubs and steering articulation servicings - See Mods. 466DT/566DT/666T/766DT	1-2	VII-1984	Servicing - See Mods. 466/566/666/766	1-2	
Steering knuckle kingpin bearing adjustments - See Mods. 466DT/566DT	2-3	VII-1984	Output test - See Mods. 466/566/666/766	2	
Wheel hub bearings adjustment - See Mods. 466DT/566DT	4-5	X-1987			
Bevel drive/Differential unit servicing - See Mods. 466DT/566DT	7-8	IX-1985	<b>503 - HYDRAULIC LIFT UNIT: Implement attachment</b>		
Bevel drive gear adjustments - See Mods. 466DT/566DT	8 thru 13	VII-1984	Implement attachment - RH lifting rod - See Mod. 70-66	1	IX-1985
NO-SPIN differential unit - See Mod. 45-66 DT	3	X-1987	Draft control device - See Mods. 55-66/60-66/70-66/80-66	2	IX-1985
<b>402 - FRONT WHEEL DRIVE: Drive shafts - Axle drive</b>			<b>504 - HYDRAULIC LIFT UNIT - Remote control valves</b>		
Drive shaft removal and installation - Axle drive removal - See Mods. 466/566/666/766	1	IX-1985	Description and operation - See Mods. 466/566/666/766	1	VII-1984
Axle drive installation - See Mods. 466/566/666/766	2	VII-1984	Hydraulic system schematics - See Mods. 466/566/666/766	1-2-3	VII-1984
Front wheel drive sections	1-2	X-1987	Disassembly - See Mods. 466/566/666/766	4-5	VII-1984
<b>50 - HYDRAULIC LIFT UNIT: Specifications and Data</b>			Pressure relief valve setting - See Mods. 466/566/666/766	5	VII-1984
Lift	1	X-1987	Valve spool return test - See Mods. 466/566/666/766	6	VII-1984
Hydraulic pump - See Mods. 55-66/60-66/70-66/80-66	2	IX-1985	Remote control valve leakage test - See Mods. 466/566/666/766	7	IX-1985
Implement attachment	2	X-1987	<b>60 - ELECTRICAL SYSTEM - Specifications and Data</b>		
Remote control valves	2	X-1987	Battery charge system - See Mods. 466/566/666/766	1	VII-1984
Lift trouble shooting chart - See Mods. 466/566/666/766	6	VII-1984	Starter motor - See Mods. 466/566/666/766	2 thru 11	VII-1984
Torque Data - See Mods. 466/566/666/766	7	VII-1984	Fuses	1	X-1987
			Lighting - Signals - Accessories - See Mods. 466/566/666/766	13	VII-1984
<b>501 - HYDRAULIC LIFT UNIT - Lift</b>			Switches - See Mods. 55-66/60-66/70-66/80-66	3	IX-1985
Description - See Mods. 466/566/666/766	1	VII-1984	Instrument panel	1	X-1987
Disassembly - Inspection - Assembly	1	X-1987	Fusebox - See Mods. 466/566/666/766	15	VII-1984
Position control adjustment	2-3	X-1987	Wiring diagram	2	X-1987
On-bench max lift arm travel adjustment	3	X-1987	<b>90 - SERVICE TOOLS - See Mods. 55-66/60-66/70-66/80-66</b>		
Draft control adjustments	3 thru 6	X-1987		1-2-3-4	IX-1985
Position control rod linkage adjustments	6-7	X-1987			
Draft control rod linkage adjustment	7	X-1987			
LIFT-O-MATIC adjustment	8	X-1987			
On-Tractor max lift arm travel adjustment	8	X-1987			
Valve checks - See Mods. 55-66/60-66/70-66/80-66	4	IX-1985			
Lift hydraulic system schematics - See Mods. 466/566/666/766	14-15	VII-1984			
Operation - Motion schematics	6	IX-1985			

**A**

*page 6*

**GENERAL:**

**IDENTIFICATION DATA**

Marketing Code

- Two-wheel drive .....
- Four-wheel drive .....

Engineering Code:

- 12-speed, two-wheel drive .....
- 12-speed, two-wheel drive with mechanical reverser .....
- 20-speed, two-wheel drive .....
- 12-speed, four-wheel drive .....
- 12-speed, four-wheel drive with mechanical reverser .....
- 20-speed, four-wheel drive .....

Engine type (common to all versions) .....

	<b>55-66 LP</b> <b>55-66 DTLP</b>	<b>60-66 LP</b> <b>60-66 DTLP</b>	<b>70-66 LP</b> <b>70-66 DTLP</b>
	669.103.000	670.103.000	671.103.000
	669.103.000 var. 720.110	670.103.000 var. 720.110	671.103.000 var. 720.110
	669.103.000 var. 720.111	670.103.000 var. 720.111	671.103.000 var. 720.111
	669.115.000	670.115.000	671.115.000
	669.115.000 var. 720.110	670.115.000 var. 720.110	671.115.000 var. 720.110
	669.115.000 var. 720.111	670.115.000 var. 720.111	671.115.000 var. 720.111
	FIAT 8035.06.308 (C.A.V. pump) 8035.06.208 (BOSCH pump)	FIAT 8035.05.308 (C.A.V. pump) 8035.05.208 (BOSCH pump)	FIAT 8045.06.308 (C.A.V. pump) 8035.06.208 (BOSCH pump)
	kg      lb	kg      lb	kg      lb
	2200    4840	2200    4840	2400    4840
	2400    5280	2400    5280	2600    5720
	Refer to applicable data on pages 3 and 4, Sect. 00, for Mods. 55-66/60-66/70-66		

**WEIGHTS**

Operating weight (including lift, implement attachment, tow hook and ROPS)

- Two-wheel drive .....
- Four-wheel drive .....

**ENGINE** .....



**POWER TRAIN**

**Clutch** . . . . . see Mods. 55-66/60-66/70-66

**Transmission** . . . . . see Mods. 55-66/60-66/70-66  
and 80-66

**Central bevel gear** on differential

**Differential** of the two-pinion type, with pedal-controlled differential lock.

**Side final drives** of the epicyclic, three planetary gear design.

**BRAKES****Service**

Axle shaft-mounted, oil bath disc type.  
Mechanically controlled through two separate pedals  
(latchable for one foot operation).

**Parking/Emergency**

Acting on service brakes, mechanically operated by hand lever.

**STEERING**

Hydrostatic power steering with independent circuit.  
Permanent lubricated joint steering control linkage.

**FRONT AXLE**

(Mods. 55-66LP/60-66LP/70-66LP)

Center swing, telescoping, inverted-U beam axle.  
Sliding axle end track adjustments:  
Settings . . . . . 6

**LIVE FRONT AXLE**

(Mods. 55-66DTLP/60-66DTLP/70-66DTLP)

Full-floating, center-swing, articulations and unjointed drive shaft on tractor centerline.

Two-pinion and planetary epicyclic side final drive gears in wheel hubs.

Optional: NO-SPIN differential.

Track width adjustments by relative re-positioning of Disc/Rim/Hub:

Settings . . . . . 8

**REAR WHEELS**

Track width adjustments by relative re-positioning of Disc/Rim/Hub:

Settings . . . . . 7

**POWER-TAKE-OFF**

**Fully independent** . . . . . see Mods.  
55-66/60-66/70-66/80-66

**Ground Speed**

Drive shaft and rotation same as fully independent PTO.  
Shaft drive ratios (synchronized w/transmission):

— 540 RPM . . . . . 7.7 revs per wheel turn  
— 1000 RPM . . . . . 13.1 revs per wheel turn

**HYDRAULIC LIFT** . . . . . see Mods.  
55-66/60-66/70-66/80-66

**Remote Control Valves**

One or two valves may be used:

— Single- and double-acting, convertible.  
— Double-acting, float position.

**TOWING ATTACHMENTS**

Drilled cross member.

Rear swinging drawbar.

Rigid rear tow hook, height adjustable.

**BALLASTS****Front Axle**

Two or three, cast-iron, 45 kg (90 lb) plates for a total of 90 or 135 kg (198 or 297 lb).

**Rear Wheels**

Four cast-iron, 50 kg (110 lb) rings mounted on wheel discs for a total of 200 kg (440 lb).

**BODY**

One-piece, forward-tilting hood.

Conventional Operator's compartment.

Partly wrap-around, load-bearing fenders carrying the ROPS mounts.



Diesel fuel tank location: behind Operator's seat.  
Operator's seat: padded, with parallelogram plus hydraulic damper suspension; adjustable ride and position.

**ELECTRICAL SYSTEM**

Voltage . . . . . 12 V  
Alternator with integral electronic voltage regulator.  
Makes: LUCAS 18 ACR-14V-40A or MARELLI AA 108-14V-33A-1 or ISKRA AAG 110A-14V-33A.

Starter Motor Makes:

- Mods. 55-66 LP and 60-66 LP MARELLI . MT 71 AA  
BOSCH . . . JF 12 V  
LUCAS . . . 2M 113
- Mods. 70-66 LP MARELLI . MT 68 AB  
BOSCH . . . JF 12 V

Battery located ahead of radiator, ratings: 88/92 Ah and 110/120 Ah (standard batteries) or 100 Ah or 132 Ah (sealed, maintenance free batteries).

**TIRE SIZES**

	55-66 LP	60-66 LP and 70-66 LP	55-66 DTLP	60-66 DTLP and 70-66 DTLP
Front	6.00-16 6.50-16	6.50-16	7.50-20 <sup>(1)</sup> 9.5/9-20 <sup>(2)</sup>	9.5/9-20 <sup>(1)</sup> 11.2/10-20 <sup>(2)</sup>
Rear	13.6/12-28 14.9/13-28	14.9/13-28 16.9/14-28	13.6/12-28 <sup>(1)</sup> 14.9/13-28 <sup>(2)</sup>	14.9/13-28 <sup>(1)</sup> 16.9/14-28 <sup>(2)</sup>

<sup>(1)</sup> <sup>(2)</sup> Tire matching references.

**MAIN DIMENSIONS**

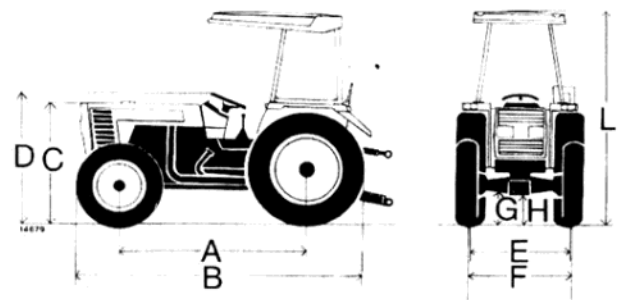
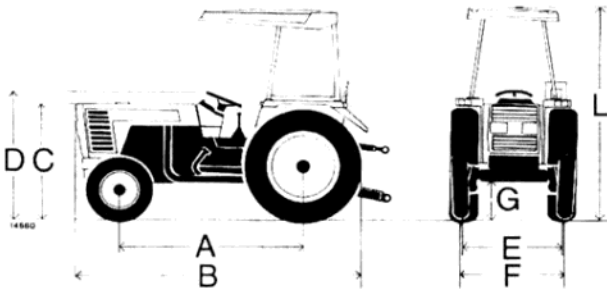

**Standard tires (mm)**

Models	A mm	B mm	C mm	D mm	E mm	F mm	G mm	L mm
55-66 LP	2056	3065	1270	1426	1410 + 1910	1494 + 2005	460	2246
60-66 LP	2056	3090	1270	1426	1410 + 1910	1494 + 2005	460	2264
70-66 LP	2171	3205	1270	1426	1410 + 1910	1494 + 2005	460	2264

**Standard tires (mm)**

Models	A mm	B mm	C mm	D mm	E mm	F mm	G mm	H mm	L
55-66 DTLP	1970	3067	1245	1381	1385 + 1820	1494 + 2005	362	300	2246
60-66 DTLP	1970	3108	1260	1394	1400 + 1805	1494 + 2005	334	314	2264
70-66 DTLP	2085	3223	1260	1394	1400 + 1805	1494 + 2005	334	314	2264

**Standard tires (inches)**

Models	A	B	C	D	E	F	G	L
55-66 LP	81	120.6	50	56.2	55.5 to 75.2	58.8 to 80	18	88.4
60-66 LP	81	121.6	50	56.2	55.5 to 75.2	58.8 to 80	18	89
70-66 LP	85	126.2	50	56.2	55.5 to 75.2	58.8 to 80	18	89

**Standard tires (inches)**

Models	A	B	C	D	E	F	G	H	L
55-66 DTLP	77	120.7	49	54.5	54.5 to 71.6	58.8 to 80	14.2	11.8	88.4
60-66 DTLP	77	122.4	49.6	54.9	55.1 to 71	58.8 to 80	13.1	12.4	89
70-66 DTLP	82	126.9	49.6	54.9	55.1 to 71	58.8 to 80	13.1	12.4	89

POWER TRAIN SCHEMATICS

Mods. 55-66LP/55-66DTLP/60-66LP/60-66DTLP  
70-66LP/70-66DTLP - 12-speed Versions

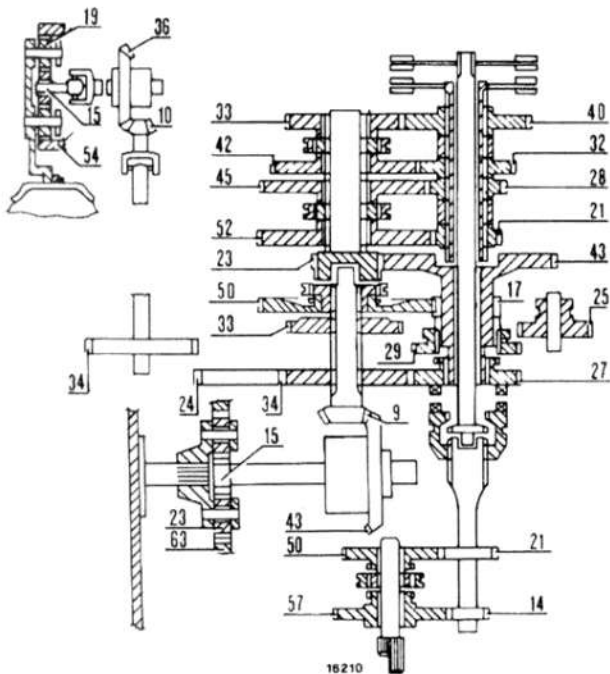

Mods. 55-66LP/55-66DTLP/60-66LP/60-66DTLP  
70-66LP/70-66DTLP - Splitter Versions

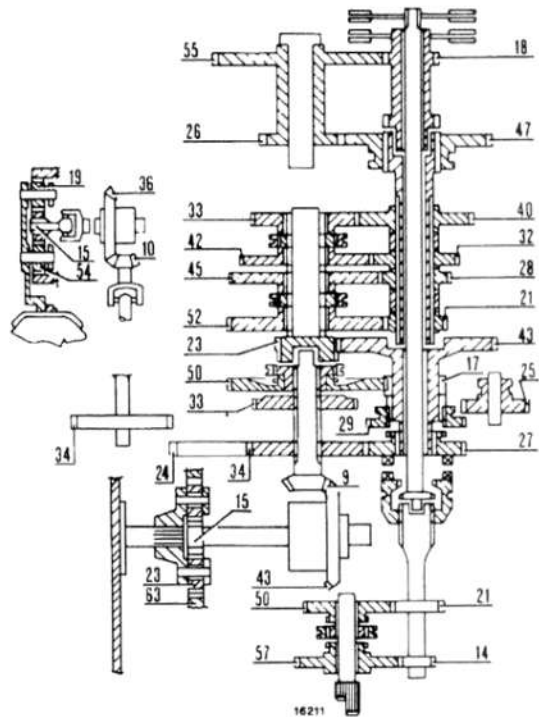

Travel speeds with engine at max power speed rating and rear tires as tabulated below.

Marcia	55-66LP		55-66LP 60-66LP 70-66LP		60-66LP 70-66LP	
	13.6/12-28		14.9/13-28		16.9/24-28	
	kph	mph	kph	mph	kph	mph
1st Low	1.7	1	1.8	1.1	1.9	1.2
2nd *	2.6	1.6	2.7	1.7	2.9	1.8
3rd *	3.2	2	3.4	2.1	3.5	2.2
4th *	5.1	3	5.3	3.3	5.6	3.5
1st Normal	4.0	2.4	4.2	2.5	4.3	2.6
2nd *	6.2	3.8	6.4	3.9	6.7	4.0
3rd *	7.5	4.6	7.9	4.9	8.2	5.0
4th *	12.0	7.4	12.5	7.7	13.1	8.2
1st High	9.4	5.8	9.8	6.0	10.3	6.4
2nd *	14.5	9.0	15.1	9.4	15.8	9.8
3rd *	17.8	11	18.5	11.5	19.4	12
4th *	28.3	17	29.4	18.2	30.8	19
1st Reverse	4.4	2.7	4.6	2.8	4.8	2.9
2nd *	6.8	4.2	7.1	4.4	7.4	4.6
3rd *	8.4	5.2	8.7	5.4	9.1	5.6
4th *	13.3	8.2	13.8	8.5	14.5	9.0

Travel speeds, with engine at max power speed rating and rear tires as tabulated below.

Marcia	55-66LP				60-66LP, 70-66LP			
	13.6/12-38		14.9/13-28		14.9/13-28		16.9/14-28	
	kph	mph	kph	mph	kph	mph	kph	mph
1st Creeper low	0.3	0.18	0.3	0.18	0.3	0.18	0.3	0.18
2nd *	0.5	0.31	0.5	0.31	0.5	0.31	0.5	0.31
3rd *	0.6	0.37	0.6	0.37	0.6	0.37	0.6	0.37
4th *	0.9	0.56	0.9	0.56	1.0	0.62	1.0	0.62
1st Creeper Normal	0.7	0.43	0.7	0.43	0.7	0.43	0.8	0.50
2nd *	1.1	0.68	1.2	0.74	1.2	0.74	1.2	0.74
3rd *	1.4	0.87	1.4	0.87	1.4	0.87	1.5	0.93
4th *	2.2	1.36	2.3	1.43	2.3	1.43	2.4	1.50
1st Low	1.7	1.00	1.8	1.12	1.8	1.12	1.9	1.18
2nd *	2.6	1.61	2.7	1.67	2.7	1.67	2.9	1.80
3rd *	3.2	1.98	3.4	2.10	3.4	2.10	3.5	2.20
4th *	5.1	3.16	5.3	3.30	5.3	3.30	5.6	3.47
1st Normal	4.0	2.4	4.2	2.6	4.2	2.5	4.3	2.6
2nd *	6.2	3.8	6.4	3.9	6.4	3.9	6.7	4.0
3rd *	7.5	4.6	7.9	4.9	7.9	4.9	8.2	5.0
4th *	12.0	7.4	12.5	7.7	12.5	7.7	13.1	8.2
1st High	9.4	5.8	9.8	6.0	9.8	6.0	10.3	6.4
2nd *	14.5	9.0	15.1	9.4	15.1	9.4	15.8	9.8
3rd *	17.8	11.0	18.5	11.5	18.5	11.5	19.4	12.0
4th *	28.3	17.5	29.4	18.2	29.4	18.2	30.8	19.0
1st Low Reverse	0.8	0.49	0.8	0.49	0.8	0.49	0.9	0.56
2nd *	1.2	0.75	1.3	0.80	1.3	0.80	1.3	0.80
3rd *	1.5	0.93	1.6	0.99	1.6	0.99	1.6	0.99
4th *	2.4	1.48	2.5	1.55	2.5	1.55	2.6	1.61
1st High Reverse	4.4	2.73	4.6	2.85	4.6	2.85	4.8	2.97
2nd *	6.8	4.21	7.1	4.40	7.1	4.40	7.4	4.58
3rd *	8.4	5.20	8.7	5.40	8.7	5.40	9.1	5.64
4th *	13.3	8.2	13.8	8.5	13.8	8.5	14.5	9.0

**POWER TRAIN SCHEMATICS**

**Mods. 55-66LP/55-66DTLP/60-66LP/60-66DTLP/70-66LP/70-66DTLP - Mechanical reverser Versions**

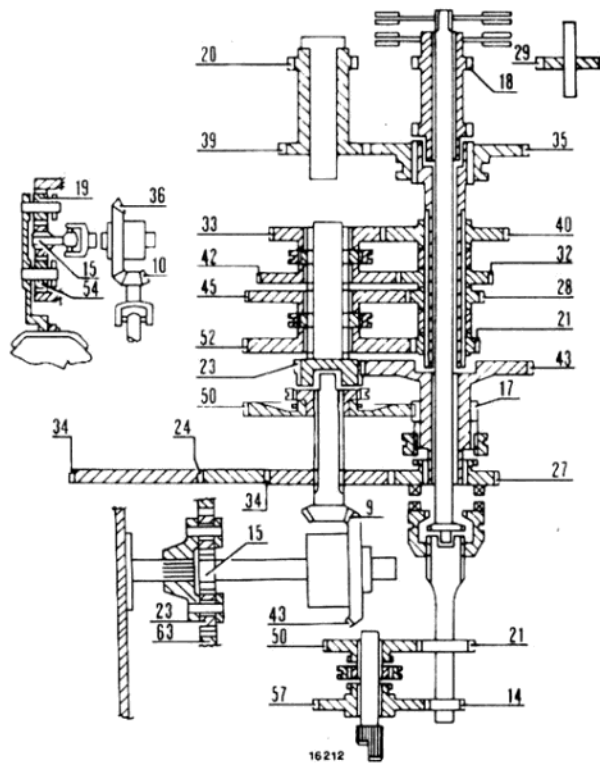

Travel speeds with engine at max. power speed rating and tires as tabulated below						
Reverse	55-66LP		55-66LP 60-66LP 70-66LP		60-66LP 70-66LP	
	13.6/12-38		14.9/13-28		16.9/14-28	
	kph	mgh	kph	mgh	kph	mgh
1st Low	1.7	1	1.8	1.1	1.9	1.2
2nd »	2.6	1.6	2.8	1.74	2.9	1.8
3rd »	3.2	2	3.4	2.1	3.5	2.2
4th »	5.2	3.2	5.4	3.4	5.6	3.5
1st Normal	4.0	2.4	4.2	2.5	4.4	2.5
2nd »	6.2	3.8	6.4	3.9	6.7	4.0
3rd »	7.6	4.7	7.9	4.9	8.2	5.0
4th »	12.0	7.4	12.5	7.7	13.1	8.2
1st High	9.4	5.8	9.8	6.0	10.3	6.4
2nd »	14.5	9.0	15.1	9.4	15.9	9.8
3rd »	17.8	11	18.5	11.5	19.4	12
4th »	28.3	17	29.5	18.3	30.9	10.1

Travel speeds with engine at max. power speed rating and tires as tabulated below						
Forward	55-66LP		55-66LP 60-66LP 70-66LP		60-66LP 70-66LP	
	13.6/12-38		14.9/13-28		16.9/14-28	
	kph	mgh	kph	mgh	kph	mgh
1st Low	1.7	1	1.8	1.1	1.9	1.2
2nd »	2.6	1.6	2.7	1.67	2.9	1.8
3rd »	3.2	2	3.4	2.1	3.5	2.2
4th »	5.1	3.0	5.3	3.3	5.6	3.5
1st Normal	4.0	2.4	4.2	2.5	4.3	2.6
2nd »	6.2	3.8	6.4	3.9	6.7	4.0
3rd »	7.5	4.6	7.9	4.9	8.2	5.0
4th »	12.0	7.4	12.5	7.7	13.1	8.2
1st High	9.4	5.8	9.8	6.0	10.3	6.4
2nd »	14.5	9.0	15.1	9.4	15.8	9.8
3rd »	17.8	11	18.5	11.5	19.4	12
4th »	28.3	17	29.4	18.2	30.8	19

## FLUID CAPACITIES

DESCRIPTION	RECOMMENDED FIAT PRODUCT	CAPACITIES								INTERNATIONAL DESIGNATION
		QUANTITY				QUANTITY				
		55-66LP/60-66LP		70-66LP		55-66LP/60-66LP		70-66LP		
dm <sup>3</sup> (litri)	Imp. Gals	kg	dm <sup>3</sup> (litri)	Imp. Gals	kg	dm <sup>3</sup> (litri)	Imp. Gals	kg		
Engine sump and filters . . . . .	<b>Olio fiat AMBRA SUPER</b>	7.3	1 2/3	6.6	11.7	2 3/4	10.5	10.5	Diesel engine oil meeting MIL-L-2104D and API-CD Service specs	
Sump only . . . . .		6.7	1 1/2	6	10.5	2 1/3	9.5	9.5		
Hydrostatic steering system . . . . .	<b>Olio fiat TUTELA MULTI F</b>		Imp. Pts			Imp. Pts			Transmission, drives, oil bath brakes and hydraulic lift oils-meeting Massey Ferguson MF 1135 and Ford M2 C 86 A specs.	
Front axle		1.7	3	1.5	1.7	3	1.5			
— Axle housing . . . . .		4.3	9 1/2	3.9	4.3	9 1/2	3.9			
— Side final drives (each) . . . . .		1.1	2 1/5	1.0	1.1	2 1/5	1.0			
Rear drive housing (transmission, bevel gear and brakes) plus lift:		Imp. Gals			Imp. Gals					
— Two-wheel drive . . . . .	45	9 4/5	40.5	45	9 4/5	40.5				
— Four-wheel drive . . . . .	45.5	10	41	45.5	10	41				
Front wheel hubs . . . . .	<b>Grassofiat TUTELA G9</b>	—	—	—	—	—	—	—	Lithium-calcium base grease with NLGI No. 2 consistency	
Grease fittings . . . . .		—	—	—	—	—	—	—		
Cooling system . . . . .	<b>FIAT Water and PARAFU 11</b>	10.5	2 1/3	—	13.5	3	—	—		
Fuel tank . . . . .	Decanted and filtered Diesel fuel	65	14 1/3	—	65	14 1/3	—	—		

**CLUTCH - LUK 11"/11"**

Type .....	Twin, single plate, dry
Control: — Master (transmission) clutch .....	Mechanical by pedal
— PTO clutch .....	Manual, by lever
Release mechanism .....	Single, dished spring
Plate facing material: — Master clutch .....	Organic compound
— PTO clutch .....	Organic compound
Driven plate thickness: — Master clutch .....	8.9 to 9.5 mm (0.3504 to 0.3740 in)
— PTO clutch .....	8.3 to 8.9 mm (0.3268 to 0.3504 in)
Wear limiti .....	See page 7, Sect. 201, for Mods. 466/566/666/766
Master (transmission) clutch control sleeve to seat clearance .....	0.050 to 0.151 mm (0.0020 to 0.0059 in)
PTO clutch control sleeve to seat clearance .....	0.060 to 0.180 mm (0.0024 to 0.0070 in)
Release lever alignment .....	See pages 10 and 11, Sect. 201 for Mods. 466/566/666/766
Clutch linkage adjustment .....	See pages 1 and 2, Sect. 201

**CLUTCH - VALEO 11"/11"**

Type .....	Twin, single plate, dry
Control: — Master (transmission) clutch .....	Mechanical, by pedal
— PTO clutch .....	Manual, by lever
Release mechanism .....	Single, dished spring
Plate facing material: — Master clutch .....	Organic compound
— PTO clutch .....	Organic compound
Driven plate thickness: — Master clutch .....	9.4 to 10 mm (0.3700 to 0.3939 in)
— PTO clutch .....	8.5 to 8.9 mm (0.3346 to 0.3504 in)
Wear limiti .....	See page 3, Sect. 201, for Mods. 55-66/60-66/70-66/80-66
Transmission clutch control sleeve to seat clearance .....	0.05 to 0.151 mm (0.020 to 0.0059 in)
PTO clutch control sleeve to seat clearance .....	0.060 to 0.180 mm (0.0024 to 0.0070 in)
Release lever alignment .....	See pages 4 and 6, Sect. 201, for Mods. 55-66/60-66/70-66/80-66
Clutch linkage adjustment .....	See pages 1 and 2, Sect. 201

## POWER TRAIN: Specifications and Data

### CLUTCH - O.M.G. 11"/11"

Type .....	Twin, single-plate, dry
Control: — Master clutch .....	Mechanical, by pedal
— PTO clutch .....	Manual, by lever
— Release mechanism .....	Single, dished spring
Plate facing material: — Master clutch .....	Organic compound
— PTO clutch .....	Organic compound
Plate thickness: — Master clutch .....	8.8 to 9.4 mm (0.3464 to 0.3700 in)
— PTO clutch .....	8.7 to 9.0 mm (0.3425 to 0.3543 in)
Wear limits .....	See page 7, Sect. 201 for Mods. 466/566/666/766
Master (transmission) clutch control sleeve to seat clearance .....	0.050 to 0.151 mm (0.0020 to 0.0059 in)
PTO clutch control sleeve to seat clearance .....	0.060 to 0.180 mm (0.0024 to 0.0070 in)
Release lever alignment .....	See pages 10 and 11, Sect. 201 for Mods. 466/566/666/766
Clutch linkage adjustment .....	See pages 1 and 2, Sect. 201

### SIDE FINAL DRIVES

Type .....	Epicyclic, 3-planet, straight spur gears
Reduction ratio .....	15 to (15+63) = 1 to 5.2
Planet carrier adjustment shim thickness range .....	From 3.5 to 4.8 mm by 0.1 mm increments From 0.1378 to 0.1890 in by 0.0040 in increments

### POWER TAKE OFF

Data shown on page 3, Sect. 20, for Mods. 466/566/666/766 are applicable except

Ground speed PTO rotation: — At 540 Std. RPM .....	7.7 revs per wheel turn
— At 100 Std. RPM .....	13.1 revs per wheel turn

### TORQUE DATA

Data shown on pages 9 and 10, Sect. 20, for Mods. 466/566/666/766 are applicable except:

Item	Thread size	Torque		
		Nm	kgm	lb ft
<b>Side Final Drives - Sect. 206</b> Reduction housing stud nuts (C <sub>1</sub> , page 1) .....	M12x1.25	98	10	72
Driving wheel shaft lock screw (C <sub>2</sub> ) .....	M18x1.5	250	25.5	184



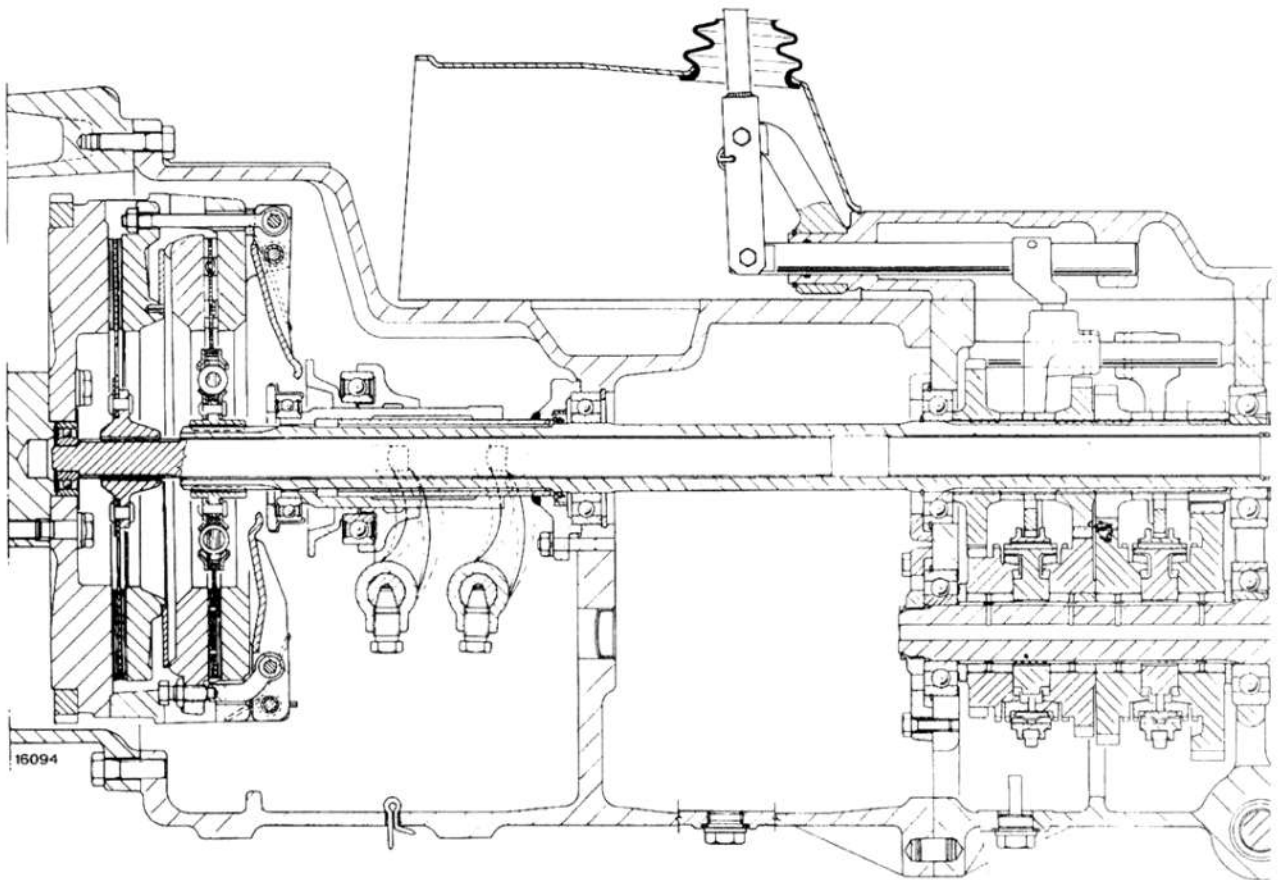

Power train longitudinal section

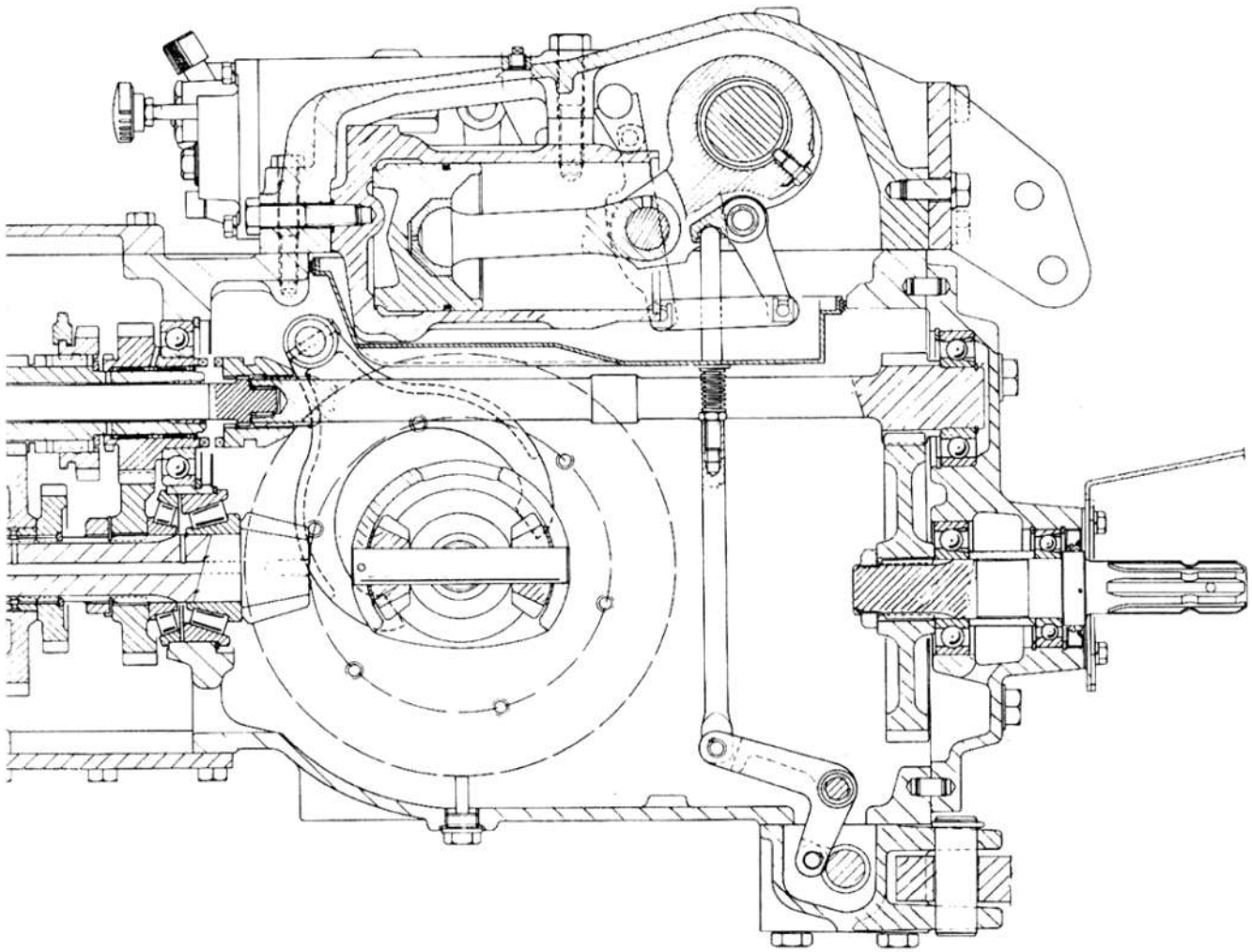

# POWER TRAIN: Specifications and Data

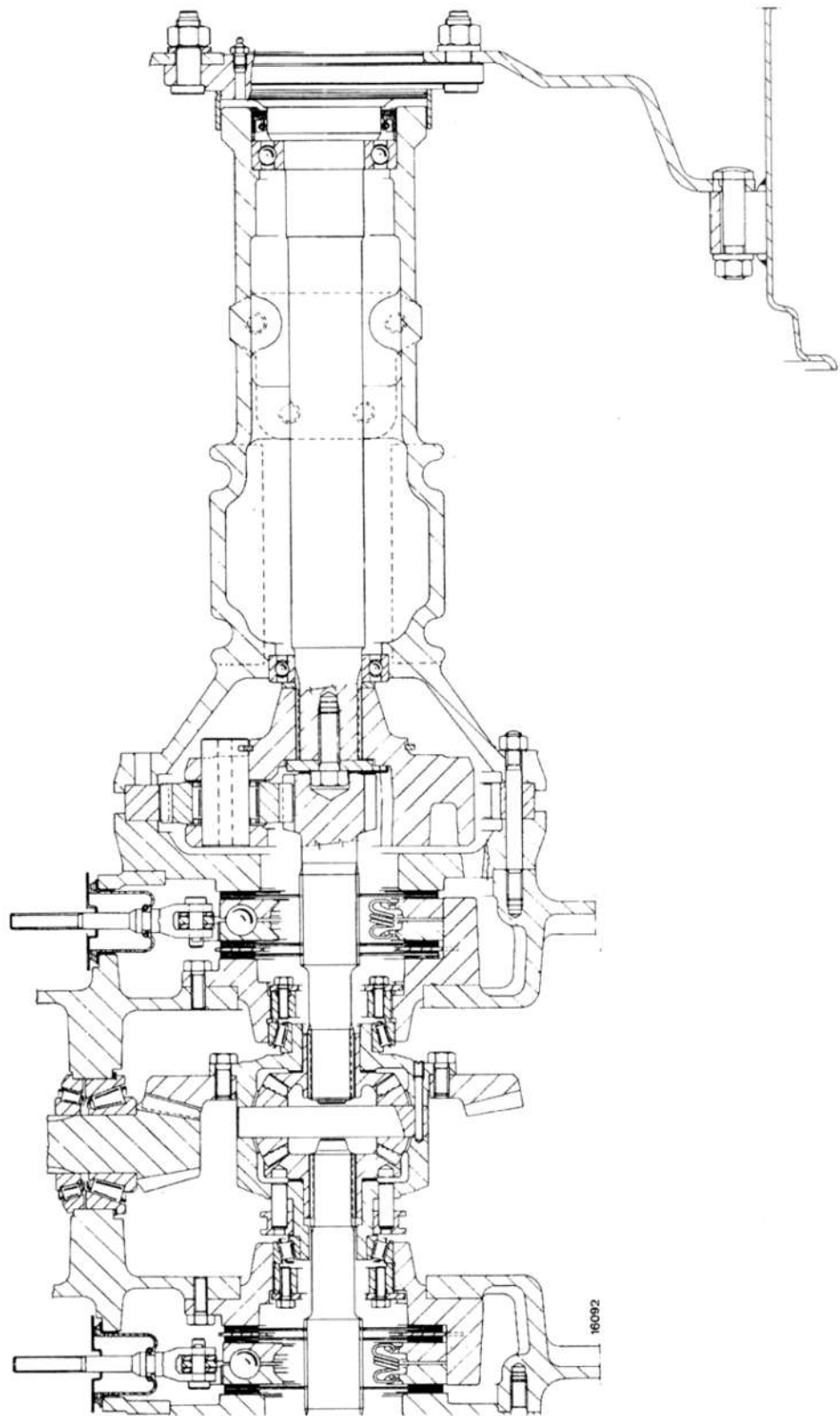

Power train cross section

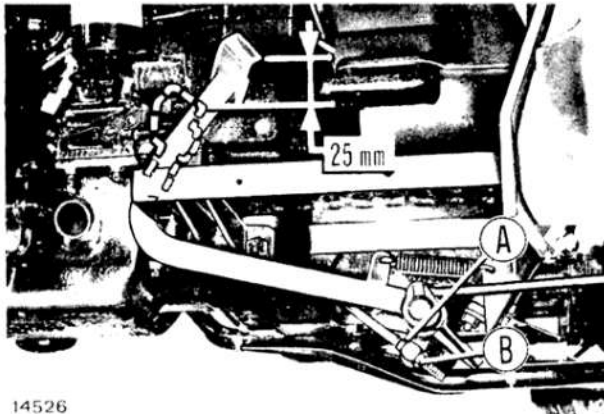

**Master clutch pedal free travel adjustment.**

A. Nut - B. Nut.

**VALEO 11"/11" CLUTCH SERVICING**

Refer to the text and illustrations provided on pages 1 thru 6, Sect. 201, Mods. 55-66/60-66/70-66/80-66.

**LUK 11"/11" CLUTCH SERVICING**

Refer to the text and illustrations provided on pages 6 thru 9, Sect. 201, Mods. 466/566/666/766.

The LUK 11"/11" clutch longitudinal section is instead shown on page 5, Sect. 201, Mods. 55-66/60-66/70-66/80-66.

**O.M.G. 11"/11" CLUTCH SERVICING**

Refer to the text and illustrations on pages 6 thru 9, Sect. 201, Mods. 466, 566, 666, 766.

**MASTER CLUTCH CONTROL LINKAGE ADJUSTMENT**

Check that pedal free travel before releasing clutch is approximately 25 mm (1 in).

When this travel wears down to 15 mm (.60 in) re-adjust as follows:

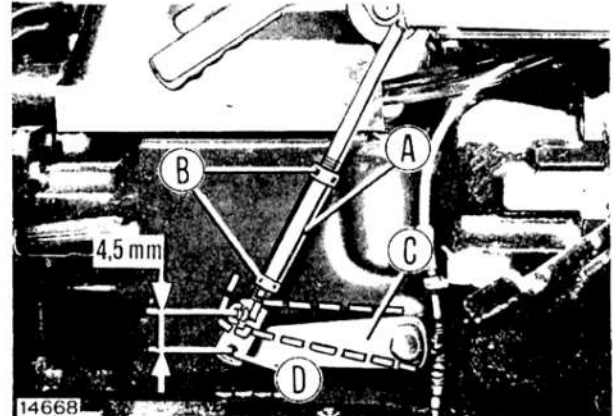

**PTO clutch hand lever free travel adjustment.**

A. Sleeve - B. Jam nut - C. Outer relay lever - D. Pin.

— Loosen nut (B) turn in nut (A) until the required pedal free travel of 25 mm (1 in) is restored.

— Re-lock jam nut (B).

— Check once more that pedal free travel is 25 mm as specified.

**PTO CLUTCH CONTROL ADJUSTMENT**

Set lever (C) to rest position (fully down) and check that free travel - in line with pin (D) - is approximately 4.5 mm (.18 in) before releasing the clutch.

When free travel is down to 2.5 mm (.10 in) re-adjust as follows:

— Loosen jam nuts (B) and turn sleeve (A) clockwise about 3/4 turn (each turn causes pin D to shift 3 mm - .12 in).

— Re-lock jam nuts (B).

— Check once more that lever free travel is 4.5 mm as specified.

---

**201**

---

*page 2*

**POWER TRAIN:  
Clutch**

---

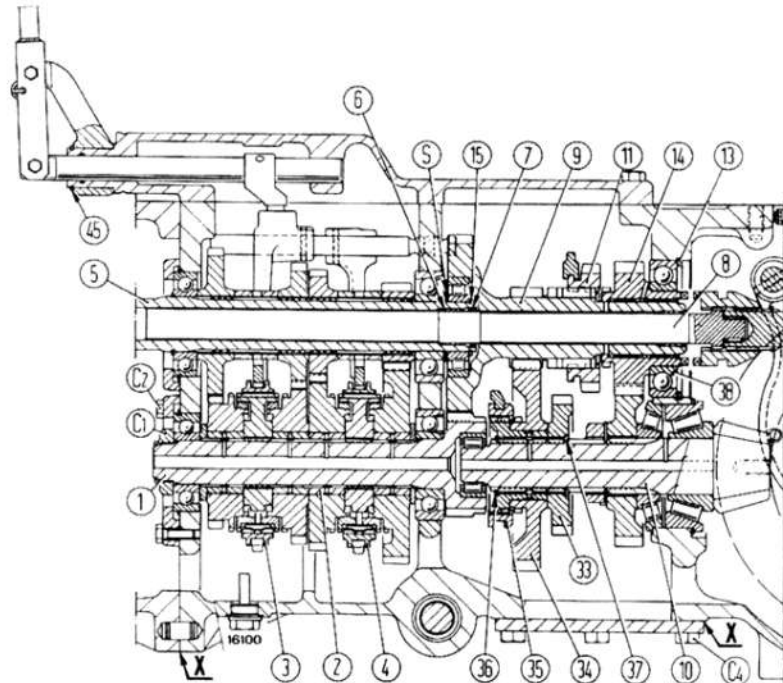

**Longitudinal and cross sections through transmission and splitter.**

C<sub>1</sub>. Driven gear drive shaft lock nut - C<sub>2</sub>. Bearing cover retaining screws - C<sub>3</sub>. Top cover retaining screws - C<sub>4</sub>. Bottom cover retaining screws - S. Drive shaft bearing shim - 1. Transmission driven gear support bushings - 2. Transmission driven gear support bushings - 3. 3rd/4th sliding sleeve - 4. 1st/2nd sliding sleeve - 5. Transmission drive shaft - 6. PTO shaft support bush - 8. PTO shaft - 9. Direct drive and low range drive shaft - 10. Bevel drive pinion shaft - 11. Reverse and normal range sliding gear - 13. - 15. - 36. - 45. Retaining rings - 14. Normal range drive gear - 16. Transmission shift lever - 17. Splitter shift lever - 18. 1st/2nd speed striker rod - 19. 3rd/4th striker rod - 20. Low/High range striker rod - 21. Normal/Reverse range striker rod - 22. Transmission shift control horizontal relay bar - 23. Splitter shift control horizontal relay bar - 33. Reverse gear - 34. Low range driven gear - 35. Low range/direct drive sliding sleeve - 37. Rings - 38. Bearings - 39. Transmission shift plunger - 40. Splitter shift plunger - 41. Transmission shift lever fulcrum support - 42. Splitter shift lever fulcrum support - 43. Transmission housing cover - 44. Spring.

**NOTE** - Upon reassembly, apply jointing compound to mating surfaces **X** as instructed on page 6, Sect. A, for Mods. 466/566/666/766.

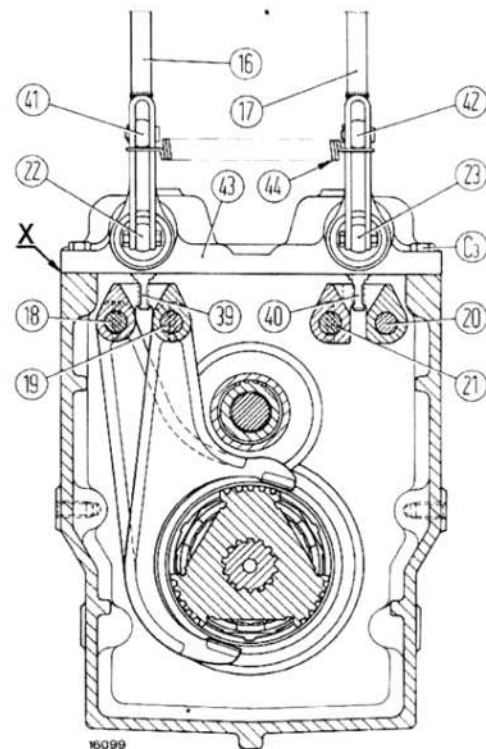

**TRANSMISSION REMOVAL-INSTALLATION**

Refer to the descriptions and illustrations shown on pages 1 thru 4, Sect. 202 for Mods. 55-66/60-66/70-66/80-66.

The Figures published on this page replace their counterparts given on page 1, Sect. 202, for Mods. 55-66/60-66/70-66/80-66.

**POWER TRAIN:  
Transmission**

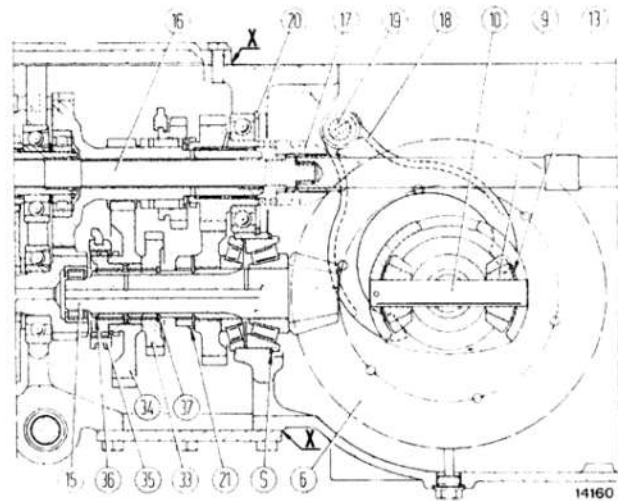
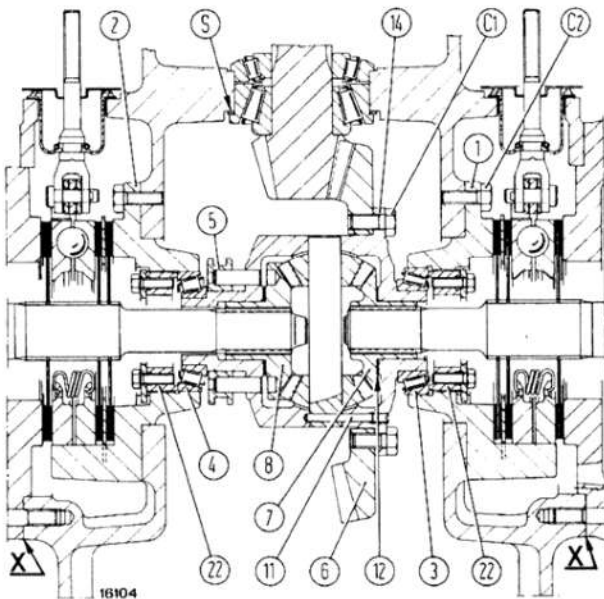

**Longitudinal and cross sections through bevel drive and differential.**

C<sub>1</sub>. Bevel ring gear retaining screws - C<sub>2</sub>. Differential support retaining screws - S. Bevel pinion positioning shims - 1 and 2. Differential supports - 3 and 4. Taper roller bearings - 5. Differential lock sleeve - 6. Bevel ring gear - 7 and 8. Side gears - 9. Differential pinion - 10. Journal - 11. Differential pinion journal retaining screw - 12 and 13. Shims - 14. Differential carrier - 15. Bevel pinion shaft - 16. P.T.O. shaft - 17. P.T.O. control sleeve - 18. Fork - 19. Differential lock shaft - 20. Retaining ring - 21. Lockwasher - 22. Differential bearing adjuster ring nut - 33. Reverse gear - 34. Creeper, driven gear - 35. Creeper and DD engagement sleeve - 36. Retaining ring - 37. Shims.

**Note** - On assembly, thoroughly clean and degrease mating surfaces **X** and apply one of the jointing compounds indicated on page 6, section A, for Mods. 466/566/666/766.

**BEVEL DRIVE - DIFFERENTIAL REMOVAL/  
INSTALLATION**

Proceed as follows:

**CAUTION**

Lift and handle all heavy parts using a suitable hoist. Ensure that units or parts are supported by suitable slings or hooks. Ensure that no one is in the vicinity of load to be lifted.

- Drain drive housing oil and fuel tank.
- Disconnect battery negative lead, power point wiring and lift lines.
- Remove ROPS frame, fenders and remote control valves, when fitted.
- Take down fuel tank.
- Remove Operator's seat, lift with control levers and transmission housing top cover with levers.
- Position a support stand under transmission housing, then remove wheels, side final drives, brake units, sensing bar support and PTO housing.

— Take off bearing supports and remove bevel drive/differential unit from top of rear drive housing.

Disassemble unit as follows:

- Remove screws (C<sub>1</sub>) and separate ring gear from differential carrier.
- Remove screw (11) and journal (10) retaining differential pinions and side gears.

On reassembly, proceed as follows:

- Coat differential pinion washers with **Fiat TUTELA G9 grease**
- Turn in and tighten screws (C<sub>1</sub>) to the specified torque.
- Adjust taper roller bearings as instructed in applicable Sections.
- Adjust differential lock as instructed in applicable Section.

**CAUTION**

Handle all parts carefully. **DO NOT** put hand and fingers between parts.  
Wear safety equipment such as goggles, gloves and shoes.

## POWER TRAIN: Bevel Drive and Differential

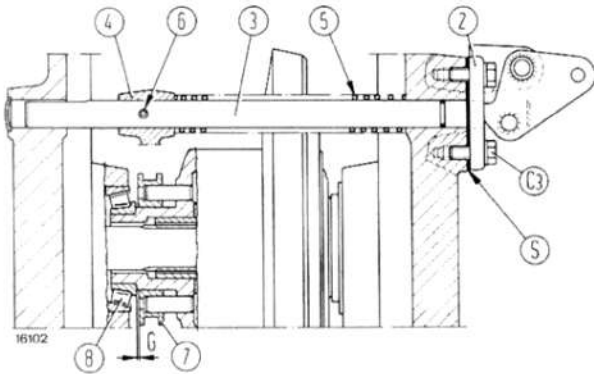

### Installing and adjusting differential lock.

C<sub>3</sub>. Differential lock lever support screws - G = 2 mm (0.08 in).  
Clearance between sleeve (7) and bearing (8) - S. Sleeve positioning shims - 2. Lever support - 3. Fork shaft - 4. Fork - 5. Spring - 6. Roll pin - 7. Differential lock sleeve - 8. Differential bearing.

### BEVEL PINION SHAFT REMOVAL/INSTALLATION

Proceed as instructed on pages 1 and 2, Sect. 204, for Mods. 55-66/60-66/70-66/80-66.

### BEVEL DRIVE ADJUSTMENT

**Bevel pinion position adjustment and shim thickness measurement.**

**Bevel pinion shaft taper roller bearing adjustment.**

Proceed as instructed on pages 2, 3 and 4 Sect. 204, for Mods. 55-66/60-66/70-66/80-66.

### Differential bearing adjustment and bevel drive gear backlash check.

Refer to text and illustrations on pages 7 and 8, Sect. 204, for Mods. 466/566/666/766.

### DIFFERENTIAL PINION AND SIDE GEAR BACKLASH ADJUSTMENT

Refer to text and illustrations on pages 8 and 9, Sect. 204, for Mods. 466/566/666/766.

### DIFFERENTIAL LOCK INSTALLATION AND ADJUSTMENT

Assemble differential lock using tool **293452** to compress return spring (5) and to insert roll pin (6) which secures fork (4) in its seat on shaft.

Install bevel ring gear-differential unit on supports. Using a feeler gauge, check that clearance (G) between sleeve (7) and R.H. differential bearing is 2 mm (0.08 in). Adjust clearance by changing shims (S) between support (2) and transmission housing.

### BRAKE UNIT REMOVAL AND INSTALLATION

**CAUTION**

Lift and handle all heavy components using a suitable hoist. Ensure that units or parts are supported by suitable slings or hooks. Ensure that no one is in the vicinity of the load to be lifted.

Disassemble brake unit as follows:

- Drain transmission housing oil.
- Position a support stand under drive housing and remove ROPS, wheels, fenders and footboards.
- Unscrew retaining stud nuts (C<sub>1</sub>, page 1, Sect. 206) and remove splitter housing.
- Remove cotter pin and pin (2) securing brake pedal to link (1).
- Back off link (1) from spring side and remove complete brake unit.
- Check actuator (4) and brake discs (5) for wear. Replace discs when sintered material is almost worn out.

On brake unit installation, use driver **293847** as shown to position boot (11) correctly on brake link (1).

Before installing side final drive housing on rear drive housing, thoroughly clean and degrease mating surfaces and apply a 2 mm (0.08 in) bead of jointing compound as shown in Figure on page 2.

Jointing compound types are indicated on page 6, Section A, for Mods. 466/566/666/766.

### BRAKE PEDAL ADJUSTMENT

Check that pedal free travel is the same for both pedals and does not exceed 80 mm (3.15 in).

To adjust, proceed as follows:

- Move brake hand lever down.
- Back off jam nuts (A, page 2) and turn sleeves (B) until free travel is 45 mm (1.77 in).

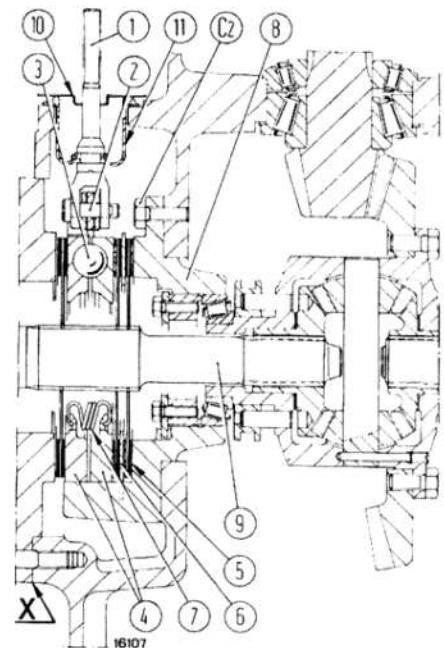

Sections through brake unit.

C<sub>2</sub>. Differential support screws - 1. Brake link - 2. Pin - 3. Ball - 4. Brake actuator - 5. Brake discs - 6. Back-up disc - 7. Actuator pull-off spring - 8. Differential support - 9. Axle shaft - 10. Boot cover plate - 11. Boot.

**NOTE** - On assembly, apply jointing compound to surface X as directed in notes and in diagram on page 2.

**Important** - New brake discs must be soaked for at least 2 hours or preferably for 5 to 6 hours, in TUTELA MULTI F oil before installation.

### PARKING BRAKE LEVER ADJUSTMENT

After adjusting the pedal (service) brakes, check parking (hand) lever adjustment as follows:

- Move lever to rest position.
- Back off jam nut (C, page 2).
- Turn sleeve (D) until it contacts bracket (E).
- Lock jam nut (C).
- Next, adjust hand lever travel.

## POWER TRAIN: Brakes

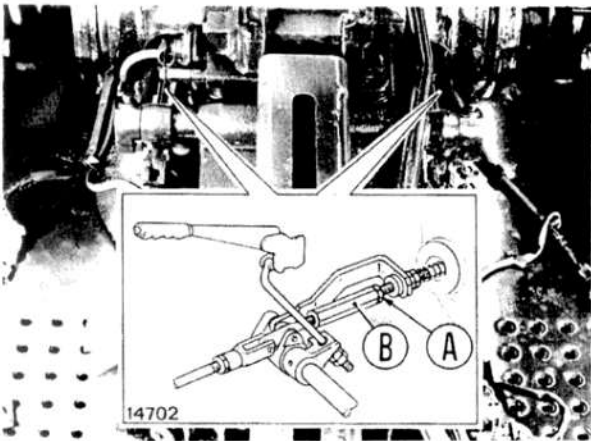

### Service brake pedal travel adjustment.

A. Jam nut - B. Adjuster sleeves.

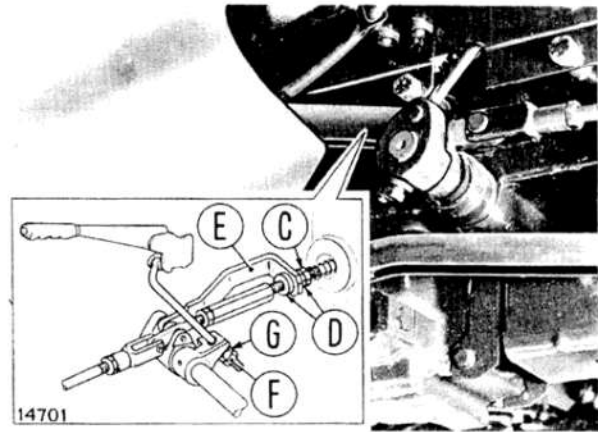

### Parking brake hand lever adjustment.

C. Jam nut - D. Adjuster sleeve - E. Reaction bracket - F. Jam nut - G. Nut.

by acting on RH link rod as follows:

- Release jam nut (F).
- Turn in or out, as required, nut (G) while checking at the same time that hand lever applies brake tight at 4th click on toothed sector.
- Re-lock jam nut (F).

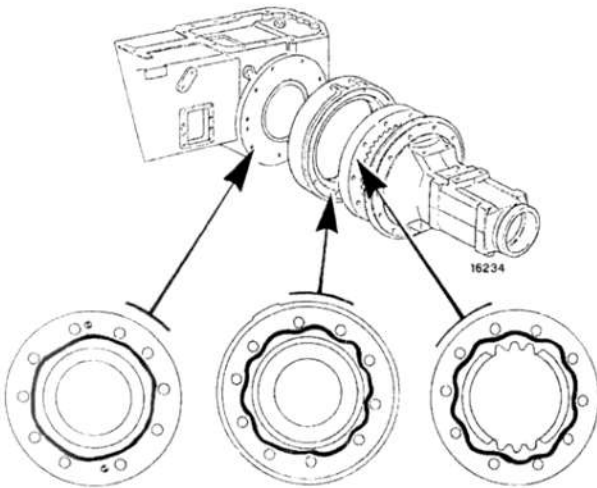

### Jointing compound application scheme for installation of side final drive cases onto transmission housing.

For Types of jointing compound, refer to page 6, Sect. A, Mods. 466/566/666/766.

**REMOVAL**



Raise and handle all components using a suitable hoist. Ensure that units or parts are supported by suitable slings or hooks. Ensure that no one is in the vicinity of the load to be lifted.

Remove final drives as follows:

- Drain oil from rear drive housing.
- Position a support stand under drive housing and take down the ROPS frame, wheels, fenders and footboards.
- Remove stud nuts (C<sub>1</sub>) and take down the final drive housing complete with bevel ring gear.

**DISASSEMBLY**



Handle all parts with extreme care. Do not put hands and fingers between parts. Wear safety items such as goggles, gloves and shoes.

Proceed as follows:

- Remove planet gear carrier (4) by first taking out lock washer (14) and screw (C<sub>2</sub>); pickup shim (S).

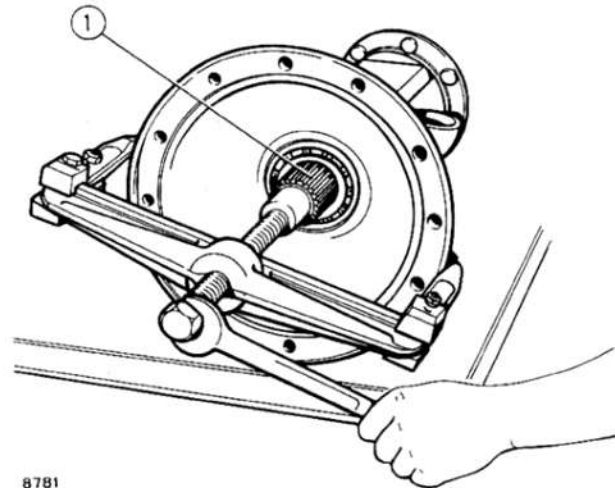

8781

**Removing wheel shaft using universal puller.  
1. Wheel shaft.**

- Using a universal puller, take out wheel drive shaft (1).
- Open retaining ring (10), take out planet gear journal (5) and planet gears (7); pickup needle roller bearings (8).

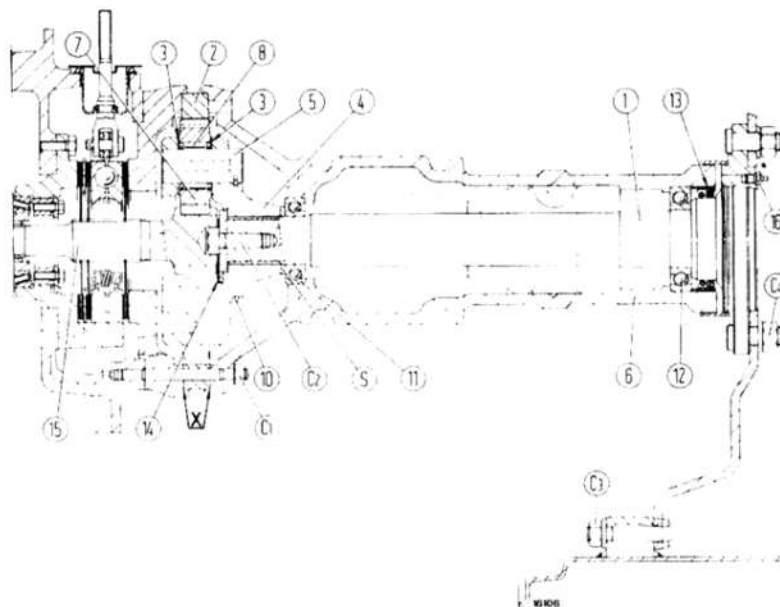

**RH final drive longitudinal section.**

C<sub>1</sub>. Nuts, final drive housing studs - C<sub>2</sub>. Lock screw, wheel drive shaft - C<sub>3</sub>. Nut, sheet metal disc-to-driving wheel rim screw - C<sub>4</sub>. Screw, sheet metal disc to driving wheel hub - G. = 0.2 to 0.4 mm (0.0078 to 0.0157 in). Planet gear carrier end play - S. Shims, end play (G) adjustment - 1. Wheel drive shaft - 2. Ring gear - 3. Thrust washers - 4. Planet gear carrier, epicyclic final drives - 5. Planet gear journal - 6. Final drive housing - 7. Planet gear - 8. Needle roller bearing - 10. Retaining ring, planet gear journals - 11. and 12. Ball bearings - 13. Seal - 14. Lock washer, screw (C<sub>2</sub>) - 15. RH sun gear shaft - 16. Grease fitting.

**Note** - On assembly, apply jointing compound to surfaces X as instructed on page 6, Sect. A, for Mods. 466/566/666/766.

## POWER TRAIN: Brakes

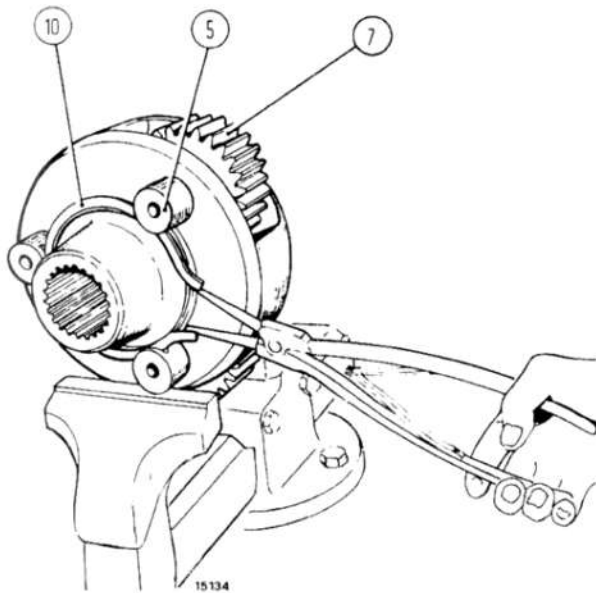

### Removing (installing) planet gear journals.

5. Journals - 7. Planet gears - 10. Retaining ring.

If necessary, replace seal (13) using a suitable driver to position the new seal at the correct depth.

### ASSEMBLY

Place housing in upright position and assemble noting the following points:

- Following seal (13, page 1) assembly, insert wheel shaft and press on flange until shaft is flush with bearing (12).

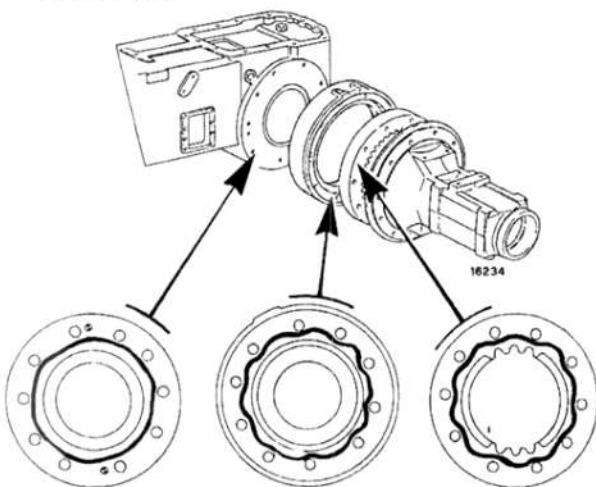

### Applying jointing compound for final drive installation on drive housing.

Jointing compound types are indicated on page 6, section A, for Mods. 466/566/666/766.

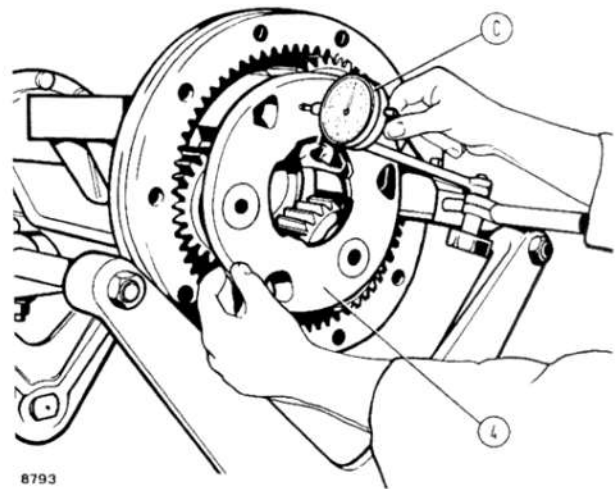

### Checking planet carrier end play.

C. Dial gauge - 4. Planet carrier.

- Position bearing (11) and install planet carrier (4) with shim (S).

- Tighten screw (C<sub>2</sub>, page 1) to the specified torque and check that carrier end play (G) is 0.2 to 0.4 mm (.007 to .015 in). To adjust, change shim (S).

### ⚠ WARNING ⚠

Use suitable tools to align holes. NEVER USE HANDS OR FINGERS.

Before installing final drive housing rear drive housing, and cover on final drive housing, thoroughly clean and degrease mating surfaces and apply a 2 mm (0.08 in) bead of jointing compound as shown in Figure alongside.

Jointing compound types are indicated on page 6, section A, for Mods. 466/566/666/766.

Tighten screws (C<sub>1</sub>, page 1) to the specified torque and inject **fiat TUTELA G9 grease** through lubricator (16) until it issues from inner shield.

Turn hub to ensure that lubricant is evenly distributed.

**DEAD FRONT AXLE**

Type .....	Inverted U, telescoping, centre pivoting
Track settings: six .....	1410 - 1510 - 1610 - 1710 - 1810 1910 mm (55 <sup>1</sup> / <sub>2</sub> - 59 <sup>1</sup> / <sub>2</sub> - 63 <sup>1</sup> / <sub>2</sub> - 67 <sup>1</sup> / <sub>2</sub> - 71 <sup>1</sup> / <sub>2</sub> 75 <sup>1</sup> / <sub>2</sub> in)
Camber .....	2°, equivalent to 15 mm (0.590 in) for 16 in rims, 18 mm (0.709 in) for 20 in rims at outermost edge of rim
Toe-in .....	0 to 5 mm (0 to 0.197 in)

**Steering Knuckle Articulation** - See page 1, Sect. 30, Mods. 466/566/666/766.

**Axle Pivot** - See page 1, Sect. 30, Mods. 466/566/666/766.

**POWER STEERING**

Type .....	Hydrostatic
Make .....	DANFOSS
Hydraulic circuit .....	Independent, separate pump
Oil reservoir .....	Transparent plastic on R.H. side of engine
Oil filter .....	In oil reservoir, gauze
<b>Hydraulic pump</b>	
Type .....	Gear
Model .....	C 25
Make .....	FIAT
Drive .....	From engine valve gear
Rotation (seen from drive side) .....	Clockwise
Drive ratio .....	0.931 to 1

**NOTE** - For operation and construction data regarding the **FIAT C 25** hydraulic pump, see pages 1 and 2, Sect. 30, Mods. 55-66/60-66/70-66/80-66.

## FRONT AXLE - STEERING: Specifications and Data

### POWER STEERING

Control Valve .....	DANFOSS
Type .....	with steering column operated rotary valve (permitting steering also in case of pump failure)
Outfit code: — DANFOSS (with valves in control valve) .....	OSPC 100
Relief valve crack-off setting .....	100 bar (102 kg/cm <sup>2</sup> , 1471.77 psi)
Power cylinder overload valve crack-off setting .....	200 bar (204 kg/cm <sup>2</sup> , 2903.53 psi)
Power Cylinder:	
Type .....	Double acting, located behind front axle
Make:	
— 55-66LP/60-66LP/70-66LP .....	SIMA or WEBER or ERBER
— 55-66DTLP/60-66DTLP/70-66DTLP .....	SIMA or WEBER or LAVERDA or GEA
Cylinder bore diameter:	
— 55-66LP/60-66LP/70-66LP .....	48 mm (1.88 in)
— 55-66DTLP/60-66DTLP/70-66DTLP .....	48 mm (1.88 in)
Piston rod diameter:	
— 55-66LP/60-66LP/70-66LP .....	22 mm (.866 in)
— 55-66DTLP/60-66DTLP/70-66DTLP .....	22 mm (.866 in)
Maximum piston stroke .....	215 mm or 8.46 in (214 mm or 8.42 in SIMA)
— 55-66LP/60-66LP/70-66LP .....	215 mm or 8.46 in (214 mm or 8.42 in SIMA)
— 55-66DTLP/60-66DTLP/70-66DTLP .....	200 mm (7.87 in)

**LIVE FRONT AXLE**

Type .....	Steering, full-floating, center pivoting
<b>Bevel Drive and Differential</b>	
Bevel drive ratio .....	10/36 = 1 to 3.6
Bevel drive backlash .....	0.15 to 0.20 mm (0.006 to 0.008 in)
Bevel pinion bearing shim thickness (S <sub>1</sub> , page 1, Sect. 402) .....	2.50 - 2.55 - 2.60 - 2.65 - 2.70 - 2.75 2.80 - 2.85 - 2.90 - 2.95 - 3 - 3.05 3.10 - 3.15 - 3.20 - 3.25 - 3.30 - 3.35 3.40 - 3.45 - 3.50 - 3.55 - 3.60 - 3.65 3.70 mm (0.098 - .100 - .102 - .104 - .106 .108 - .110 - .112 - .114 - .116 - .118 .120 - .122 - .124 - .126 - .128 - .130 .132 - .134 - .136 - .138 - .140 - .142 .144 - .146 in)
Bevel pinion shim thickness (S <sub>2</sub> ) .....	2.5 - 2.6 - 2.7 - 2.8 - 2.9 - 3.0 - 3.1 3.2 - 3.3 - 3.4 - 3.5 - 3.6 - 3.7 mm (0.098 - 0.102 - 0.106 - 0.110 - 0.114 0.118 - 0.122 - 0.126 - 0.130 - 0.134 0.138 - 0.142 - 0.146 in)
Differential pinion and side gear backlash .....	0.15 mm (0.006 in)
Side gear thrust washer thickness (7, page 1, Sect. 402) .....	1.470 to 1.530 mm (0.0579 to 0.0602 in)
Differential pinion thrust washer thickness (6) .....	1.50 - 1.60 mm (0.0590 - 0.0630 in)
Differential pinion journal dia. ....	21.939 to 21.960 mm (0.864 to 0.865 in)
Differential pinion bore dia. ....	22.040 to 22.061 mm (0.868 to 0.869 in)
Side gear spigot diameter .....	37.961 to 38.000 mm (1.494 to 1.496 in)
Side gear spigot bore diameter in differential case .....	38.080 to 38.119 mm (1.499 to 1.501 in)
Side gear spigot clearance in differential case .....	0.080 to 0.158 mm (0.003 to 0.005 in)
<b>Axle Shaft and Joints</b>	
Axle shaft journal diameter (5, page 1, Sect. 402) at bush (14) .....	29.914 to 29.935 mm (1.178 to 1.179 in)
Axle bushing fitted I.D. (14) .....	30.050 to 30.105 mm (1.183 to 1.185 in)
Axle shaft running clearance in bushing .....	0.115 to 0.191 mm (0.004 to 0.007 in)
Bushing interference fit in housing .....	0.064 to 0.129 mm (0.003 to 0.005 in)
Kingpin bearing shim thickness (S <sub>2</sub> , page 1) Sect. 402 .....	0.10 0.15 - 0.20 - 0.25 - 0.30 mm (0.004-0.006-0.008-0.010-0.012 in)
<b>Epicyclic Final Drives</b>	
Reduction ratio .....	15 to (15 + 54) = 1 to 4.6
Planet gear thrust washer thickness (18, page 1, Sect. 402) .....	0.77 to 0.83 mm (0.030 to 0.033 in)

## FRONT WHEEL DRIVE: Specifications and Data

### LIVE FRONT AXLE

(continued)

Centre Pivot .....	Refer to tabulation on page 2, Sect. 40, Mods. 466/566/666/766 which applies
--------------------	--

### AXLE DRIVE

Reduction ratio .....	34/34 to 24/34
Relay lever pad width .....	7.910 to 8.000 mm (0.3114 to 0.3149 in)
Pad seat width in driven gear .....	8.280 to 8.370 mm (0.3260 to 0.3295 in)
Pad clearance in seat .....	0.280 to 0.460 mm (0.0110 to 0.018 in)
Relay lever pivot diameter .....	15.973 to 16.000 mm (0.6288 to 0.6299 in)
Pivot housing bore in casing .....	16.016 to 16.059 mm (0.6305 to 0.6322 in)
Pivot clearance in housing .....	0.016 to 0.086 mm (0.0006 to 0.0034 in)
Relay lever detent spring height	
— Free .....	130 mm (5.118 in)
— Under 299 to 330 N (30.5 to 33.7 kg or 67 to 74 lb) .....	142.5 mm (5.610 in)

### DRIVE SHAFT

Refer to tabulation on page 2, Sect. 40, Mods. 466/566/666/766 which applies.

### TORQUE DATA

Refer to tabulation on page 3, Sect. 40, Mods. 466/566/666/766 except as indicated below.

Item	Thread size	Torque		
		Nm	kgm	lb ft
<b>Live Front Axle - Sect. 402</b>				
Bevel drive pinion lock ring nut (C <sub>1</sub> , page 1) .....	M35x1.5	294	30	217
Wheel hub bearing lock ring nut (C <sub>6</sub> ) .....	M45x1.5	118	12	86
Steering wheel disc to hub screw .....	M16x1.5	255	26	188

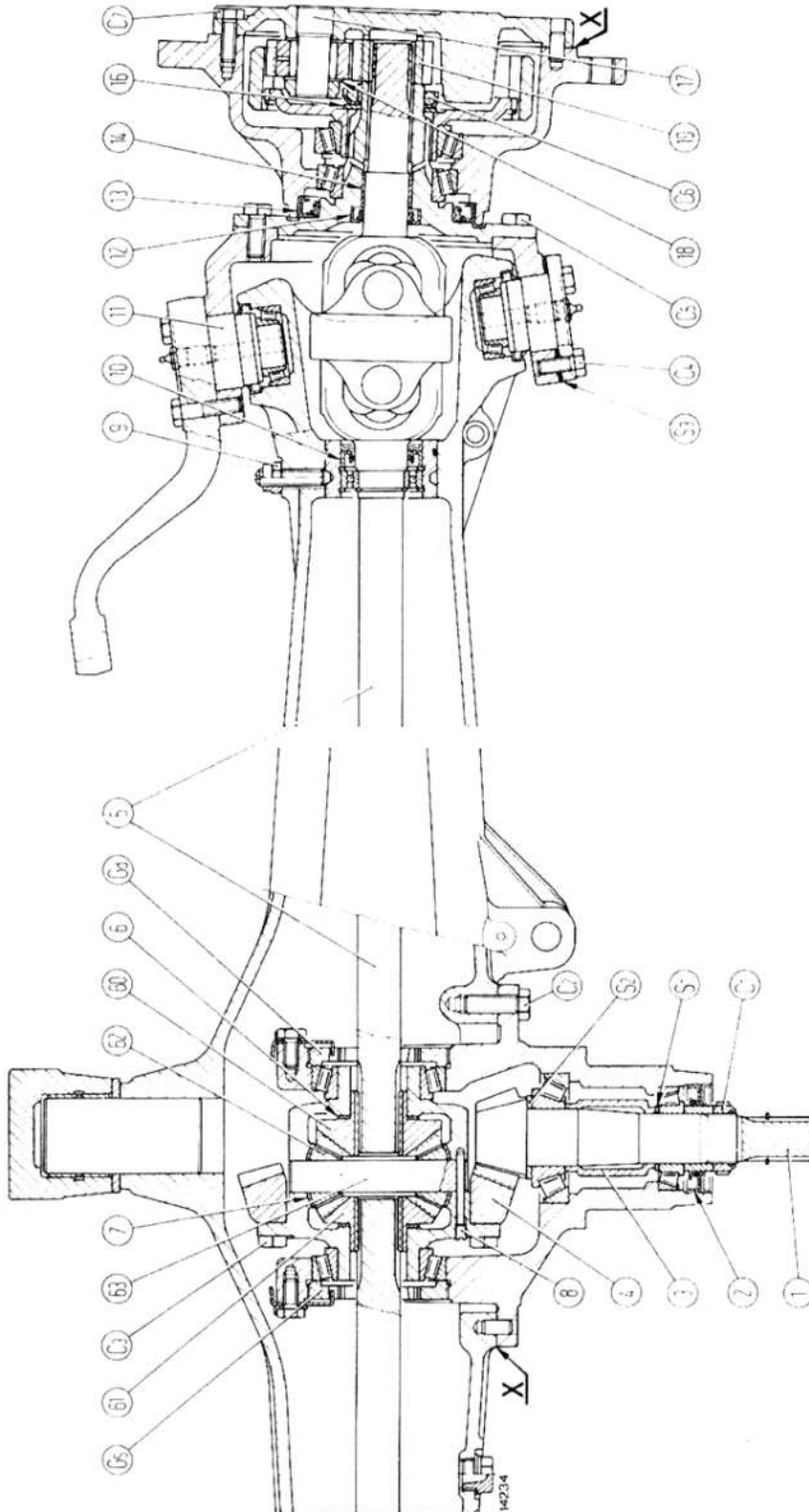

R, H, and L, H, differential bearing lock ring - S, Bevel pinion bearing shim - S<sub>2</sub>, Bevel pinion position shim - S<sub>3</sub>, King pin bearing shims - 1, Bevel pinion - 2, Seal - 3, Bevel pinion bearing spacer - 4, Ring gear - 5, Axle shaft with universal joint - 6, Side gear washers - 7, Differential pinion washers - 8, Differential pinion journal screw - 9, Bearing carrier screw - 10, Seal - 11, King pin bearing - 12 and 13, Seals - 14, Axle shaft bushing - 16, Thrust washer - 17, Planet wheel journals - 18, Planet wheel shims - 19, Sun gear - 60 and 61, Side gears - 62, Differential pinion - 63, Differential pinion journal.

**Live front axle longitudinal section**  
**Note** - On assembly, thoroughly clean and degrease mating surfaces **X** and apply one of jointing compounds listed on page 6, Sect. A, Mods. 466/566/666/766.

C<sub>1</sub>, Bevel pinion bearing lock ring - C<sub>2</sub>, Differential carrier screw - C<sub>3</sub>, Ring gear screw - C<sub>4</sub>, King pin bearing screw - C<sub>5</sub>, Steering knuckle screw - C<sub>6</sub>, Wheel hub bearing lock ring - C<sub>7</sub>, Final drive housing screw - Gd and Gs.

# FRONT WHEEL DRIVE: Sections

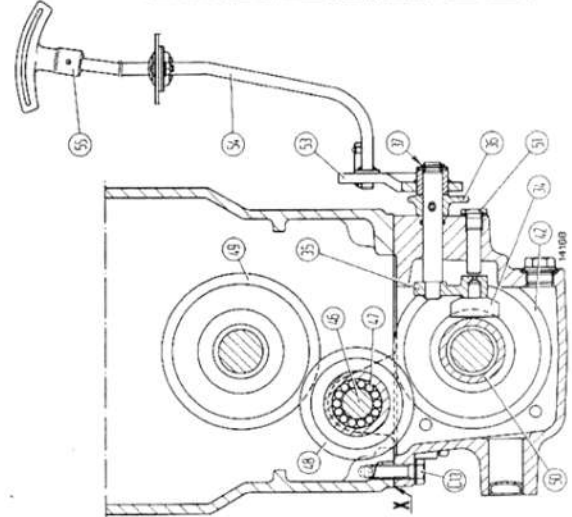
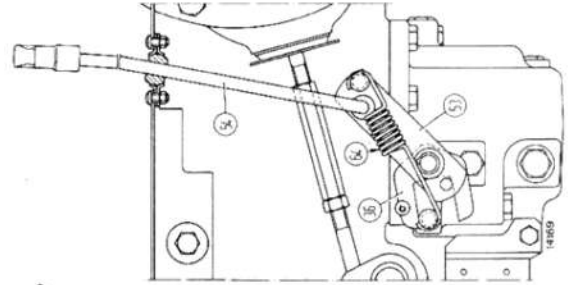
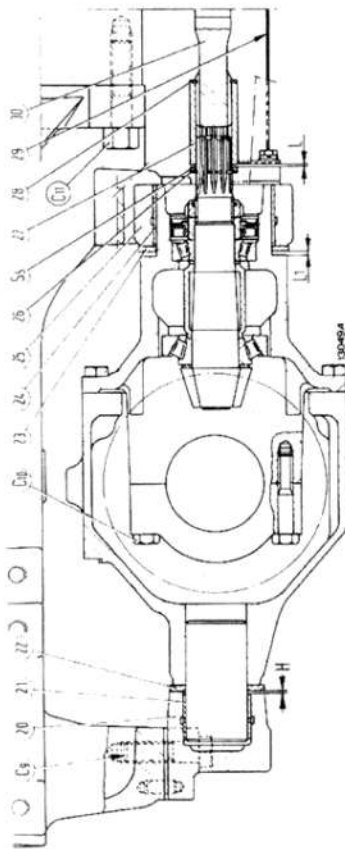
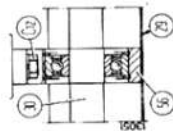
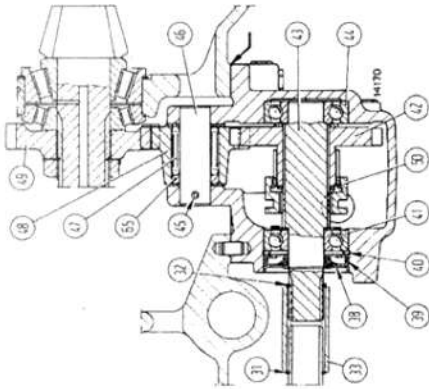

**Longitudinal section through axle pivot, axle drive and drive shaft.**

**Note** - On assembly, thoroughly clean and degrease mating surfaces **X** and apply one of jointing compounds listed on page 6, Sect. A, Mods. 466/566/666/766.

- C<sub>10</sub>. Axle housing pivot front/rear support screws - C<sub>10</sub>. Differential bearing cap screw - C<sub>11</sub>.
- Front axle support-to-engine screws - C<sub>12</sub>. Drive shaft center bearing block screw - C<sub>13</sub>.
- Axle drive housing screws - H = 1 mm (0.04 in) Front bushing fitted stand-in - L = 1 to 1.5 mm (0.04 to 0.06 in) Sleeve end play - S<sub>s</sub>. Sleeve (27) positioning shim - 20. Axle front pivot support - 21. Front bushing - 22. Front thrust washer - 23. Rear thrust washer - 24. Rear bushing - 25. Axle rear pivot support - 26 and 28. Retaining rings - 27. Front splined sleeve - 29. Drive shaft guard - 30. Drive shaft - 31 and 32. Retaining rings - 33. Rear splined sleeve - 34. Shoe - 35. Inner relay lever - 36. FWD engagement fork - 37. Retaining ring - 38. Dust excluder - 39. Seal - 40. Retaining ring - 41. Ball bearing - 42. Driven gear - 43. Splined driven shaft - 44. Ball bearing - 45. Roll pin - 46. Intermediate shaft - 47. Needle roller bearing - 48. Intermediate gear - 49. Drive gear keyed on bevel pinion - 50. Axle engagement sleeve - 51. Plug - 53. Axle drive control lever - 54. Vertical link - 55. Hand lever - 56. Pillow block complete with ball bearing - 64. FWD IN/OUT lever detent spring - 65. Needle roller bearing spacer.

**LIFT**

Type .....		Position, draft and mixed control
Control .....		Two independent levers
Variospeed sensitivity adjustment .....		Control valve-mounted, 4-position lever
LIFT-O-MATIC .....		Link raising / lowering by fast-acting buttons without use of hand control levers
Response adjustment .....		Knob on control valve
Single-acting cylinder:		
— Bore x stroke	{ Models 55-66LP and 60-66LP .....	100x128 mm (3.9x5.0 in)
	{ Models 70-66LP .....	110x128 mm (4.3x5.0 in)
— Displacement	{ Models 55-66LP and 60-66LP .....	1005 cm <sup>3</sup> (155.8 in <sup>3</sup> )
	{ Models 70-66LP .....	1216 cm <sup>3</sup> (188.4 in <sup>3</sup> )
Relief valve crack-off setting .....		186 to 191 bar (190 to 195 kg/cm <sup>2</sup> , 2.702 to 2.773 psi)
Safety valve crack-off setting .....		210 to 215 bar (214 to 219 kg/cm <sup>2</sup> , 3.043 to 3.114 psi)
Design lift capacity	{ Models 55-66LP and 60-66LP .....	18944 N (1932 kg or 4250 lb)
	{ Model 70-66LP .....	22922 N (2337 kg or 5140 lb)
Lift piston dia.	{ Models 55-66LP and 60-66LP .....	99.980 to 100.000 mm (3.9362 to 3.937 in)
	{ Models 70-66LP .....	109.980 to 110.000 mm (4.3299 to 4.3307 in)
Lift cylinder bore dia	{ Models 55-66LP and 60-66LP .....	100.036 to 100.071 mm (3.9384 to 3.9398 in)
	{ Models 70-66LP .....	110.036 to 110.071 mm (4.3321 to 4.3335 in)
Piston working clearance in bore .....		0.036 to 0.091 mm (0.0014 to 0.0036 in)

**Note** - For lift component design data refer to tabulations on pages 1 and 2, Sect. 50, covering Mods. 466/566/666/766 except as listed below:

Non-return (check) valve return spring:	
— Free length .....	23.5 mm (0.925 in)
— Height under a load of 35.3 to 39.2 N (3.6 to 4 kg or 8 to 9 lb) . .	18 mm (0.70 in)

## HYDRAULIC LIFT UNIT: Specifications and Data

### IMPLEMENT ATTACHMENT

Type .....	3-point linkage
Category .....	One and Two
Draft control .....	Through lower links and sensing bar
Max. lift capacity, center of gravity 610 mm (24 in) from lower link bushings and starting with links horizontal (top link coupled to top hole):	
— Models 55-66LP and 60-66LP .....	2275 daN (2320 kg or 5104 lb)
— Models 70-66LP .....	2746 daN (2800 kg or 6160 lb)
Max. lift capacity, starting with lower links horizontal (top link coupled to top hole):	
— Model 55-66LP: center of gravity 1050 mm or 41.3 in from lower link swivel bushings: .....	1892 daN (1930 kg or 4296 lb)
— Model 60-66LP: center of gravity 1090 mm or 42.9 in from lower link swivel bushings: .....	1863 daN (1900 kg or 4180 lb)
— Model 70-66LP: center of gravity 1170 mm or 46.1 in from lower link swivel bushings: .....	2177 daN (2220 kg or 48884 lb)
Max. lower link end travel:	
— Lifting rods out and coupled to front mounting holes: .....	abt. 770 mm (30.3 in)
— Lifting rods out and coupled to rear mounting holes: .....	abt. 660 mm (26 in)

### REMOTE CONTROL VALVE

Refer to the data in tabulation on pages 4 and 5, Sect. 50, Mods. 466/566/666/766 which apply.

## REMOVAL



Lift and handle all heavy components using a suitable hoist. Ensure that units or parts are supported by suitable slings or hooks. Ensure that no one is in the vicinity of the lifted load.

Proceed as follows:

- Disconnect the battery negative cable.
- Drain the fuel tank.
- Take off fuel tank rear guards, disconnect the fuel level indicator wiring and tank fuel outlet lines.
- Take down the fuel tank after having backed out its screws from mounting brackets.
- Disconnect lift arms from implement carrier.
- Disconnect the remote control valve coupling support plate and the top link support from lift body.
- Disconnect the remote control valve oil lines and associated mounting bracket.
- Disconnect the position/draft control linkage rods and the LIFT-O-MATIC flexible control.
- Backoff the screws securing lift unit to rear drive housing and, using hoist and sling, take down the lift unit being careful to avoid interference of draft control rod with lift lever linkages.

## DISASSEMBLY



Handle all components with care. Do not put hands and fingers between parts. Wear safety goggles, gloves and shoes.

Secure lift on service stand and proceed with the disassembly minding the following:

**Note** - To install the lift on revolving stand make a plate with holes and dimensions as shown in the Figure on page 3, Sect. 501 Mods. 466/566/666/766.

Method used for plate mounting on stand will depend on stand configuration.

- Remove control valve assy after taking out its mounting screws.
- Remove lift control outer levers and relevant clutch plates after taking off nuts (C+) springs and bracket (1).

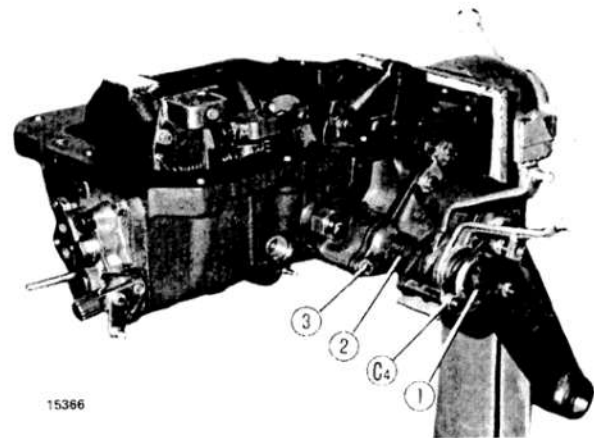

### Removing lift control outer levers.

C+. Spring bracket stud nuts - 1. Spring bracket - 2. Spacer - 3. Spacer screws.

- Remove screws (3) and spacer (2).
- Take off lifting arms and thrust washers.
- Remove the three screws securing cylinder (1) to lift housing and the two control valve lever support screws (3). Take off cylinder together with piston.
- Blow in compressed air through oil delivery port to eject the piston.
- Remove inner arm screws, insert protector **293384** over RH seal and remove cross shaft by tapping right end of shaft.
- Take inner levers out of lift body.
- Tractors not equipped with remote control valve: remove relief valve from lift body.

Disassemble control valve as described on page 5, Sect. 501, Mods. 466/566/666/766.

## INSPECTIONS - ASSEMBLY

Refer to the text and illustrations provided on pages 5, 6 and 7, Sect. 501, for Mods. 466/566/666/766.

**Note** - The illustration on page 2 showing the section through lift levers and controls substitutes the corresponding figure on page 6, Sect. 501, Mods. 466/566/666/766.

## LIFT ADJUSTMENT

The following adjustments refer to a lift without hydraulic control valve and placed on work bench or secured to a rotary stand through a suitable bracket.

## HYDRAULIC LIFT UNIT: Lift

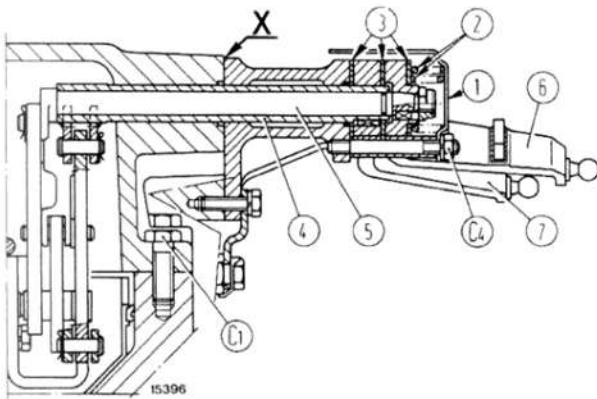

### Section through lift levers and controls.

C1. Lift screw - C4. Spring bracket stud nuts - 1. Spring bracket - 2. Springs - 3. Clutch plates - 4. Position lever pin - 5. Draft lever inner shaft - 6. Position outer lever - 7. Draft outer lever.

Adjust in the order given.

With lift installed on tractor, only arm upward travel adjustment is possible.

Unless otherwise indicated, LIFT-O-MATIC must be deactivated, i.e. external control lever must be locked in upright position.

### 1. Position control adjustment

Proceed as follows:

- Move position control lever (37), fully forward to contact spring bracket spacer and draft control lever (38) fully back against spacer.

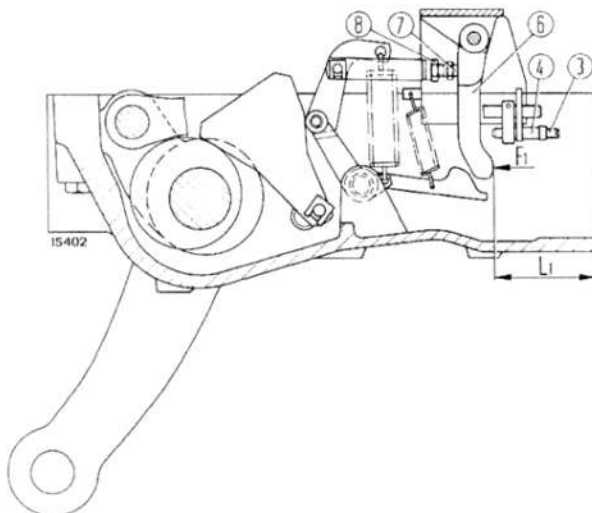

- Rotate cross shaft to bring inner arm in contact with lift body.
- Using wrench **293870** (C, page 9) slacken locknut (4) and travel adjusting screw (3) until screw no longer touches lever (6).
- Install tool **293846** (A, page 3) on lift body.
- Using wrenches (1 and 2), back off locknut (8) and tighten or slacken adjustable link rod (7) so that plunger ( $P_1$ ) is aligned with outer register ( $R_1$ ) of tool (A) as shown.

**Note** - This condition corresponds to a gap ( $L_1$ ) of 82 to 82.1 mm (3.22 to 3.23 in) between lever end (6) and lift body front face measured applying a force ( $F_1$ ) of 4 to 4.5 daN (kg) or 9 to 10 lb to lever end.

- Tighten locknut (8).
- Move position control lever (37) fully back on quadrant to contact spacers, rotate cross shaft to bring piston fully forward and check that plunger ( $P_1$ ) of tool **293846** (D, page 3) is retracted by 1.3 to 1.7 mm (0.0512 to 0.0670 in) with respect to register ( $R_2$ ) of same tool.

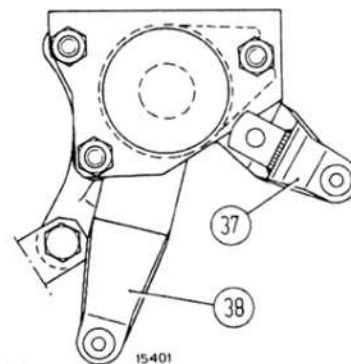

### Adjusting position control.

$F_1$  = 4 to 4.5 daN (kg) or 9 to 10 lb. Force applied by tool **293846** on lever (6) -  $L_1$ . Distance between lever end (6) and lift body front end - 3. Limit travel adjusting screw - 4. Locknut - 6. Control valve lever - 7. Link cap - 8. Locknut - 37. Outer position control lever - 38. Outer draft control lever.

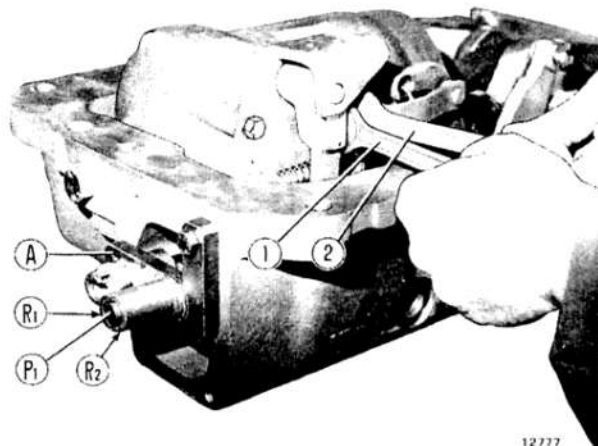
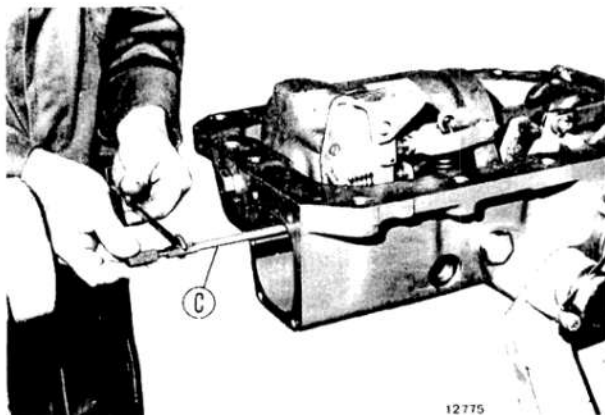

**Adjusting position control.**

A. Tool **293846** - C. Wrench **293870** - P<sub>1</sub>: Moving plunger - R<sub>1</sub>: Outer register - R<sub>2</sub>: Inner register - 1 and 2. Wrenches.

**Note** - This condition corresponds to a gap (L<sub>1</sub>, page 2) between lever end (6) and lift body front end of 86.3 to 86.7 mm or 3.39 to 3.41 in when measured applying a force (F<sub>1</sub>) of 4 to 4.5 daN (kg) or 9 to 10 lb on lever end.

**Note** - If early model tool **293845** is available, it may be changed into late model **293845/1** by modifying spindle (S) as shown in Fig. on page 1, Sect. 501, Mods. 55-66, 60-66, 70-66.

**2. Maximum lift arm travel adjustment on bench**

Proceed as follows:

- With tool **293846** (A) installed on lift body, position draft control lever (38, page 2) fully back on quadrant to contact spacer and position control lever (37) fully forward against spacer.
- Rotate cross shaft to bring inner arm into contact with lift body.
- Hook up connection (R<sub>3</sub>) on tool (A) to a compressed air source (T) and introduce air to cylinder so that piston moves, through full lift stroke. Maintain air pressure to keep piston in this position.
- Using wrench **293870** (C), tighten screw (3, page 2) until end of plunger (P<sub>1</sub>), is recessed from inner register (R<sub>2</sub>) of tool (A) or by 1.3 to 1.7 mm (0.051 to 0.067 in).

**Note** - This condition corresponds to a gap (L<sub>1</sub>, page 2) of 86.3 to 86.7 mm (3.39 to 3.41 in) between lever end (6) and lift body front end.

- Tighten locknut (4).

**3. Draft control adjustment**

**Important** - Draft control must be adjusted using tool **293846** along with **293845/1**.

Proceed as follows:

- Remove end of draft control rod (19, page 4 ) and install on spindle (S) of tool **293845/1** securing through lock nut (25).
- Place tool **293845/1** (B) together with spindle (S) and end of draft control rod (19) on a surface plate and measure gap (L<sub>6</sub>) between top of spindle and support face of depth gauge (M).

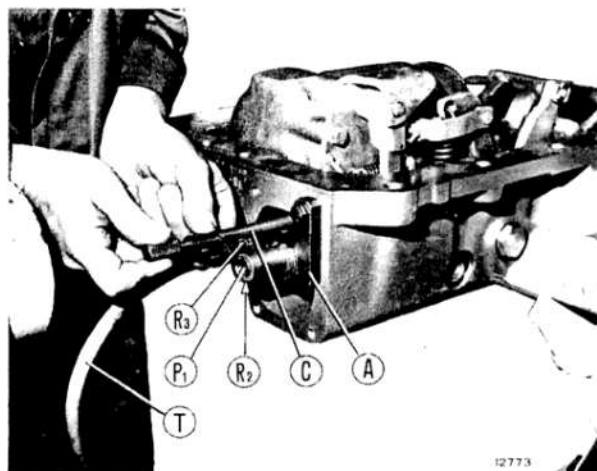

**Adjusting maximum lift arm travel on bench.**

A. Tool **293846** - C. Wrench **293870** - P<sub>1</sub>: Plunger - R<sub>2</sub>: Inner register face - R<sub>3</sub>: Compressed air connection - T. Compressed air line.

# HYDRAULIC LIFT UNIT: Lift

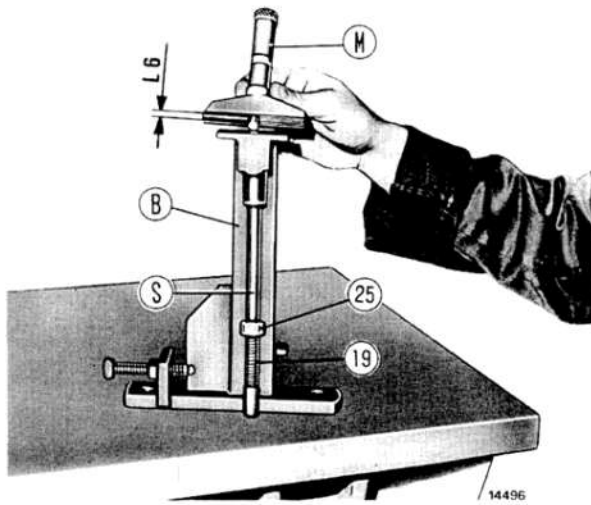

### Zeroing tool 293845/1 (B) for draft control adjustment.

L<sub>6</sub>. Gap between top of spindle (S) and depth gauge support face - M. Depth gauge - S. Spindle - 19. Draft control rod - 25. Lock nut.

(Turn in item (10) on spindle (S) so that the face of the latter is located a few mm lower than gauge support face on tool).

Next proceed as follows:

- With tool 293846 (A, page 3) installed on lift body and disconnected from compressed air supply, move

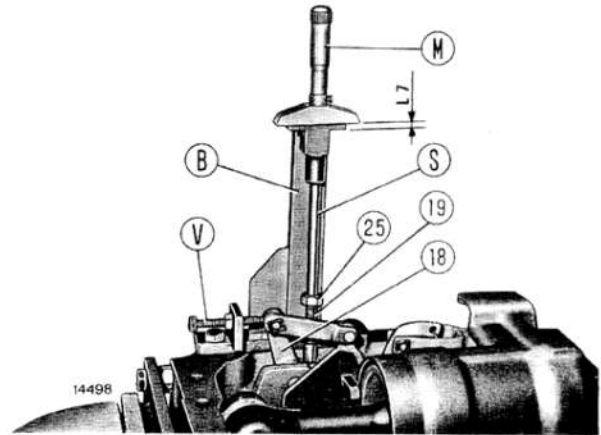

### Adjusting draft control.

B. Tool 293845/1 - L<sub>7</sub>. Gap between top of spindle and depth gauge support face - M. Depth gauge - S. Spindle - V. Screw - 18. Draft control inner lever - 19. Draft control rod - 25. Lock nut.

position control lever (37) and draft control lever (38) fully back to contact spacer.

- Locate cam pin (32, page 5) securing draft control inner lever in horizontal position with cam facing lift rear end.
- Install tool 293845/1 (B), on lift body and secure to two housing holes as shown in figure above. Turn knurled screw (V) to move draft control inner lever (18) until end of plunger (P<sub>1</sub>, page 3) is exactly aligned to outer register (R<sub>2</sub>) on tool 293846 (A).

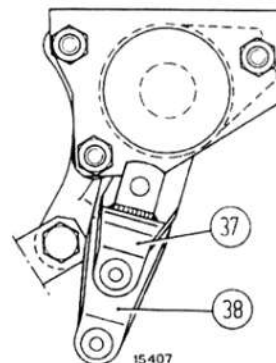
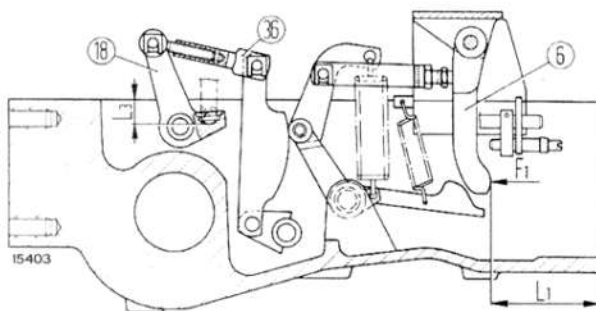

### Adjusting draft control.

F<sub>1</sub> = 4 to 4.5 da N (kg) or 9 to 10 lb. Force applied to lever (6) by tool 293846 - L<sub>1</sub> = 81.9 to 82.1 mm (3.22 to 3.23 in). Distance between end of lever (6) and lift body front face - L<sub>2</sub> = 23.9 to 24.1 mm (0.940 to 0.948 in) Distance between lift housing mating face on transmission housing and rod contact face on lever (18) - 6. Control valve actuating lever - 18. Draft control inner lever - 37. Position control outer lever - 38. Draft control outer lever.

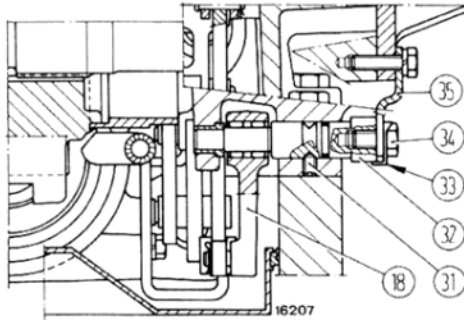

**Section through draft control inner lever linkage.**

31. Threaded dowel - 32. Lever cam - 33. Lock washer - 34. Screw - 35. Bracket.

- Rotate cam (32) slightly to retract end of plunger of tool **293846** as far back as possible.
- Turn screw (V, page 4) again to move lever (18) until end of plunger is aligned with inner register (R<sub>2</sub>, page 3) of tool **293846**.
- Rotate cam (32) as necessary to align end of plunger with outer register (R<sub>1</sub>, page 3).

Then proceed as follows:

- Insert spindle of tool **293845/1** (B, page 4) in seat of draft control inner lever (18).
- With end of plunger in line with outer register (R<sub>1</sub>, page 3) move link (36, page 4) and measure distance (L<sub>7</sub>) with depth gauge (M, page 4) between top of spindle and depth gauge support face on tool **293845/1**.
- Dimension (L<sub>7</sub>, page 4) will be given by:

$$L_7 = L_6 + L_3$$

where:

**L<sub>6</sub>** = dimension measured with tool **293845/1** on surface plate.

**L<sub>3</sub> = 23.9 to 24.1 mm (0.940 to 0.948 in)** Distance between lift housing mating face on rear drive housing and rod contact face on lever (18).

**Note** - This condition corresponds to a gap (L<sub>1</sub>, page 4) of 81.9 to 82.1 mm (3.224 to 3.232 in) between lever end (6) and lift body front face measured applying a force (F<sub>1</sub>) of 4 to 4.5 da N or 9 to 10 lb to lever end.

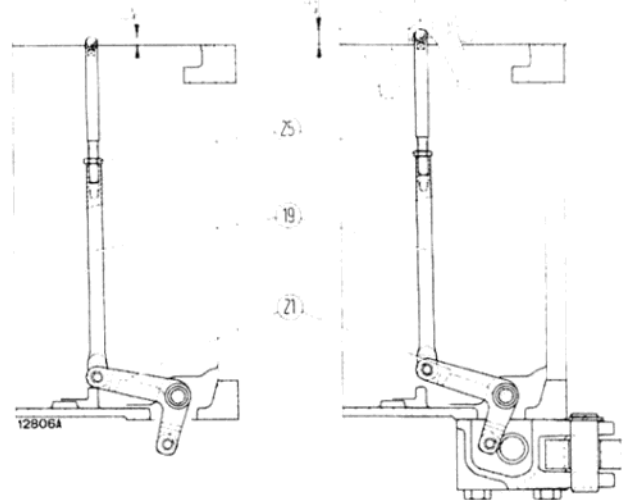

**Installation of lift on tractor.**

L<sub>4</sub>. Rod (19) top end stand out relative to drive housing (sensing bar removed) - L<sub>5</sub>. Rod (19) end stand out relative to drive housing (sensing bar installed) - 19. Draft control rod - 21. Draft control link lever - 25. Jam nut.

**Note** - Check that with plunger (P<sub>1</sub>, page 3), aligned with outer register (R<sub>1</sub>) of tool **293846** (A), dimension (L<sub>7</sub>, page 4) is as follows:

$$L_7 = L_6 + L_3$$

where:

**L<sub>6</sub>** = dimension measured with tool **293845/1** on surface plate.

**L<sub>3</sub> = 23.9 to 24.1 mm (0.940 to 0.948 in)** Distance between lift housing mating face on rear drive housing and rod contact face on lever (18). To adjust, turn cam (32) and knurled screw (V, page 4) or tool **293845/1**.

- Install threaded dowel (31) and tighten screw (34) without folding down lockwasher tab. (33).
- Disassemble tools **293846** and **293845/1** and install hydraulic control valve on lift body.

Install lift on tractor as described below:

**Warning** - First place tool **293845/1** (B) on a surface plate and, using a depth gauge (M) measure distance (L<sub>6</sub>) between tool base and depth gauge support face on tool. Stamp measured dimension (L<sub>6</sub>) on tool.

## HYDRAULIC LIFT UNIT: Lift

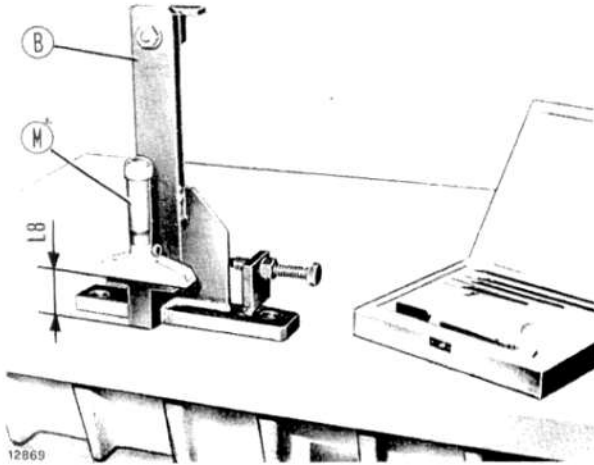

### Zeroing tool 293845/1 (B) for draft control adjustment.

$L_8$ . Dimension between tool base on surface plate and depth gauge support face (to be stamped on tool) - M. Depth gauge.

- Install draft sensing unit complete with relay lever (21, page 5) and draft control rod (19) but without sensing bar on rear drive housing.
- Rest relay lever (21) against sensing bar housing, install tool **293845/1** (B), securing it to two housing holes in such a way that draft control rod (19) fits perfectly into hole on tool as shown.
- Using depth gauge (M) measure distance ( $L_9$ ) between top of rod (19) and depth gauge support face on tool.

**Note** - Stand-out ( $L_4$ , page 5) of top rod end (19) from drive housing (with sensing bar removed) will be given by:

$$L_4 = L_8 - L_9$$

where:

$L_8$  and  $L_9$  = Dimensions measured with tool **293845/1** on surface plate ( $L_8$ ) or on drive housing ( $L_9$ ).

- Install sensing bar and measure new distance ( $L_{10}$ ) between top of rod (19) and depth gauge support face on tool.

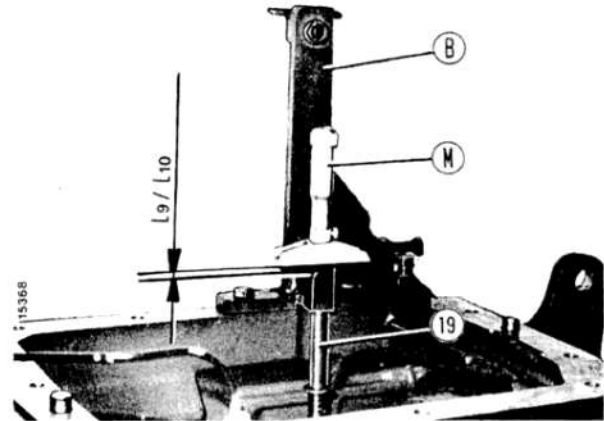

### Adjusting draft control.

B. Tool **293845/1** -  $L_9$ . Distance between top of rod (19) and depth gauge support face on tool (with sensing bar removed) -  $L_{10}$ . Distance between top of rod (19) and depth gauge support face on tool (with sensing bar installed) - M. Depth gauge - 19. Draft control rod.

**Note** - Stand-out ( $L_5$ , page 5) of rod end (19) from drive housing (with sensing bar installed) will be given by:

$$L_5 = L_8 - L_{10}$$

where:

$L_8$  and  $L_{10}$  = Dimensions measured with tool **293845/1** on surface place ( $L_8$ ) or on drive housing ( $L_{10}$ ).

- Check that dimension ( $L_5$ ) exceeds dimension ( $L_4$ ) by at least 5 mm (0.20 in).
- Slacken locknut (25, page 5) and adjust draft control rod length so that stand-out ( $L_5$ ) is 18.3 to 18.5 mm or 0.720 to 0.728 in.
- Stand-out ( $L_5$ ) may be determined using tool **293845/1** as follows:

$$L_{11} = L_8 - L_5$$

where:

$L_5$  = 18.3 to 18.5 mm (0.720 to 0.728 in). Stand-out of rod end from drive housing.

$L_8$  = Dimension measured with tool **293845/1** on surface plate.

$L_{11}$  = Dimension measured with depth gauge on tool **293845/1**.

- Tighten lock nut (25, page 5) and install lift on tractor.

### 4. Position control link adjustment

Proceed as follows:

- Move position control lever (P) upright on quadrant and check that distance ( $L_{12}$ ) between lever and beginning of slot is 11 mm or 43 in.

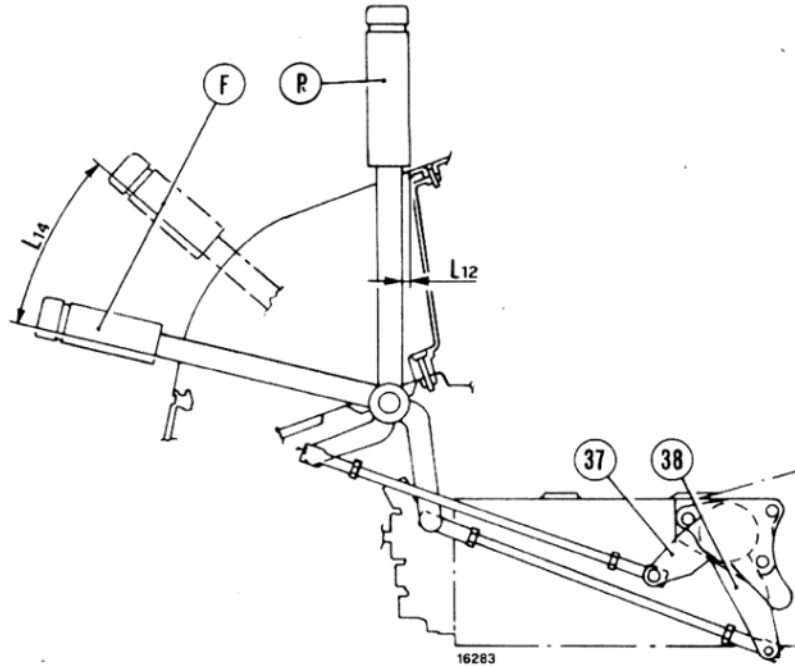

**Adjusting position (P) and draft (F) control levers.**

F. Draft control lever -  $L_{12}$  = 11 mm or .43 in. distance between position control lever (P) and beginning of slot -  $L_{14}$  = 185 to 195 mm or 7.28 to 7.67 in. Distance between beginning of slot and front edge of lever (F) - P. Position control lever - 37. Outer position control lever on lift - 38. Outer draft control lever on lift.

- Move outer lever (37) fully forward against spacer, connect link (adjusting length if necessary) and check that distance ( $L_{12}$ ) is 11 mm or .43 in.
- Secure link through jam nuts.
- If not, adjust lever cam (32, page 5) until distance ( $L_{14}$ ) is as specified.
- Secure cam (32) in position through dowel (31) and lock washer (33).

**5. Draft control link adjustment**

Test conditions:

- No additional weight on lower links.
- Engine mid acceleration.

Proceed as follows:

- Move lever (P) fully forward on quadrant (complete lowering).
- Move outer lever (38) fully back against spacer, and lever (F) forward on quadrant. Connect draft control link to levers (38) and (F). To adjust, alter length of link.
- Move draft control lever (F) to a distance  $L_{14}$  = 185 to 195 mm or 7.28 to 7.67 in along quadrant. With lever (F) in this position, check that arms begin to raise.

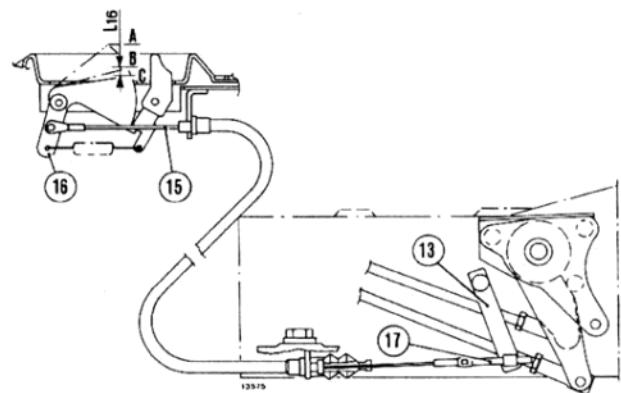

**Adjusting Lift-O-Matic.**

A = Rest position of pushbutton (16) - B = Pushbutton position at start of control valve exhaust - C = Pushbutton latch position -  $L_{16}$  = 9 to 12 mm or 0.35 to 0.47 in. Distance between pushbutton positions B and C - 13. Outer lever - 15. Cable - 16. Pushbutton - 17. Threaded end.

## HYDRAULIC LIFT UNIT: Lift

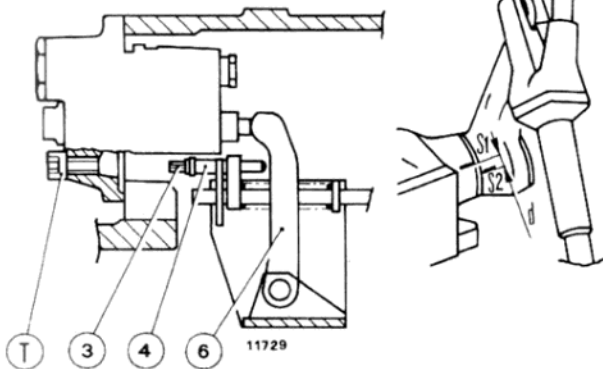

### Adjusting maximum lift arm travel.

$d = 2$  to  $3$  mm ( $0.08$  to  $0.12$  in). Distance between reference marks  $S_1$  and  $S_2$  -  $S_1$ . Reference mark on lift body -  $S_2$ . Reference mark on lift arm -  $T$ . Plug - 3. Travel adjusting screw - 4. Adjusting screw jam nut - 6. Control valve actuating lever.

### 6. Lift-O-Matic adjustment.

**Note** - Release lever (13, page 7) to reactivate Lift-O-Matic.

Proceed as follows:

- With engine off, move draft and position control levers (F and P) fully forward on quadrant.
- Connect cable (15) and pushbutton (16) to outer lever (13) and secure pushbutton assy to mud-guard.
- Start engine and accelerate to mid position.
- Adjust cable (15) through end (17) so that when pushbutton (16) is actuated, lift arms start to lower when pushbutton is still short of its full stroke by a distance  $L_{16}$  of  $9$  to  $12$  mm or  $0.35$  to  $0.47$  in as measured at end of pushbutton (see Figure on page 7).

- Secure end (17) to outer lever (13) through associated clip.

### 7. Maximum lift arm travel adjustment with lift installed on tractor

Test conditions:

- Apply  $50$  kg ( $100$  lb) to lower link swivel bushings.
- Bring oil temperature to  $50$ - $60^\circ\text{C}$  ( $112$  to  $140^\circ\text{F}$ ).

Proceed as follows:

- Shut off engine, wait  $5$  minutes to allow oil in lift body to drain into rear drive housing, remove plug (T) and insert wrench **293870** in plug hole.
- Start engine and run at  $1200$  to  $1500$  rpm.
- Raise links by applying the Lift-O-Matic.
- Using wrench **293870** slacken jam nut (4) and back off limit travel adjusting screw (3) until relief valve cracks off.
- Apply two corresponding reference marks on lift body ( $S_1$ ) and on one lift arm ( $S_2$ ).
- Using wrench **293870**, tighten adjusting screw (3) until distance ( $d$ ) between the two reference marks is  $2$  to  $3$  mm ( $0.08$  to  $0.12$  in).
- Tighten jam nut (4).
- Shut off engine, wait for approximately five minutes, remove wrench **293870** and reinstall plug (T).
- Operate lift through a few strokes to check that adjustment is correct.

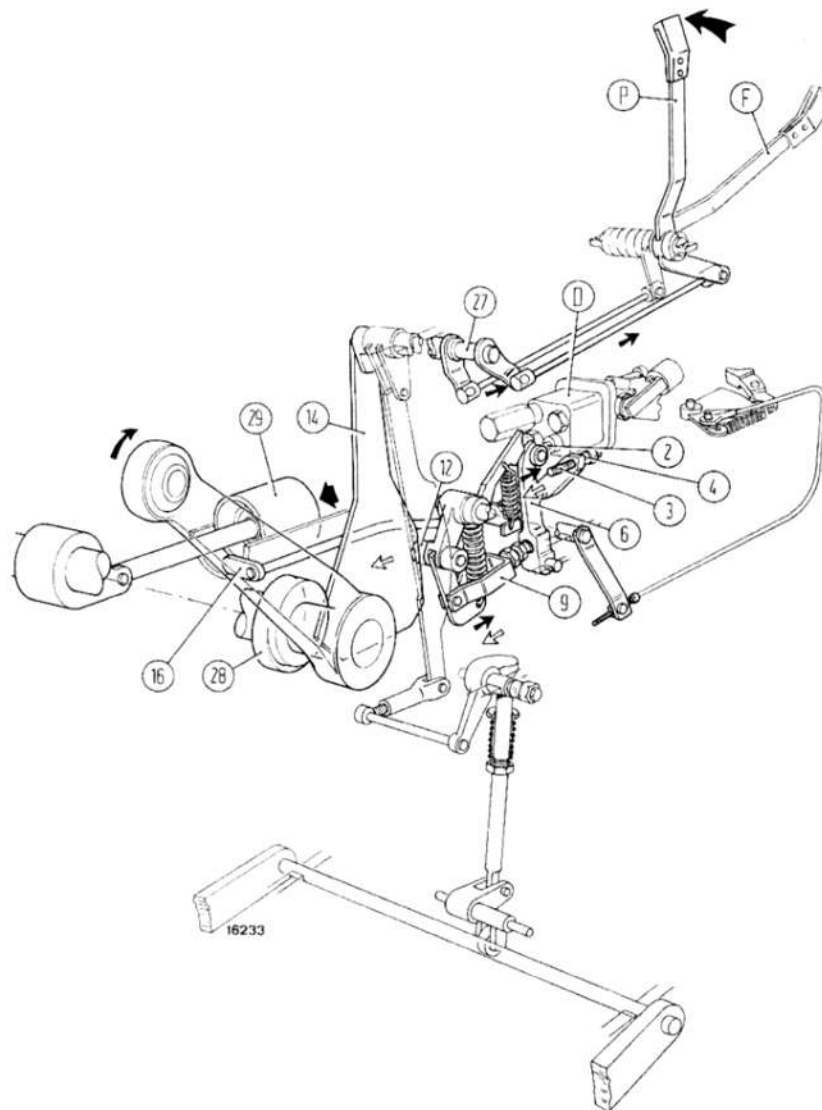

**CONTROL VALVE LINKAGE OPERATION  
SCHEMATICS**

Refer to the text and illustrations provided on page 16, Sect. 501, for Mods. 466/566/666/766.

The only substantial differences in Mods. **55-66LP/60-66LP/70-66LP** control linkages with respect to the counterpart schematics for Mods. 466/566/666/766 are that the position/draft control levers (P) and (F) are connected to the linkage by adjustable rods and that the LIFT-

O-MATIC device is present.

The above schematic illustrating the implement lift stage during position control operation shows the different connection of control levers (P) and (F). The new schematics for implement lifting under draft control conditions and increased tractive effort are not given here as they are practically identical with those shown on page 16, Sect. 501, Mods. 466/566/666/766, the only differences being the connection of control levers (P) and (F) and the inclusion of the LIFT-O-MATIC.

---

**501**

---

*page 10*

**HYDRAULIC LIFT UNIT:**

---

**FUSES**

Six 8 Amp and two 16 Amp fuses, housed in box.		
Fuses	PROTECTED CIRCUITS	Amp
1	Engine stopping solenoid	8
2	Turn signal and stop lights (tractor and trailer) with indicators, water temperature gauge, fuel gauge, air cleaner restriction indicator, battery charge indicator, low engine oil pressure indicator, parking brake indicator and sending unit.	8
3	Front R.H. parking light, rear L.H. parking light, license plate light, trailer L.H. parking light, parking light indicator.	8
4	Front L.H. parking light, rear R.H. parking light, trailer R.H. parking light, work light, instrument panel light.	8
5	Low beams.	8
6	High beams and indicator.	8
7	Hazard warning indicator and flasher, power point.	16
8	Thermostarter.	16



**Control Board.**

A. Fuse box - B. Starter switch - C. Lighting switch/Horn button - D. Lower point (unipolar) - E. Turn signal light switch - F. Hazard warning lights button switch and indicator - G. Thermostarter button switch.

# ELECTRICAL SYSTEM: Wiring Diagram

**WIRING DIAGRAM  
TRACTOR**

1. Headlamps, asymmetric high/low beams
2. Battery
3. Alternator
4. Low engine oil pressure sending unit
5. Horn
6. Dry air cleaner restriction sending unit (optional)
7. Starter
8. Hazard warning and turn signal electronic flasher.
9. Multi-function instrument cluster:
  - a. Battery charge indicator (red).
  - b. Low engine oil pressure indicator (red).
  - c. Dry air cleaner restriction indicator (red, optional)
  - d. Parking brake indicator (red).
  - e. Spare.
  - f. Parking lights indicator (green).
  - g. High beam indicator (blue).
  - h. Tractor turn signal indicator (green).
  - i. 1st trailer turn signal indicator (green)
  - j. 2nd trailer turn signal indicator (green)
  - m. Water temperature gauge.
  - n. Fuel gauge.
10. Water temperature gauge sending unit.
11. Thermostarter (optional).
12. Starter switch.
13. Turn signal switch.
14. Lighting switch and horn button.
15. Engine stopping solenoid.
16. Parking brake indicator flasher.
17. Hazard warning switch with indicator.
18. Single-conductor power point.
19. Fuse box.
20. Thermostarter control button (optional).
21. Front parking and turn signal lights.
22. Starter inhibitor switch.
23. Parking brake indicator sending unit.
24. Stop light switch.
25. Rear LH parking, turn signal, stop and license plate lights
26. Seven conductor power point.
27. Work light and switch.
28. Fuel gauge sending unit.
29. Rear RH parking, turn signal and stop lights
30. Overvoltage circuit breaker

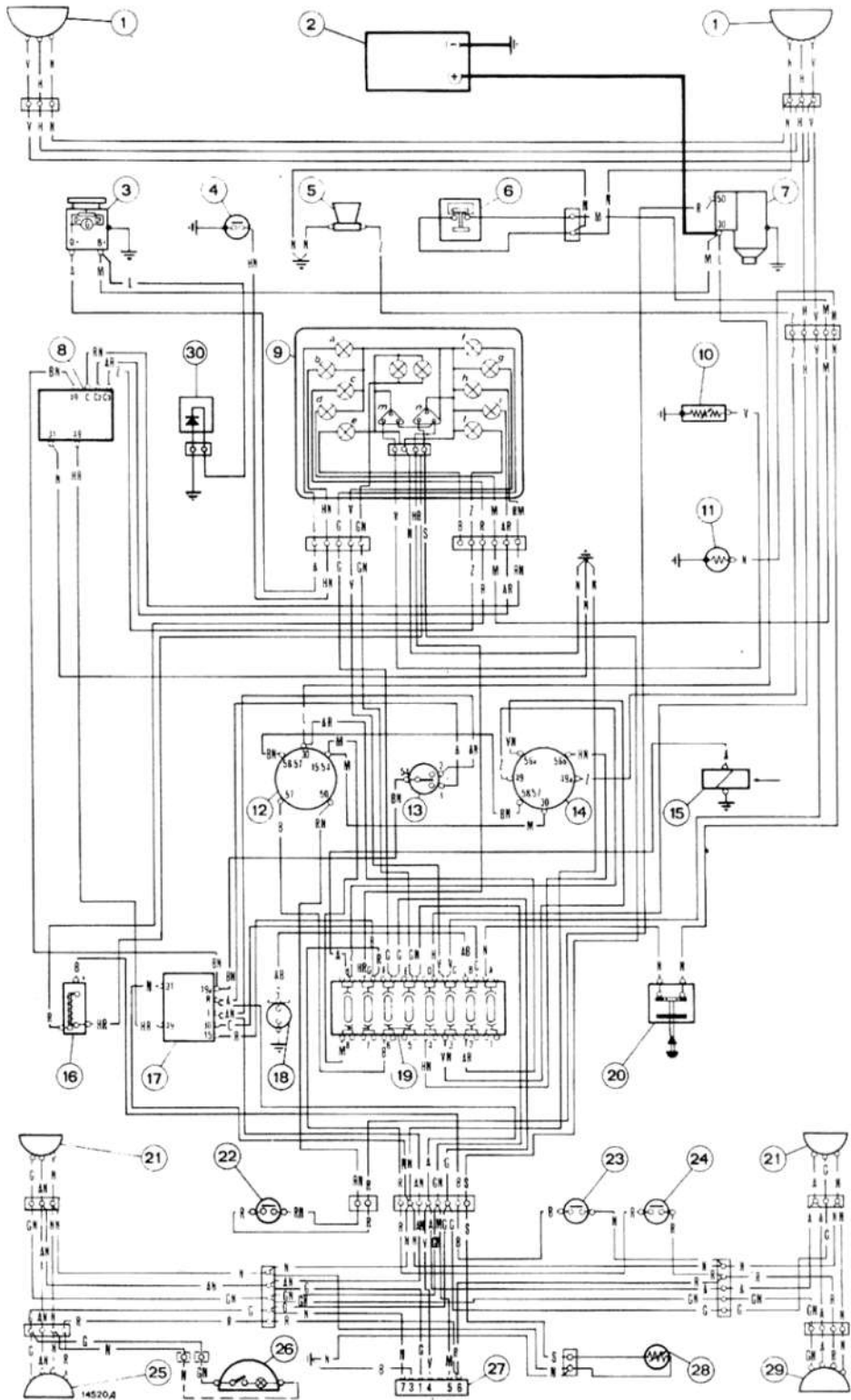

**CABLE COLOUR CODE**

- |                |           |
|----------------|-----------|
| A = Light blue | M = Brown |
| B = White      | N = Black |
| C = Orange     | R = Red   |
| G = Yellow     | S = Pink  |
| H = Grey       | V = Green |
| L = Dark blue  | Z = Mauve |

# NOTES

---

# NOTES